

SECTION C

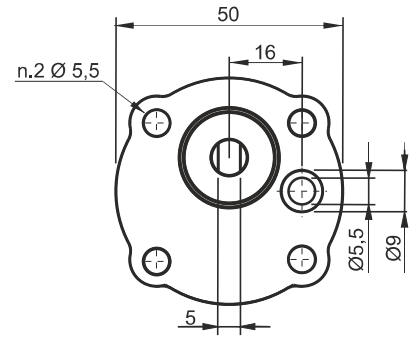

H TYPE HIGH PRESSURE GEAR PUMPS

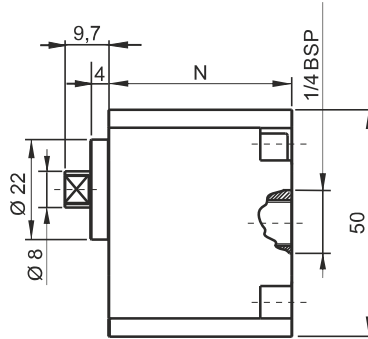

Main features

Oil temperature	-15 + +80 °C
Inlet pressure	0,7 < P < 3,0 bar
Fixing bolts	2 x M5 8.8 steel class tightening torque: 25 Nm
Pressure definition	Peak pressure: cycle 2 s ON Intermittent pressure: cycle 20 s ON Continuous pressure: cycle always ON

Standard rotation direction: clockwise rotation (from shaft side).
Counterclockwise rotation pumps can be mounted on request.
Ask our sales department.

Spare part code

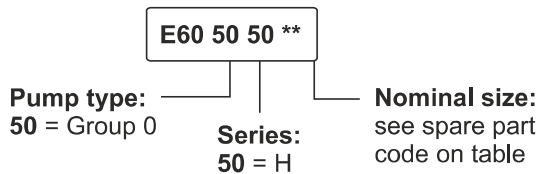

PPM assembly code

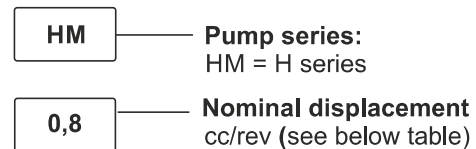

Available range

Nominal displacement [cc/rev]	Peak pressure [bar]	Intermittent pressure [bar]	Continuous pressure [bar]	Max speed [rpm]	N [mm]	Bolts* [mm]	Spare part code	Weight [Kg]
0,1	270	250	230	7000	36,4	5x50	E60505001	0,26
0,2	270	250	230	7000	36,7	5x50	E60505002	0,27
0,4	270	250	230	7000	37,8	5x50	E60505004	0,27
0,6	270	250	230	7000	39,5	5x50	E60505006	0,28
0,8	270	250	230	7000	40,7	5x50	E60505008	0,29
1,2	270	250	230	5000	43,4	5x55	E60505012	0,31
1,5	270	250	230	5000	45,0	5x55	E60505015	0,32

Other gear pumps with different pressure and speed available upon request.

* Washers may be fitted to adapt bolt length