

PROPORTIONAL ELECTRIC DRIVER

- Power supply voltage **12-24VDC**
- Rectified and filtered ripple voltage. **10%**
- Output current **0-1,7A**
- Max current absorption without load **30mA**
- Off-set current. **0-1,0A**
- Medium power absorption. **35W**
- Dither frequency. **50-400Hz**
- Ramp up-down time. **0,1-10 S**
- Current stability on temperature range. **3%**
- Maximum time delay of the ramp independently of the full load current setting. **YES**
- Operating temperature range. **-10/+50°C**
- Protection class. **IP65**
- Weight. **100g**

GENERAL DESCRIPTION

This miniature electronic regulator is embedded into the plug housing with DIN43650 - ISO 4400 connector and allows open loop driving of the solenoid of proportional valves. It is protected against power supply polarity inversion and solenoid short circuit. The minimum and maximum current values are adjusted with two potentiometers, and other two separate potentiometers allow the ramp-up and ramp-down parameter adjustment. A yellow led is lit when the system is powered.

NOTE

The power supply voltage must be in the 12 to 24 V DC range. It is necessary to power the system with rectified and filtered voltage. The use of a 4700 mF 35V electrolytic capacitor is recommended to filter the power voltage supply. The electronic controller can drive valves with coil powered at 12 or 24 Vdc. In order to assure the nominal maximum current value of the coil it is necessary that the voltage supply of the controller exceeds the nominal voltage supply of the coil valve at least of 1,5V.

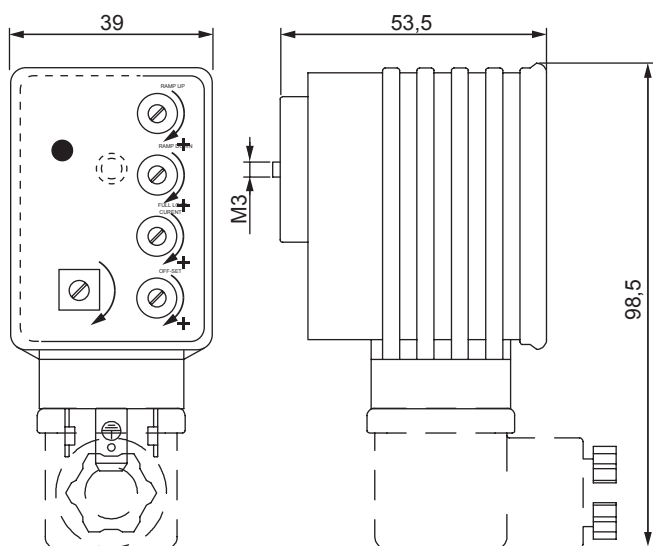

Ordering code

2980010000



PROPORTIONAL ELECTRIC DRIVER

APPLICATIONS

1 - On-Off application mode with switch and ramp setting for acceleration and deceleration uses.

The **GND** and **3** terminals are connected to the two terminals of the switch (normally open). When the switch is closed, the input reference signal is tied to the maximum voltage value and consequently the current of the solenoid reaches the maximum value. When the switch is open the current flowing into the solenoid reaches the minimum value. The **ramp up** and **ramp down** potentiometers allow to adjust, using linear ramp, respectively the time delay between the switching from minimum to maximum current and the delay between the switching from maximum to minimum current. The minimum and maximum current values are adjusted with the offset and full load potentiometers.

2 - Control mode using a voltage generator as input signal.

The external signal control must be connected to terminal 3 and ground (0V) must be connected to terminal 2. The input voltage on the terminal 3 can be regulated from 0 to 10V. The current on the valve coil is proportional to the

input command voltage. Set this signal to the maximum value(10V), then proceed to the adjustment of the full load potentiometer, in order to set the maximum current value on the solenoid.

3 - Control mode with potentiometer.

Pins 1, 2 and 3 of the potentiometer must be connected respectively to the **GND**, **3** and **2** terminals of the controller. To setup the controller, rotate the potentiometer fully clockwise and follow the **“Adjustment instructions”**. A 5KOhm potentiometer is recommended. In any case the potentiometer value must be between 2KOhm and 5KOhm.

4 - Two axes control with joystick.

This control can be done using a joystick with two axes and two EPC-H02 devices. The joystick is connected to a voltage converter; this converters supplies the input reference signals for the two devices. The currents and the ramps of the two devices are independent. By doubling the above said system, it is possible to realize a four axes system.

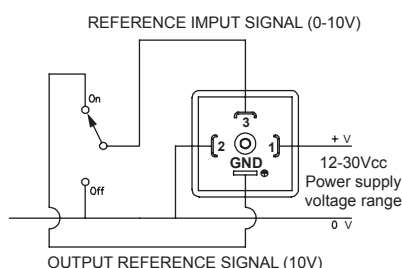

(ON-OFF CONNECTION)

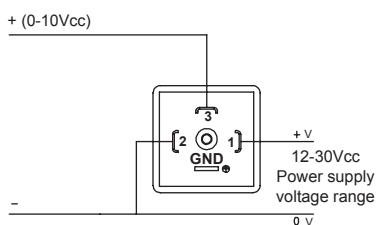

(EXTERNAL CONNECTION)

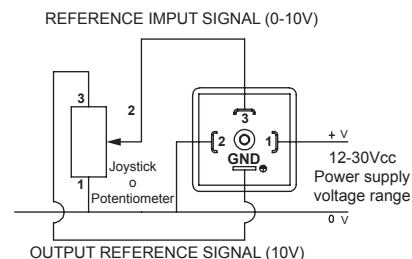

(POTENTIOMETER CONNECTION)

ADJUSTMENT INSTRUCTIONS

After the system is connected, verify that is possible to move the hydraulic cylinder using the potentiometer or the switch. Set the ramp up and ramp down potentiometers to zero, rotating the cursor completely counter clockwise. Set the external potentiometer to zero (or open the external switch) and set the minimum current of the solenoid using the offset potentiometer, rotating it until the hydraulic device begins to move: with this setting, the system will operate without delay. Set the full load potentiometer to zero and rotate the external control potentiometer

completely clockwise (or close the external switch): rotate the full load potentiometer clockwise until the hydraulic cylinder reaches the maximum displacement, then rotate the full load potentiometer back until the hydraulic cylinder comes back slightly. Once the tuning of the start and end positions of the hydraulic cylinder stroke is complete, it is possible to regulate the switching speed between the two extreme positions of the stroke using the ramp up and ramp down potentiometers. This further adjustment doesn't affect the previously tuned settings.