

DETTAGLIO CAVA  
1:1

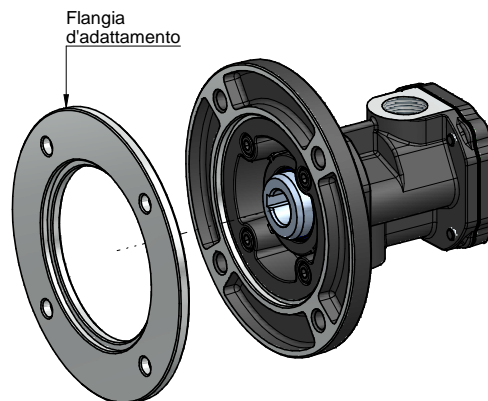

REV.	DATA REV.	DESCRIZIONE REVISIONE / REVISION DESCRIPTION		FIRMA / SIGN.
		CODICE / CODE:	OGGETTO / OBJECT:	TAGLIA / SIZE:
		12733	DIMENSIONALE	GR 40
		COMMENTS / COMMENTS:		TIPO / TYPE:
		Ac24-B5 - BB		SMT-8B
		FOGLIO / SHEET:	SCALA / SCALE:	
		1 di 2	1:2,5	
		DATA / DATE:	DISEGNATORE / DESIGNER:	CONTROLLORE / INSPECTOR:
		06/10/2011	Ivan Bergonti	Ing. Pierpaolo
		MATERIALE / MATERIAL:	MASSA / MASS:	TOLL. GEN.:
			3.5 kg	±0,5
		SMUSSI / BEVELS:	RAGGI / RADIUS:	
		TRATTAMENTO / TREATMENT:		
		PROF. TRATT. / DEPTH TREAT.:	DUREZZA / HARDNESS:	
		RUGOSITA' / ROUGHNESS Ra (μ):		

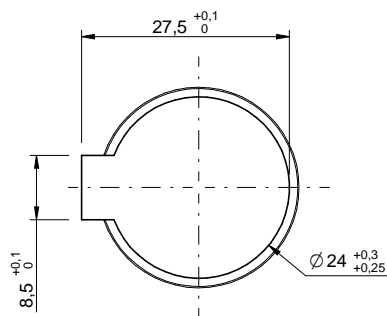

LOC. CONCA DI SETTIMA - GOSSOLENGO - PIACENZA - ITALIA

La ditta si riserva ogni diritto di proprietà del disegno  
The company reserves all rights of ownership of the design