

# Flange SAE filettate GAS BSP threaded SAE flanges

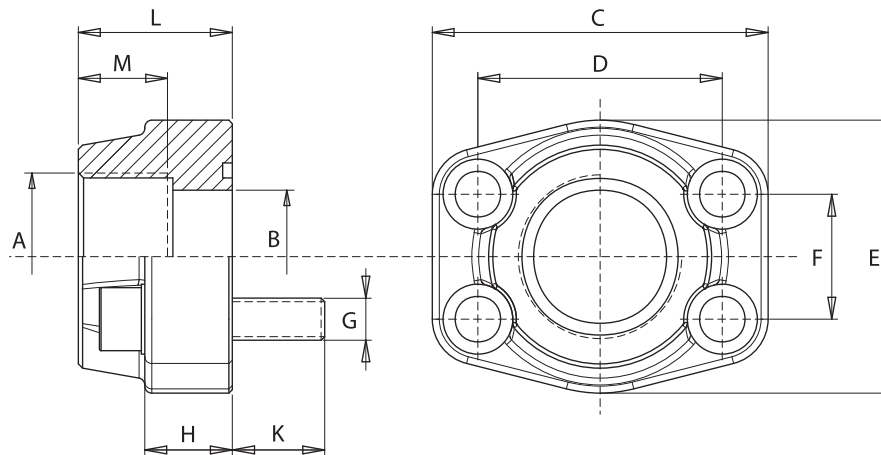

Materiale: Acciaio  
Material: Steel



## 3000 psi

PRESS. MAX bar	TIPO TYPE	A SAE	B	L	H	M	K	C	D	E	F	G		O-Rings
												Viti/Screws Metr.	UNC	
345	F080G038	3/8"	13	36	16	13	14	58	38,10	48	17,48	M8	5/16"	4075
345	F080G012	1/2"	13	36	16	15	14	58	38,10	48	17,48	M8	5/16"	4075
345	F100G034	3/4"	19	36	18	18	16	67	47,63	50	22,23	M10	3/8"	4100
345	F102G100	1"	25	38	18	20	16	72	52,37	54	26,19	M10	3/8"	4131
275	F104G114	1 1/4"	31	41	21	22	18	81	58,72	70	30,18	M10	7/16"	4150
200	F106G112	1 1/2"	38	44	25	24	18	95	69,85	78	35,71	M12	1/2"	4187
200	F108G200	2"	50	45	25	26	18	104	77,77	90	42,88	M12	1/2"	4225
170	F110G212	2 1/2"	63	50	25	30	18	116	88,90	102	50,80	M12	1/2"	4275
135	F112G300	3"	73	50	27	30	25	136	106,38	125	61,93	M16	5/8"	4337
35	F114G312	3 1/2"	89	50	27	30	25	153	120,65	137	69,85	M16	5/8"	4387
35	F116G400	4"	99	50	27	30	25	163	130,18	147	77,77	M16	5/8"	4437
35	F118G500	5"	120	50	28	30	25	185	152,40	181	92,08	M16	5/8"	4537

## 6000 psi

PRESS. MAX bar	TIPO TYPE	A SAE	B	L	H	M	K	C	D	E	F	G		O-Rings
												Viti/Screws Metr.	UNC	
420	F401G038	3/8"	13	36	16	13	14	58	40,49	48	18,24	M8	5/16"	4075
420	F401G012	1/2"	13	36	16	15	14	58	40,49	48	18,24	M8	5/16"	4075
420	F402G034	3/4"	19	36	19	18	16	72	50,80	54	23,80	M10	3/8"	4100
420	F403G100	1"	25	44	24	20	19	81	57,15	70	27,76	M12	7/16"	4131
420	F404G114	1 1/4"	31	44	27	22	22	95	66,68	78	31,75	M14	1/2"	4150
420	F405G112	1 1/2"	38	51	30	24	24	107	79,38	90	36,50	M16	5/8"	4187
420	F406G200	2"	50	70	37	33	32	136	96,82	117	44,45	M20	3/4"	4225
420	F408G212	2 1/2"	63	75	45	35	40	167	123,80	151	58,70	M24	-	4275
420	F410G300	3"	73	90	55	40	55	209	152,40	179	71,40	M30	-	4337

## Esempio codice di ordinazione - Ordering example

Flangia  
Flange

F404 G114 -

Su richiesta: - On request:

**M** Viti metriche, rondelle, O-Rings  
Metrical screws, washers, O-Rings

**U** Viti UNC, rondelle, O-Rings  
UNC screws, washers, O-Rings  
(brunite - burnished)