

Clogging Indicators
DG 060 · DG 061 · DG 062 · DG 063 · DG 064

for Pressure and High Pressure Filters · Operating pressure up to 600 bar · Response/switching pressure up to 5,0 bar



 Clogging indicators
 DG 062 and DG 064

Description
Application

Monitoring the contamination of pressure and high pressure filters.

General

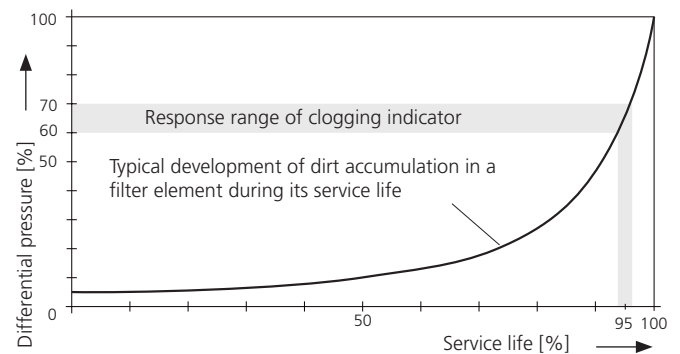
Filter elements installed in hydraulic filters remove dirt from a hydraulic system and therefore become contaminated themselves. Free pores or spaces in the filter material are obstructed by dirt particles, which causes a continuous increase in the pressure loss.

 The dirt load collected in a filter element gradually increases during service, which also leads to a higher pressure drop. The resulting differential pressure Δp is monitored by a clogging indicator. Once a preset value is reached, an electrical and/or optical signal is generated.

The following must be observed in this context:

The pressure drop caused by the filter element increases depending on the flow rate, the dirt load, and the viscosity of the pressure fluid.

Therefore, a filter element is not regarded contaminated before the clogging indicator responds at operating temperature of the hydraulic system, causing a continuous signal.

Consequences of an overdue filter element change
For filters equipped with a bypass valve:

The more dirt has collected in the filter element, the more frequently the bypass valve opens and part of the hydraulic fluid remains unfiltered. The high pressure loss causes unnecessary power consumption.

For filters without a bypass valve:

The increasing pressure loss across the filter element, which reduces the efficiency of the hydraulic system, eventually causes malfunctions to occur or a pressure relief valve to respond.

Design and principle of operation

Within the clogging indicator, the differential pressure $\Delta p = p_1 - p_2$ (pressure upstream of the element minus pressure downstream of the element) caused by the filter element acts on a magnetic piston against the force of a spring. In optical (mechanical) clogging indicators, the increasing differential pressure causes the piston to approach a second magnet with reversed polarity which in turn causes the indicator to change from green to red. In electrical clogging indicators, the magnetic piston triggers a reed switch.

Special design features

Piston seal:

The piston actuated by the differential pressure is equipped with a leak-free O-ring seal. As a result, the total flow passes the filter element.

Proximity position sensing:

Piston movement is detected by sensing a magnetic field, i.e. without mechanical contact. For this reason, ARGO-HYTOS clogging indicators are absolutely leakfree.

Characteristics

Operating pressure

0 ... 420 bar, min. 10^7 pressure cycles
Nominal pressure according to DIN 24550

0 ... 600 bar, min. 10^4 pressure cycles
Quasi-static operating pressure

Connection

Profiled bore, see section Dimensions

Hydraulic fluids

Mineral oil and biodegradable fluids
(HEES and HETG, see info-sheet 00.20)

Temperature range of fluids

-30 °C ... +100 °C (short term 125 °C)

Ambient temperature range

-30 °C ... +80 °C

Materials

Housing:	Stainless steel
Piston:	Polyamide
Socket:	Polyamide
Display piece DG 062 / DG 064	Polyamide
Seals:	NBR (FPM on request)

Operating voltage

max. 48 V DC

Electrical service life

10^7 switching cycles

Electrical protection

IP 67 (in connected condition) for DG 060, DG 061, DG 062

Exception: IP 65 (with mounted and secured socket)
for versions with connector socket according to DIN EN 175301-803.

Mounting position

No limitation

Wiring suggestions

Current limiter for DC and AC voltage:

If light bulbs or other loads are connected over long distances (conductor capacity!), a protective resistor should be connected in series in order to limit the current. The same applies when capacitance loads are connected.

Spark suppression in DC applications:

The contacts of Reed switches open extremely fast, causing voltage peaks to be induced when switching off inductive loads, such as relays, lifting magnets, or solenoid valves. The resulting self-induction currents are short-circuited by connecting a diode in parallel to the inductive load.

Spark suppression in AC applications:

In AC applications, a diode connected in parallel to the load is not sufficient. RC elements should be used here, connected in parallel to the Reed switch. Please contact our design engineers for advice in order to select a suitable RC element.

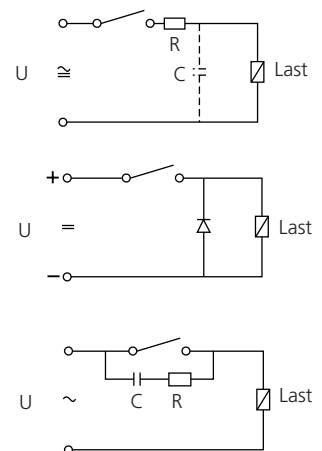

DG 063 - Optical differential pressure indicator with automatic reset

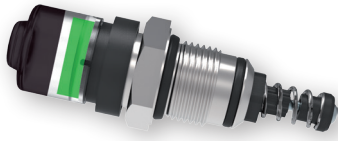

Function:

When the preset differential pressure is reached, the optical indicator changes from green to red. If the pressure differential returns to a value below the preset limit, the indicator changes back to green, i.e. no manual reset of the indicator is required.

DG 064 - Optical differential pressure indicator with manual reset



Function:

When the preset differential pressure is reached, a red pin retracts from the hole of the indication. If the pressure differential returns to a value below the preset limit, the pin does not disappear automatically. Due to the fitted resting function, a manual reset of the indicator is required.

DG 060 - Electrical differential pressure switch (make)

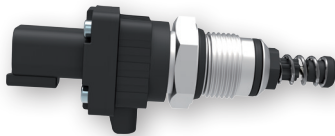

Function:

The built-in Reed switch closes when the preset differential pressure is reached.

DG 061 - Electrical differential pressure switch (break)

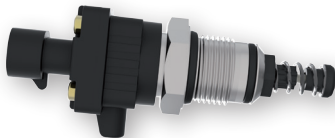

Function:

The built-in Reed switch opens when the preset differential pressure is reached.

DG 062 - Electrical differential pressure switch (change-over)

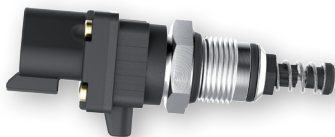

Function:

When the preset differential pressure is reached, the built-in Reed switch changes over. The change-over (CO) switch makes it possible to indicate a broken wire by means of a suitable electronic circuit, as compared to a make contact (normally open NO) switch.

Option:

For versions with connector plug according to DIN EN 175301-803 and symbol 6, a transparent socket with 2 built-in LEDs is available. This socket makes it possible to have an additional optical indication of the filter contamination. When the operating voltage is switched on, a green LED lights up. When the switching pressure is reached, a yellow LED lights up in addition.

Selection Chart

Part No.	Optical indicator	Electrical indicator	Response/switching pressure	Type of contact	Switching voltage U	Switching current I	Switching power P	Symbol	Weight	Remarks
1	2	3	4	5	V AC/DC	A AC/DC	V AW AC/DC	9	kg	11
DG 063-02	•	-	2,0	-	-	-	-	1	0,09	automatic reset
DG 063-05	•	-	5,0	-	-	-	-	1	0,09	automatic reset
DG 064-02	•	-	2,0	-	-	-	-	2	0,09	manual reset
DG 064-05	•	-	5,0	-	-	-	-	2	0,09	manual reset
DG 060-31	-	•	2,0	make	48/48	0,5/0,5	10/10	3	0,09	AMP Superseal-2P*
DG 060-21	-	•	2,0	make	48/48	0,5/0,5	10/10	3	0,09	Deutsch DT04-2P*
DG 060-30	-	•	5,0	make	48/48	0,5/0,5	10/10	3	0,09	AMP Superseal-2P*
DG 060-20	-	•	5,0	make	48/48	0,5/0,5	10/10	3	0,09	Deutsch DT04-2P*
DG 061-31	-	•	2,0	break	48/48	0,5/0,5	10/10	4	0,09	AMP Superseal-2P*
DG 061-21	-	•	2,0	break	48/48	0,5/0,5	10/10	4	0,09	Deutsch DT04-2P*
DG 061-30	-	•	5,0	break	48/48	0,5/0,5	10/10	4	0,09	AMP Superseal-2P*
DG 061-20	-	•	5,0	break	48/48	0,5/0,5	10/10	4	0,09	Deutsch DT04-2P*
DG 062-04	-	•	2,0	change-over	48/48	0,5/0,5	10/10	5	0,09	DIN EN 175301-803*
DG 062-05	-	•	2,0	change-over	48/48	0,5/0,5	10/10	6	0,09	DIN EN 175301-803*
DG 062-01	-	•	5,0	change-over	48/48	0,5/0,5	10/10	5	0,09	DIN EN 175301-803*
DG 062-02	-	•	5,0	change-over	48/48	0,5/0,5	10/10	6	0,09	DIN EN 175301-803*
DG 062-31	-	•	2,0	change-over	48/48	0,5/0,5	10/10	7	0,09	AMP Superseal-3P*
DG 062-21	-	•	2,0	change-over	48/48	0,5/0,5	10/10	8	0,09	Deutsch DT04-3P*
DG 062-41	-	•	2,0	change-over	48/48	0,5/0,5	10/10	9	0,09	M12 x 1-4P*
DG 062-30	-	•	5,0	change-over	48/48	0,5/0,5	10/10	7	0,09	AMP Superseal-3P*
DG 062-20	-	•	5,0	change-over	48/48	0,5/0,5	10/10	8	0,09	Deutsch DT04-3P*
DG 062-40	-	•	5,0	change-over	48/48	0,5/0,5	10/10	9	0,09	M12 x 1-4P*

*Design of the connector plug - connector socket not included in the scope of delivery.

Remarks:

- › The response/switching pressure of the clogging indicator must be lower than the cracking pressure of the bypass valve of the filter.
- › The clogging indicators listed in this chart are standard units. Other designs available on request.
- › Reed switches are sensitive of excessively strong currents. Even a short-term overload causes an increased contact resistance or failure of the switch. By taking the precautions described in paragraph wiring suggestions, premature failure of Reed switches due to overload is avoided.

Dimensions

DT04 -2P/-3P

AMP -2P/-3P

M12 x 1-4P

DG 063 (autom. RS)

DG 064 (man. RS)

DIN EN 175301-803

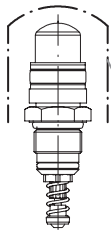
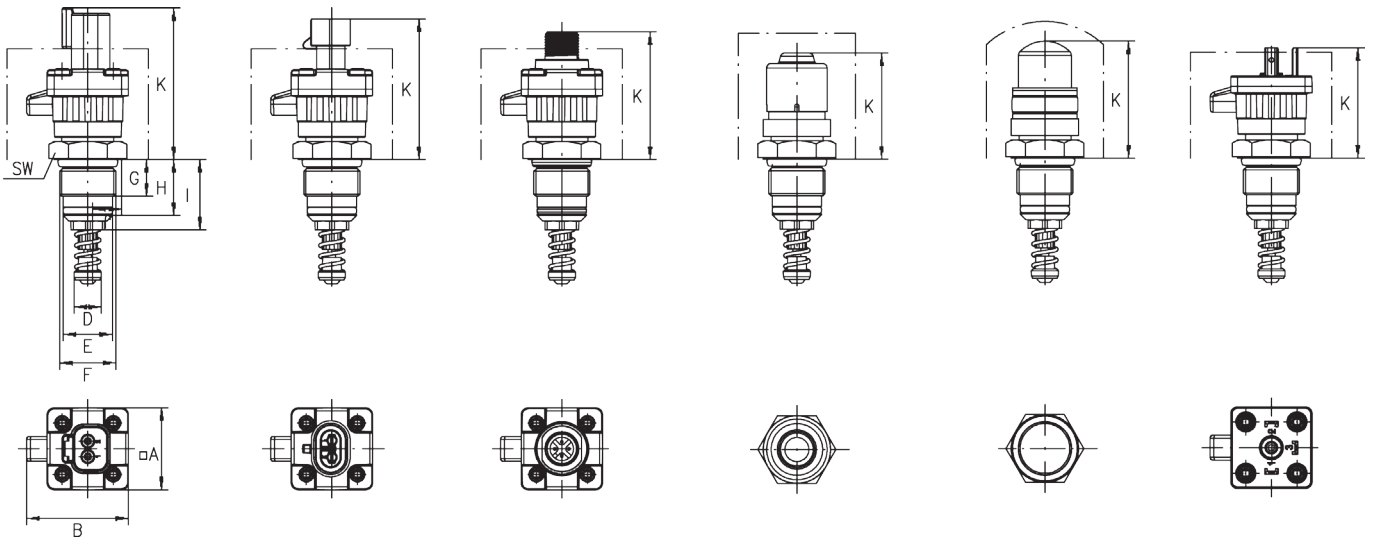

Minimum distance from ferromagnetic parts: 7mm

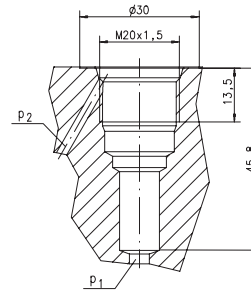

All for processing necessary measurements and tolerances are available on request.

Measurements

Type	A	B	D	E	F	G	H	I	K	AF
DT04 -2P/-3P	□ 29	36,5	9,7	17,5	M20 x 1,5	13	20	25	55	24
AMP -2P/-3P	□ 29	36,5	9,7	17,5	M20 x 1,5	13	20	25	50	24
M12 x 1-4P	□ 29	36,5	9,7	17,5	M20 x 1,5	13	20	25	46	24
DG 063	-	-	9,7	17,5	M20 x 1,5	13	20	25	37,5	24
DG 064	-	-	9,7	17,5	M20 x 1,5	13	20	25	41,5	24
DIN EN 175301-803	□ 29	36,5	9,7	17,5	M20 x 1,5	13	20	25	39	24

Symbols

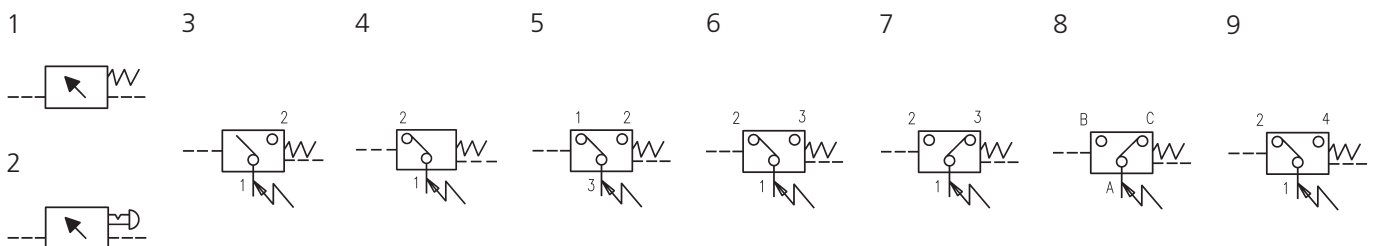

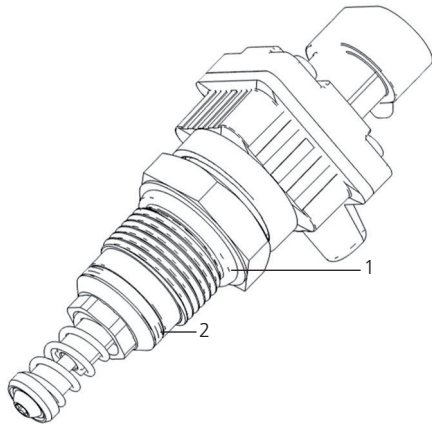

Pos.	Designation	Part No.
1	O-ring 17,3 x 2,2	N007.0172-4
2	O-ring 14 x 1,78	N007.0142

The functions of the complete filters as well as the outstanding features of the filter elements assured by ARGO-HYTOS can only be guaranteed if original ARGO-HYTOS spare parts are used.

Quality Assurance

Quality management according to DIN EN ISO 9001

Various quality controls during the production process guarantee the leakfree function and solidity of our products.

Illustrations may sometimes differ from the original. ARGO-HYTOS is not responsible for any unintentional mistake in this specification sheet.