

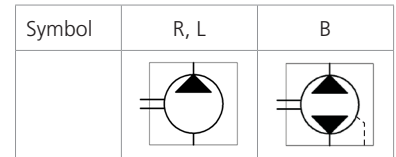

Technical Features

- › Nominal pressure 280 bar, peak pressure 310 bar
- › High quality aluminum alloys pump with
- › Axial play compensation
- › Low noise level in whole operating range
- › High operational reliability and long service life
- › High volumetric efficiency up to 98%
- › International standards flanges as per SAE, ISO, DIN, GHOST



Technical Data

Nominal Size Parameters	Symbol	Unit	Displacement														
			0,8	1,2	1,6	2,1	2,5	3,3	3,6	4,4	4,8	5,8	6,2	7,0	7,9	10,0	11,8
Actual displacement	V <sub>g</sub>	[cm <sup>3</sup> ]	0,855	1,257	1,686	2,086	2,514	3,316	3,611	4,386	4,787	5,804	6,205	7,007	7,890	10,003	11,795
		[in <sup>3</sup> ]	0.052	0.077	0.103	0.127	0.153	0.202	0.220	0.268	0.292	0.354	0.379	0.428	0.481	0.610	0.720
Rotation speed	nominal	n <sub>n</sub>	1500														
	minimum	n <sub>min</sub>	800			600			500								
	maximum	n <sub>max</sub>	5000			4500			4000			3800		3500		3000	
Pressure at inlet*	minimum	p <sub>1min</sub>	-0,3 (-4.4 PSI)														
	maximum	p <sub>1max</sub>	0,5 (7.3 PSI)														
Pressure at outlet**	max. continuous	p <sub>2n</sub>	280					260	250	230	200	180	170	160	100		
		[PSI]	4061					3771	3625	3336	2901	2611	2466	2321	1450		
	maximum	p <sub>2max</sub>	300					280	270	250	220	200	190	180	150		
		[PSI]	4351					4061	3916	3625	3191	2901	2756	2611	2176		
peak	p <sub>3</sub>	310					290	280	260	230	210	200	190	160			
	[PSI]	4496					4206	4061	3771	3336	3046	2901	2756	2321			
Nominal flow rate (min.) at n <sub>n</sub> and p <sub>2n</sub>	Q <sub>n</sub>	[l min <sup>-1</sup> ]	1,07	1,60	2,13	2,71	3,35	4,54	4,98	6,06	6,61	8,00	8,56	9,65	10,90	13,90	16,30
		[GPM]	0.28	0.42	0.56	0.72	0.88	1.20	1.32	1.60	1.75	2.11	2.26	2.55	2.88	3.67	4.31
Maximum flow rate at n <sub>max</sub> and p <sub>2max</sub>	Q <sub>max</sub>	[l min <sup>-1</sup> ]	3,92	5,88	7,06	9,26	9,80	12,94	14,11	17,25	17,88	21,60	21,27	20,58	23,23	17,64	20,82
		[GPM]	1.04	1.55	1.87	2.45	2.59	3.42	3.73	4.56	4.72	5.71	5.62	5.44	6.14	4.66	5.50
Nominal input power (max.) at n <sub>n</sub> and p <sub>2n</sub>	P <sub>n</sub>	[kW]	0,7	1,04	1,39	1,72	2,07	2,97	3,35	3,23	3,24	3,41	3,29	3,50	3,71	2,94	3,47
Maximum input power at n <sub>max</sub> and p <sub>2max</sub>	P <sub>max</sub>	[kW]	2,51	3,70	4,96	5,52	6,65	7,80	7,93	9,29	8,29	9,51	8,52	7,83	8,35	5,30	6,06
Weight	m	[kg]	0,82	0,84	0,85	0,87	0,89	0,92	0,93	0,96	0,98	1,02	1,04	1,08	1,10	1,20	1,25
		[lbs]	1.81	1.85	1.87	1.92	1.96	2.03	2.05	2.12	2.16	2.25	2.29	2.38	2.43	2.65	2.76

- 1) \*Inlet pressure in the reversible design can be up to **p<sub>1</sub> = p<sub>2n</sub> -70 bar max.** External drainage must be used in case of the reversible design.
- 2) \*\*Outlet pressure in the reversible design is 10% lower than shown in the table (depending on operating conditions).
- 3) **p<sub>2n</sub>** maximum continuous pressure - maximum working pressure, at which the pump can be operated without time limitation.
- 4) **p<sub>2max</sub>** maximum pressure - maximum pressure permissible for a short time, max. 20 s.
- 5) **p<sub>3</sub>** peak pressure - short-time pressure (fractions of a second) arising in case of a sudden change of the operating mode; any excess of this pressure during operation is impermissible.

Gear Pump / Size		GP1 - 0,8 ...11,8 ccm
Volumetric efficiency	%	92 ÷ 98
Mechanical efficiency	%	85
Fluid temperature range (NBR)	°C (°F)	-20...80 (-4...176)
Fluid temperature range (FPM)	°C (°F)	-20...120 (-4...248)
Viscosity range	mm <sup>2</sup> /s (SUS)	20 ...80 (97 ...390), 1200 (5849) for cold start
Hydraulic fluid		Hydraulic oils of power classes (HL, HLP) to DIN 51524
Max. degree of fluid contamination for p <sub>2</sub> ≤ 200 bar		Class 21/18/15 acc. to ISO 4406
Max. degree of fluid contamination for p <sub>2</sub> ≥ 200 bar		Class 20/17/14 acc. to ISO 4406



**0,8 ccm**

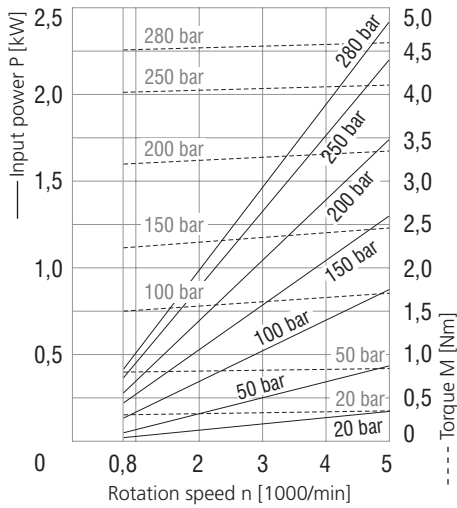

**1,6 ccm**

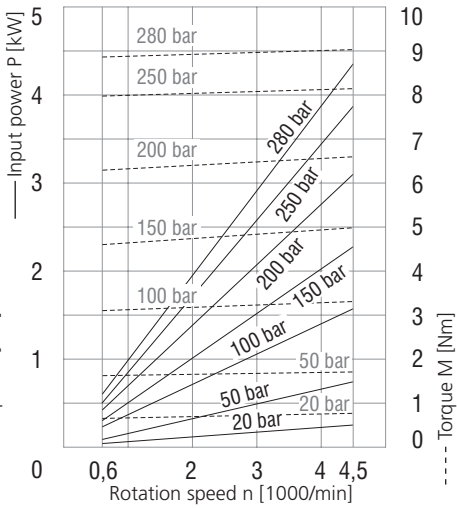

**2,5 ccm**

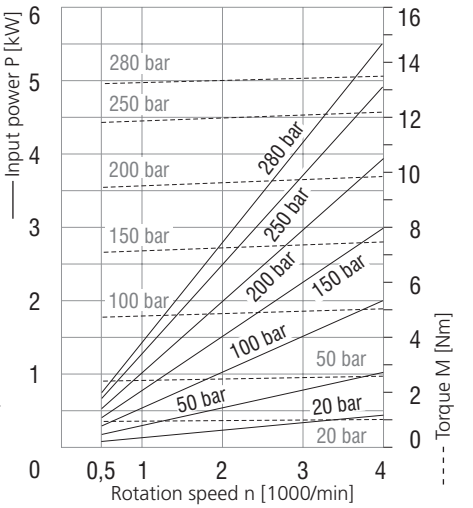

**3,6 ccm**

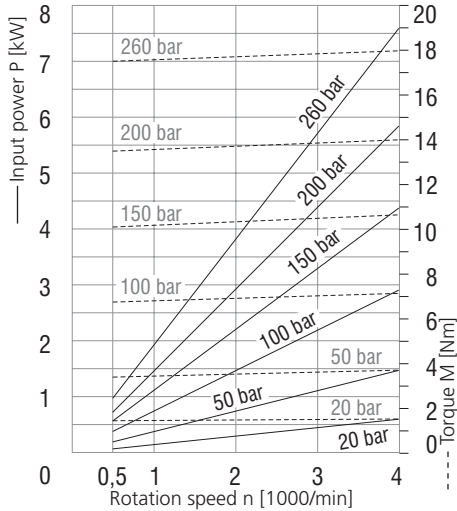

**4,8 ccm**

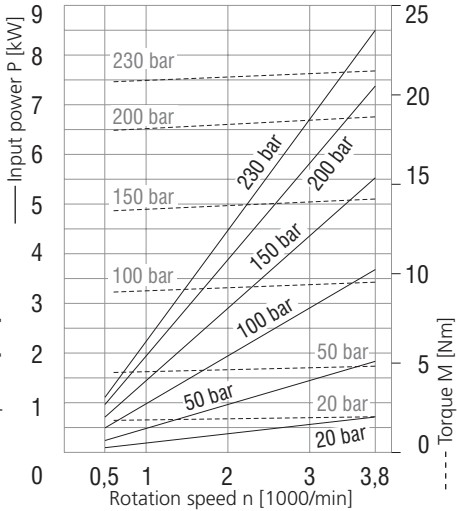

**6,2 ccm**

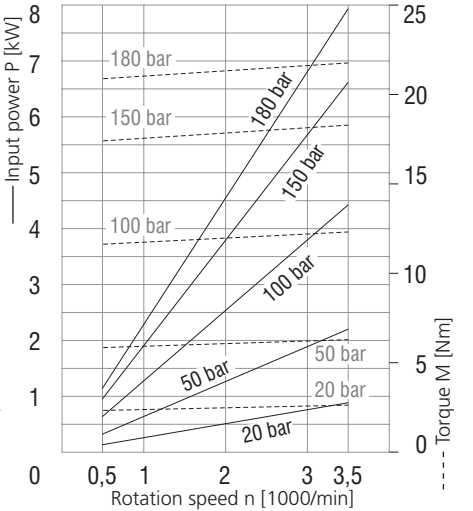

**7,9 ccm**

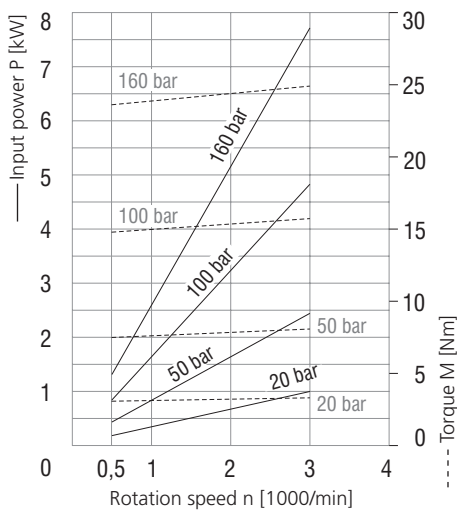

**11,8 ccm**

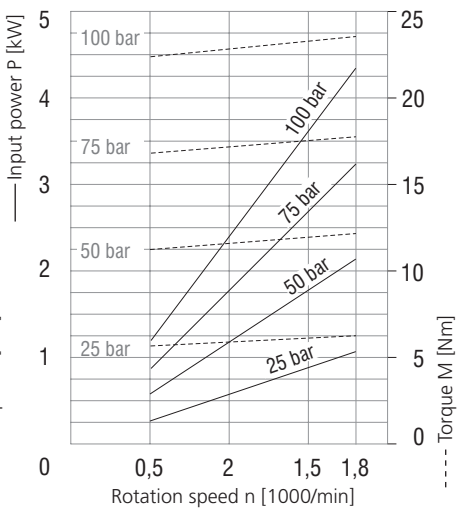

## Ordering Code - Multiple Version

<b>GP1</b>	<b>- 3,3 / 3,3</b>	<b>- R</b>	<b>- SA</b>	<b>DA</b>	<b>- S</b>	<b>GBGB / BAGA</b>	<b>- V</b>	<b>004</b>	
<b>Gear pump serie 1</b>	Front pump (shaft side) Rear pump					Front pump (shaft side) - inlet, outlet port Rear pump - inlet, outlet port. (Two inlet ports are described here as sample)		No designation 004	Shaft seal standard without shaft seal
<b>Displacement</b>									Seals NBR PM (Viton)
<b>Direction of rotation</b>									Inlet / Outlet ports
Counter clockwise Clockwise Bi-directional		L R B	RB SA AC AD AE AF	CB CC DA KC KD VB VC	S C				Ports orientation Use bling plug for not used suction ports
<b>Flange design</b>									Shaft Type

## Ports orientation

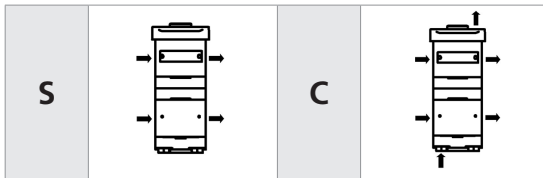

## Flange design in millimeters (inches)

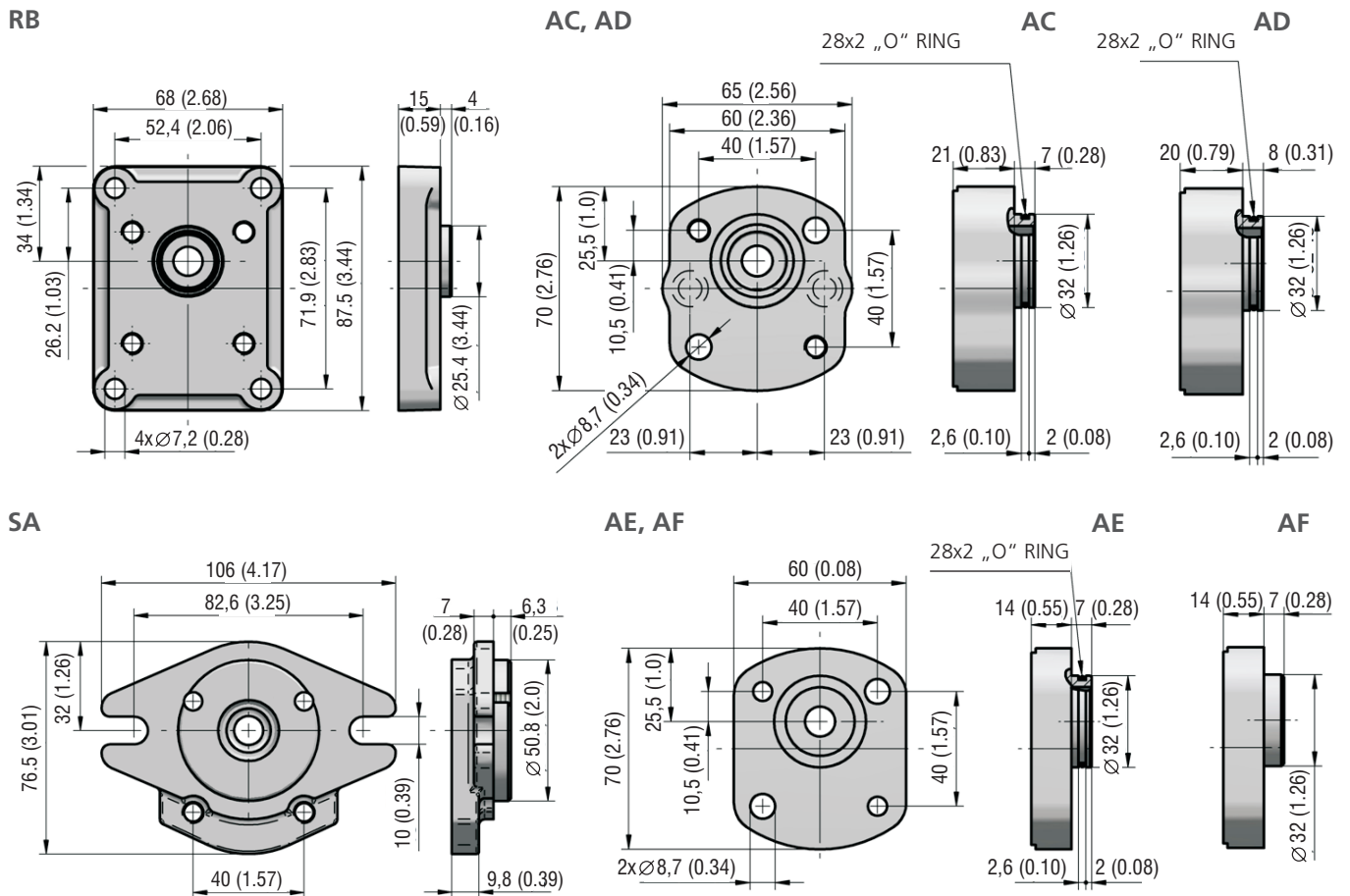

**Shaft design** in millimeters (inches)

**VB**

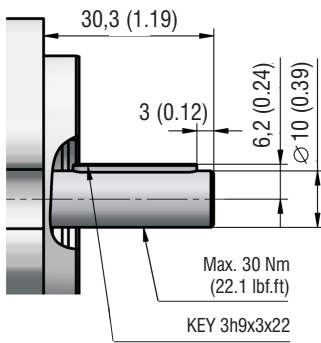

**VC**

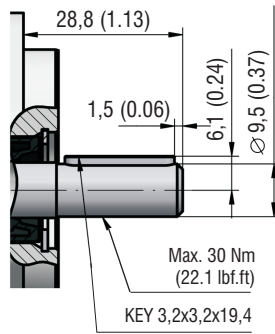

**DA**

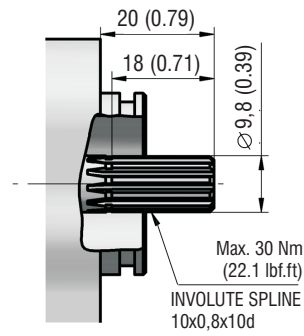

**CB, CC**

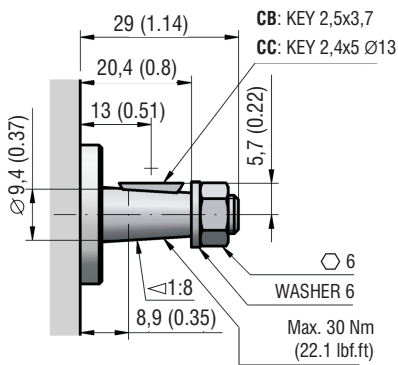

**KC**

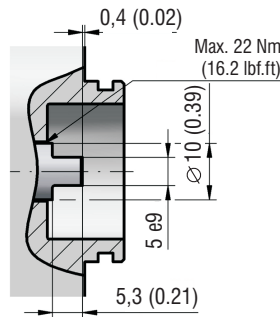

**KD**

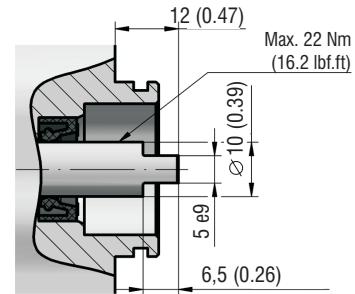

**Ports design** in millimeters (inches)

**Metric thread according to ISO 6149**

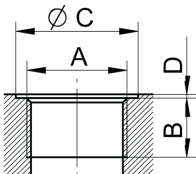

Displacement cm <sup>3</sup> (in <sup>3</sup> )	Inlet Code	Dimension				Outlet Code	Displacement cm <sup>3</sup> (in <sup>3</sup> )
		A	B	C	D		
0,18-0,5 (0.01-0.03)	xx	M12x1,5	12 (0.47)	20 (0.79)	1 (0.04)	MB	ALL
	MC	M14x1,5	13 (0.51)	26 (1.02)		MC	ALL
	MD	M16x1,5	14 (0.55)	22 (0.89)		MD	ALL
ALL	ME	M18x1,5	13 (0.51)	30 (1.18)		ME	ALL
ALL	MF	M20x1,5	14 (0.55)	26 (1.02)		xx	
3,3-11,8 (0.20-0.72)	MH	M22x1,5	13 (0.51)	35 (1.38)		xx	
DRAIN	MA	M10x1	8 (0.31)	15 (0.59)		xx	

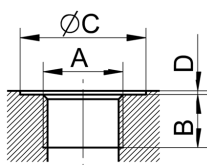
**BSPP pipe thread according to 228-1**

Displacement cm <sup>3</sup> (in <sup>3</sup> )	Inlet Code	Dimension				Outlet Code
		A	B	C	D	
ALL	xx	G1/4	13 (0.51)	26 (1.02)	1 (0.04)	GA
	GB	G3/8		24 (0.94)		GB
	GC	G1/2		34 (1.34)		GC

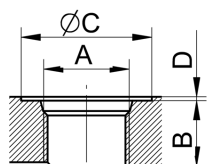
**UNF thread according to SAE**

Displacement cm <sup>3</sup> (in <sup>3</sup> )	Inlet Code	Dimension				Outlet Code
		A	B	C	D	
ALL	xx	9/16-18UNF	13 (0.51)	24,6 (0.97)	1 (0.04)	UB
	UC	3/4-16UNF				UC
	UD	7/8-14UNF		16 (0.63)		34 (1.34)

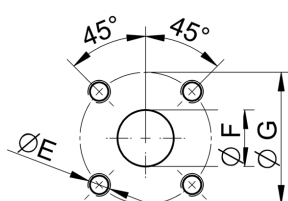
**Flanged fittings according to DIN 8901/8902**

Displacement cm <sup>3</sup> (in <sup>3</sup> )	Inlet Code	Dimension			Outlet Code
		E	F	G	
ALL	HA	M5, depth 12	8 (0.31)	26 (1.02)	HA
	HB		10 (0.39)		HB
	HC	M6 depth 12	8 (0.31)	30 (1.18)	HC
	HD		12 (0.47)		HD

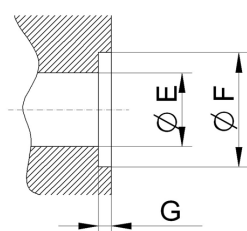
**Inlet / Outlet in flange**

Code	Dimension		
	E	F	G
PA	8 (0.31)	12,4 (0.49)	1,4 (0.06)

GP1-\*R(L)-SAVC-SUDUD-N

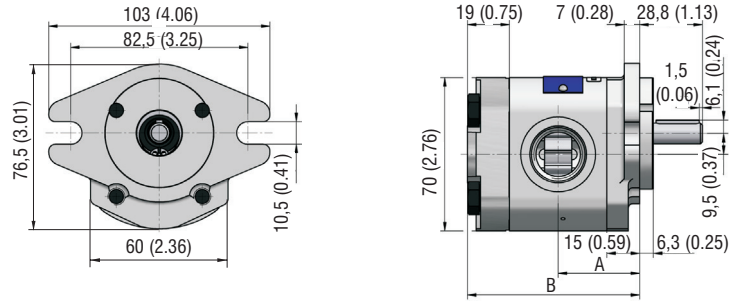

Displacement [cm <sup>3</sup> (in <sup>3</sup> )/rev]	A	B	Displacement [cm <sup>3</sup> (in <sup>3</sup> )/rev]	A	B
0,8 (0.05)	32,6 (1.28)	69,3 (2.73)	3,6 (0.22)	37,8 (1.49)	79,6 (3.13)
1,2 (0.07)	33,4 (1.31)	70,8 (2.79)	4,4 (0.27)	39,2 (1.54)	82,5 (3.25)
1,6 (0.10)	34,1 (1.34)	72,3 (2.85)	4,8 (0.29)	40,0 (1.57)	84,0 (3.31)
2,1 (0.13)	34,9 (1.37)	73,9 (2.91)	5,8 (0.35)	41,9 (1.65)	87,8 (3.46)
2,5 (0.15)	35,7 (1.41)	75,5 (2.97)	6,2 (0.38)	42,6 (1.68)	89,3 (3.53)
3,3 (0.20)	37,2 (1.46)	78,5 (3.09)	7,9 (0.48)	45,8 (1.80)	95,6 (3.76)

GP1-\*R-RBCC-SHDUD-N

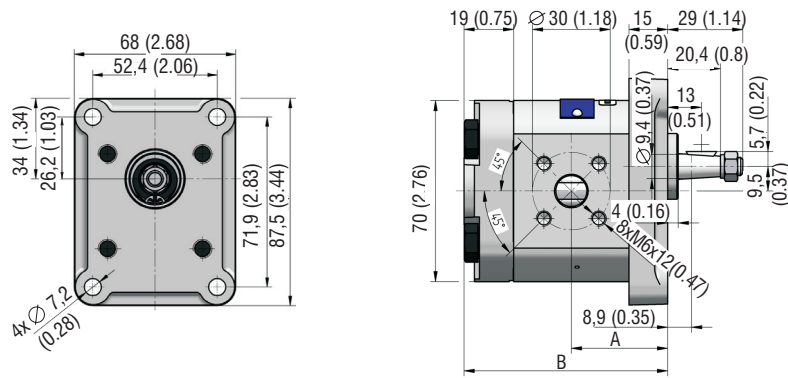

Displacement [cm <sup>3</sup> (in <sup>3</sup> )/rev]	A	B	Displacement [cm <sup>3</sup> (in <sup>3</sup> )/rev]	A	B
0,8 (0.05)	32,6 (1.28)	69,3 (2.73)	3,6 (0.22)	37,8 (1.49)	79,6 (3.13)
1,2 (0.07)	33,4 (1.31)	70,8 (2.79)	4,4 (0.27)	39,2 (1.54)	82,5 (3.25)
1,6 (0.10)	34,1 (1.34)	72,3 (2.85)	4,8 (0.29)	40,0 (1.57)	84,0 (3.31)
2,1 (0.13)	34,9 (1.37)	73,9 (2.91)	5,8 (0.35)	41,9 (1.65)	87,8 (3.46)
2,5 (0.15)	35,7 (1.41)	75,5 (2.97)	6,2 (0.38)	42,6 (1.68)	89,3 (3.53)
3,3 (0.20)	37,2 (1.46)	78,5 (3.09)	7,9 (0.48)	45,8 (1.80)	95,6 (3.76)

GP1-\*L-ADKD-AGBPA-N

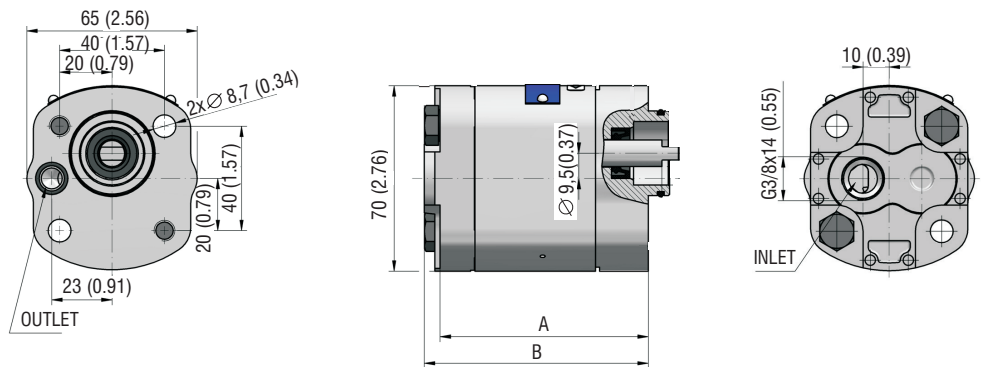

Displacement [cm <sup>3</sup> (in <sup>3</sup> )/rev]	A	B	Displacement [cm <sup>3</sup> (in <sup>3</sup> )/rev]	A	B
0,8 (0.05)	68,3 (2.69)	74,3 (2.93)	3,6 (0.22)	78,6 (3.09)	84,6 (3.33)
1,2 (0.07)	69,8 (2.75)	75,8 (2.98)	4,4 (0.27)	81,5 (3.21)	81,5 (3.21)
1,6 (0.10)	71,3 (2.81)	77,3 (3.04)	4,8 (0.29)	83,0 (3.27)	89,0 (3.50)
2,1 (0.13)	72,9 (2.87)	78,9 (3.11)	5,8 (0.35)	86,8 (3.42)	92,8 (3.65)
2,5 (0.15)	74,5 (2.93)	80,5 (3.17)	6,2 (0.38)	88,3 (3.48)	94,3 (3.71)
3,3 (0.20)	77,5 (3.05)	83,5 (3.29)	7,9 (0.48)	94,6 (3.72)	100,6 (3.96)

**GP1 Pumps - basic design** in millimeters (inches)

**GP1-\*/\*L-ACKA-CGBPA/GBGBGB-N**

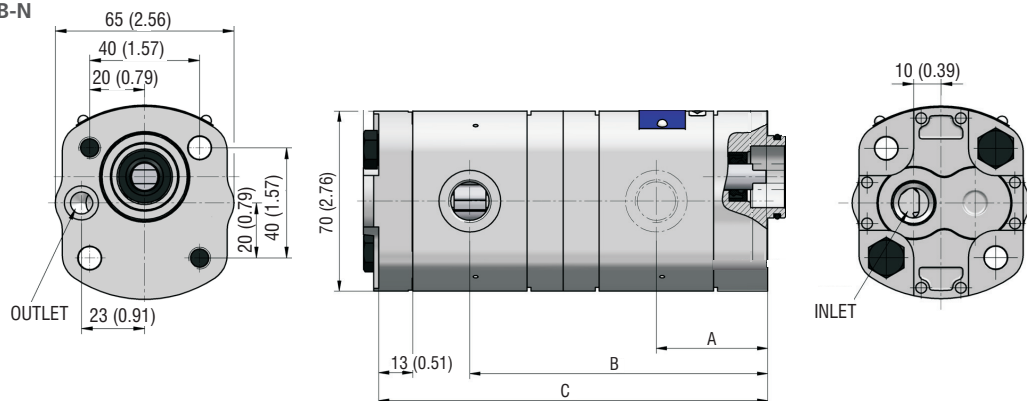

Displacement [cm <sup>3</sup> (in <sup>3</sup> )/rev]	A	B	C	Displacement [cm <sup>3</sup> (in <sup>3</sup> )/rev]	A	B	C
1,6 / 4,8 (0.10 / 0.29)	40,1 (1.58)	112,3 (4.42)	150,3 (5.92)	3,3 / 4,4 (0.20 / 0.27)	43,2 (1.70)	117,7 (4.63)	155,0 (6.10)
1,6 / 5,8 (0.10 / 0.35)	40,1 (1.58)	114,2 (4.50)	154,1 (6.07)	6,2 / 1,6 (0.38 / 0.10)	48,6 (1.91)	123,4 (4.86)	155,6 (6.13)
1,6 / 6,2 (0.10 / 0.38)	40,1 (1.58)	115,0 (4.53)	155,6 (6.13)	7,9 / 1,2 (0.48 / 0.07)	51,8 (2.04)	129,0 (5.08)	160,4 (6.31)
2,5 / 4,4 (0.15 / 0.27)	41,7 (1.64)	114,7 (4.52)	152,0 (5.98)	7,9 / 2,5 (0.48 / 0.15)	51,8 (2.04)	131,4 (5.17)	165,1 (6.50)
2,5 / 4,8 (0.15 / 0.29)	41,7 (1.64)	115,5 (4.55)	153,5 (6.04)				

**GP1-\*R-RBCB-SGBGB-N002**

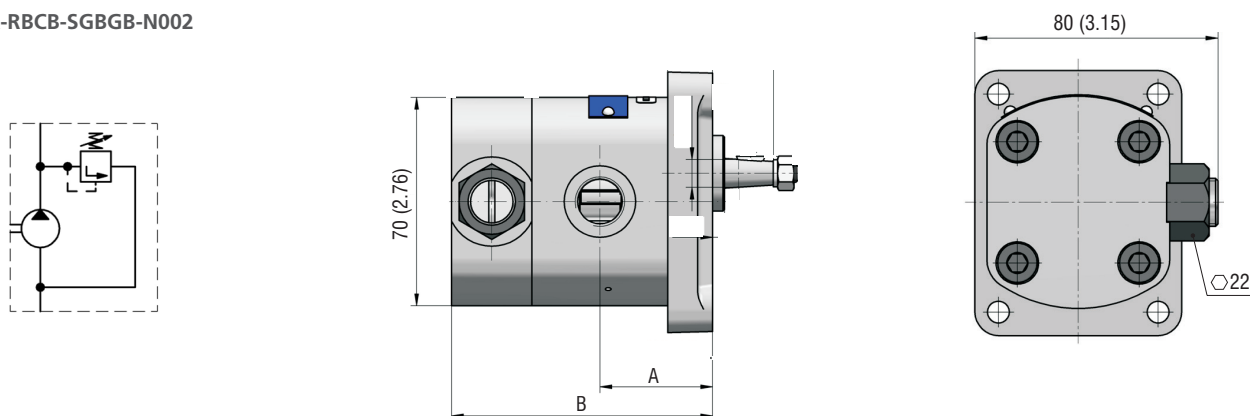

Displacement [cm <sup>3</sup> (in <sup>3</sup> )/rev]	A	B	Displacement [cm <sup>3</sup> (in <sup>3</sup> )/rev]	A	B
0,8 (0.05)	32,6 (1.28)	77,3 (3.04)	3,6 (0.22)	37,8 (1.49)	87,6 (3.45)
1,2 (0.07)	33,4 (1.31)	78,8 (3.10)	4,4 (0.27)	39,2 (1.54)	90,5 (3.56)
1,6 (0.10)	34,1 (1.34)	80,3 (3.16)	4,8 (0.29)	40,0 (1.57)	92,0 (3.62)
2,1 (0.13)	34,9 (1.37)	81,9 (3.22)	5,8 (0.35)	41,9 (1.65)	95,8 (3.77)
2,5 (0.15)	35,7 (1.41)	83,5 (3.29)	6,2 (0.38)	42,6 (1.68)	97,3 (3.83)
3,3 (0.20)	37,2 (1.46)	86,5 (3.41)	7,9 (0.48)	45,8 (1.80)	103,6 (4.08)

**GP1 Pumps - special design** in millimeters (inches)

**Single pump P23-\*\*L-AGCG-AGBPA-N014**

**Double pump P23-\*\*/\*L-AGCG-CGBPA/GBGBGB-N014**

014 - Special design for SMA 05 hydraulic units:

Flange AE with pressure port PA

Shaft prolonged

