



High Pressure Filters – Worldline 100

HD 049 • HD 069

- In-line mounting
- Operating pressure up to 630 bar
- Nominal flow rate up to 105 l/min

Description

Application

In the high pressure circuits of hydraulic systems.

Performance features

Protection

against wear: By means of filter elements that, in full-flow filtration, meet even the highest demands regarding cleanliness classes.

Protection against malfunction: Through installation near to the control valves or other expensive components. The specific determined flow rate guarantees a closed by-pass valve even at $\leq 200 \text{ mm}^2/\text{s}$ (cold start condition).

Filter elements

Flow direction from outside to centre. The star-shaped pleating of the filter material results in:

- large filter surfaces
- low pressure drop
- high dirt-holding capacities
- long service life

Filter maintenance

By using a clogging indicator the correct moment for maintenance is stated and guarantees the optimum utilization of the filter life.

Materials

Filter head: Spheroidal graphite cast iron (SGI)
Filter bowl: Cold extruded steel
Coating: Powder paint resp. phosphate coating / primed
Seals: NBR (FPM on request)
Filter media: EXAPOR®MAX 2 - inorganic multi-layer microfibre web
Paper - cellulose web, impregnated with resin

Accessories

If an electrical indicator is used a transparent socket with LED for optical indication is also available with Part No. DG 041.1200.

Characteristics

Operating pressure

0 ... 400 bar, min. 2×10^6 pressure cycles
Nominal pressure according to DIN 24550

0 ... 630 bar, min. 10^4 pressure cycles
Quasi-static operating pressure

Permissible pressures for other numbers of cycles

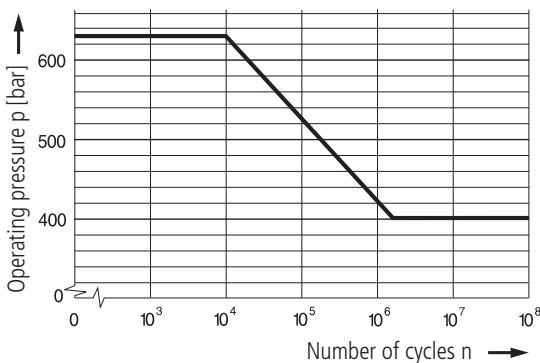

Nominal flow rate

Up to 105 l/min (see Selection Chart, column 2)
The nominal flow rates indicated by ARGO-HYTOS are based on the following features:

- closed by-pass valve at $v \leq 200 \text{ mm}^2/\text{s}$
- element service life > 1.000 operating hours at an average fluid contamination of 0,07 g per l/min flow volume
- flow velocity in the connection lines:
 - up to 250 bar $\leq 8 \text{ m/s}$
 - > 250 bar $\leq 12 \text{ m/s}$

Filter fineness

$5 \mu\text{m(c)} \dots 30 \mu\text{m(c)}$
 β -values according to ISO 16889
(see Selection Chart, column 4 and diagram Dx)

Dirt-holding capacity

Values in g test dust ISO MTD according to ISO 16889
(see Selection Chart, column 5)

Hydraulic fluids

Mineral oil and biodegradable fluids
(HEES and HETG, see info-sheet 00.20).

Temperature range

-30 °C ... +100 °C (temporary -40 °C ... +120 °C)

Viscosity at nominal flow rate

- at operating temperature: $v < 60 \text{ mm}^2/\text{s}$
- as starting viscosity: $v_{\text{max}} = 1.200 \text{ mm}^2/\text{s}$
- at initial operation: The recommended starting viscosity can be read from the diagram D (pressure drop as a function of the kinematic viscosity) as follows: Find the 70 % Δp of the cracking pressure of the by-pass valve on the vertical axis. Draw a horizontal line so that it intersects the Δp curve at a point. Read this point on the horizontal axis for the viscosity.

Mounting position

Preferably vertical, filter head on top

Connection

Threaded ports according to ISO 228 or DIN 13. Sizes see Selection Chart, column 6 (other port threads on request).

Electrical clogging indicator

- Switching voltage: max. 120 V AC / 175 V DC
- Switching current: max. 0,17 A AC / 0,25 A DC
- Switching power: max. 3,5 VA AC / 5 W DC
- Type of contact: Change-over
- Electrical protection: IP 65 (with mounted and secured socket)

Diagrams

Δp -curves for complete filters in Selection Chart, column 3

D1 Pressure drop as a function of the **flow volume**
at $v = 35 \text{ mm}^2/\text{s}$ (0 = casing empty)

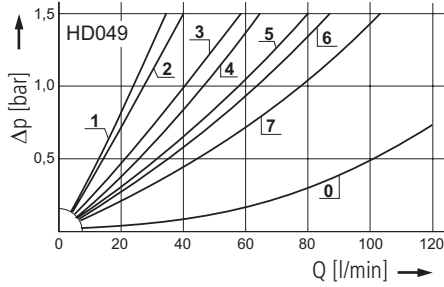

Pressure drop as a function of the **kinematic viscosity**
at nominal flow

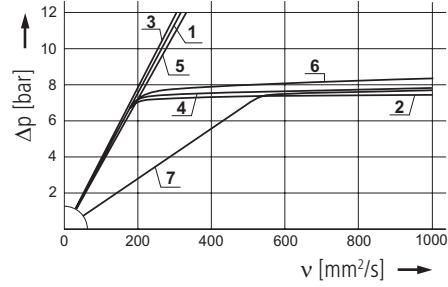

D2 Pressure drop as a function of the **flow volume**
at $v = 35 \text{ mm}^2/\text{s}$ (0 = casing empty)

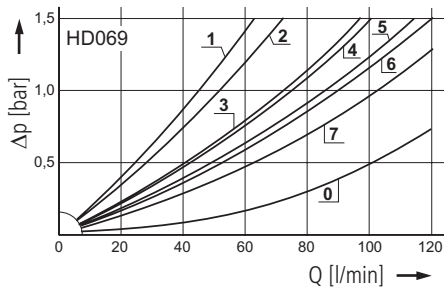

Pressure drop as a function of the **kinematic viscosity**
at nominal flow

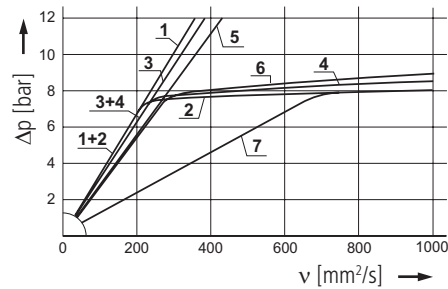

Filter fineness curves in Selection Chart, column 4

Dx Filtration ratio β as a function of particle size x obtained by the
Multi-Pass Test according to ISO 16889

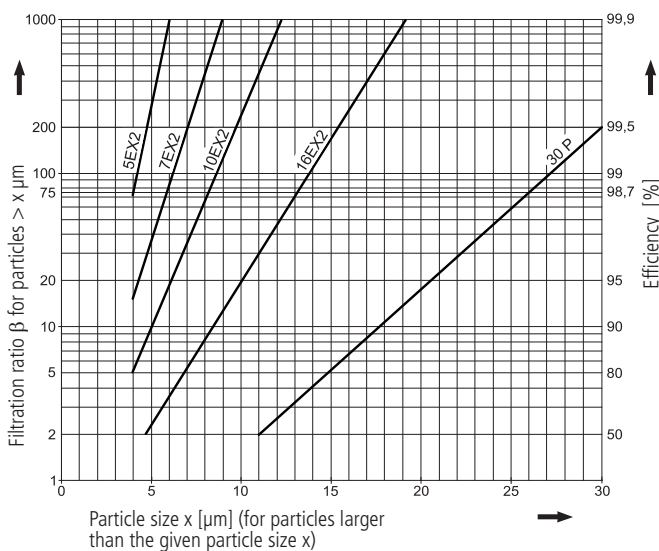

The abbreviations represent the following β -values resp. finenesses:

For EXAPOR[®]MAX 2 and Paper elements:

5EX2 = $\beta_{5(c)} = 200$ EXAPOR[®]MAX 2

7EX2 = $\beta_{7(c)} = 200$ EXAPOR[®]MAX 2

10EX2 = $\beta_{10(c)} = 200$ EXAPOR[®]MAX 2

16EX2 = $\beta_{16(c)} = 200$ EXAPOR[®]MAX 2

30P = $\beta_{30(c)} = 200$ Paper

Based on the structure of the filter media of the 30P paper elements, deviations from the printed curves are quite probable.

For screen elements:

40S = screen material with mesh size 40 μm

60S = screen material with mesh size 60 μm

100S = screen material with mesh size 100 μm

Tolerances for mesh size according to DIN 4189

For special applications, finenesses differing from these curves are also available by using special composed filter media.

Selection Chart

Part No.	Nominal flow rate	Pressure drop see diagram D /curve no.	Filter fineness see diagram Dx	Dirt-holding capacity	Connection A/B	Cracking pressure of by-pass	Symbol	Replacement element Part No.	Weight	Clogging indicator	Cracking pressure in ()	Remarks
	l/min			g		bar			kg		bar	
1	2	3	4	5	6	7	8	9	10	11	12	
HD 049-189	27	D1/1	5EX2	5,2	G½	-	6	V3.0510-13 ¹	3,9	electrical (5)		change-over
HD 049-169	30	D1/2	5EX2	4,9	G½	7	1	V3.0510-03	3,8	-		-
HD 049-179	30	D1/2	5EX2	4,9	G½	7	2	V3.0510-03	3,9	optical (5)		-
HD 049-159	30	D1/2	5EX2	4,9	G½	7	3	V3.0510-03	3,9	electrical (5)		change-over
HD 049-186	47	D1/3	10EX2	5,1	G½	-	6	V3.0510-16 ¹	3,9	electrical (5)		change-over
HD 049-166	50	D1/4	10EX2	6,8	G½	7	1	V3.0510-06	3,8	-		-
HD 049-176	50	D1/4	10EX2	6,8	G½	7	2	V3.0510-06	3,9	optical (5)		-
HD 049-156	50	D1/4	10EX2	6,8	G½	7	3	V3.0510-06	3,9	electrical (5)		change-over
HD 049-188	65	D1/5	16EX2	5,6	G½	-	6	V3.0510-18 ¹	3,9	electrical (5)		change-over
HD 049-268	75	D1/6	16EX2	6,9	M18 x 1,5	7	1	V3.0510-08	3,8	-		³
HD 049-168	75	D1/6	16EX2	6,9	G½	7	1	V3.0510-08	3,8	-		-
HD 049-178	75	D1/6	16EX2	6,9	G½	7	2	V3.0510-08	3,9	optical (5)		-
HD 049-158	75	D1/6	16EX2	6,9	G½	7	3	V3.0510-08	3,9	electrical (5)		change-over
HD 049-151	55	D1/7	30P	3,6	G½	7	1	P3.0510-11 ²	3,8	-		-
HD 049-161	55	D1/7	30P	3,6	G½	7	2	P3.0510-11 ²	3,9	optical (5)		-
HD 049-171	55	D1/7	30P	3,6	G½	7	3	P3.0510-11 ²	3,9	electrical (5)		change-over
HD 069-189	50	D2/1	5EX2	8,7	G½	-	6	V3.0520-13 ¹	5,1	electrical (5)		change-over
HD 069-169	60	D2/2	5EX2	10	G½	7	1	V3.0520-03	4,9	-		-
HD 069-179	60	D2/2	5EX2	10	G½	7	2	V3.0520-03	5,0	optical (5)		-
HD 069-159	60	D2/2	5EX2	10	G½	7	3	V3.0520-03	5,0	electrical (5)		change-over
HD 069-186	80	D2/3	10EX2	11	G¾	-	6	V3.0520-16 ¹	5,1	electrical (5)		change-over
HD 069-166	85	D2/4	10EX2	14	G¾	7	1	V3.0520-06	4,9	-		-
HD 069-176	85	D2/4	10EX2	14	G¾	7	2	V3.0520-06	5,0	optical (5)		-
HD 069-156	85	D2/4	10EX2	14	G¾	7	3	V3.0520-06	5,0	electrical (5)		change-over
HD 069-188	100	D2/5	16EX2	12	G¾	-	6	V3.0520-18 ¹	5,1	electrical (5)		change-over
HD 069-268	105	D2/6	16EX2	15	G¾	7	1	V3.0520-08	4,9	-		³
HD 069-168	105	D2/6	16EX2	15	G¾	7	1	V3.0520-08	4,9	-		-
HD 069-178	105	D2/6	16EX2	15	G¾	7	2	V3.0520-08	5,0	optical (5)		-
HD 069-158	105	D2/6	16EX2	15	G¾	7	3	V3.0520-08	5,0	electrical (5)		change-over
HD 069-151	80	D2/7	30P	7,1	G¾	7	1	P3.0520-01 ²	4,9	-		-
HD 069-161	80	D2/7	30P	7,1	G¾	7	2	P3.0520-01 ²	5,0	optical (5)		-
HD 069-171	80	D2/7	30P	7,1	G¾	7	3	P3.0520-01 ²	5,0	electrical (5)		change-over

Remarks:

- The filters listed in this chart are standard filters. If modifications are required, e.g. bolt mounted indicators according to catalogue sheet 60.30, we kindly ask for your request.
- If an electrical indicator is used a transparent socket with LED for optical indication is also available with Part No. DG 041.1200.

¹ Element differential pressure up to 160 bar

² Paper media supported with metal gauze

³ Housing primed /phosphated

Dimensions

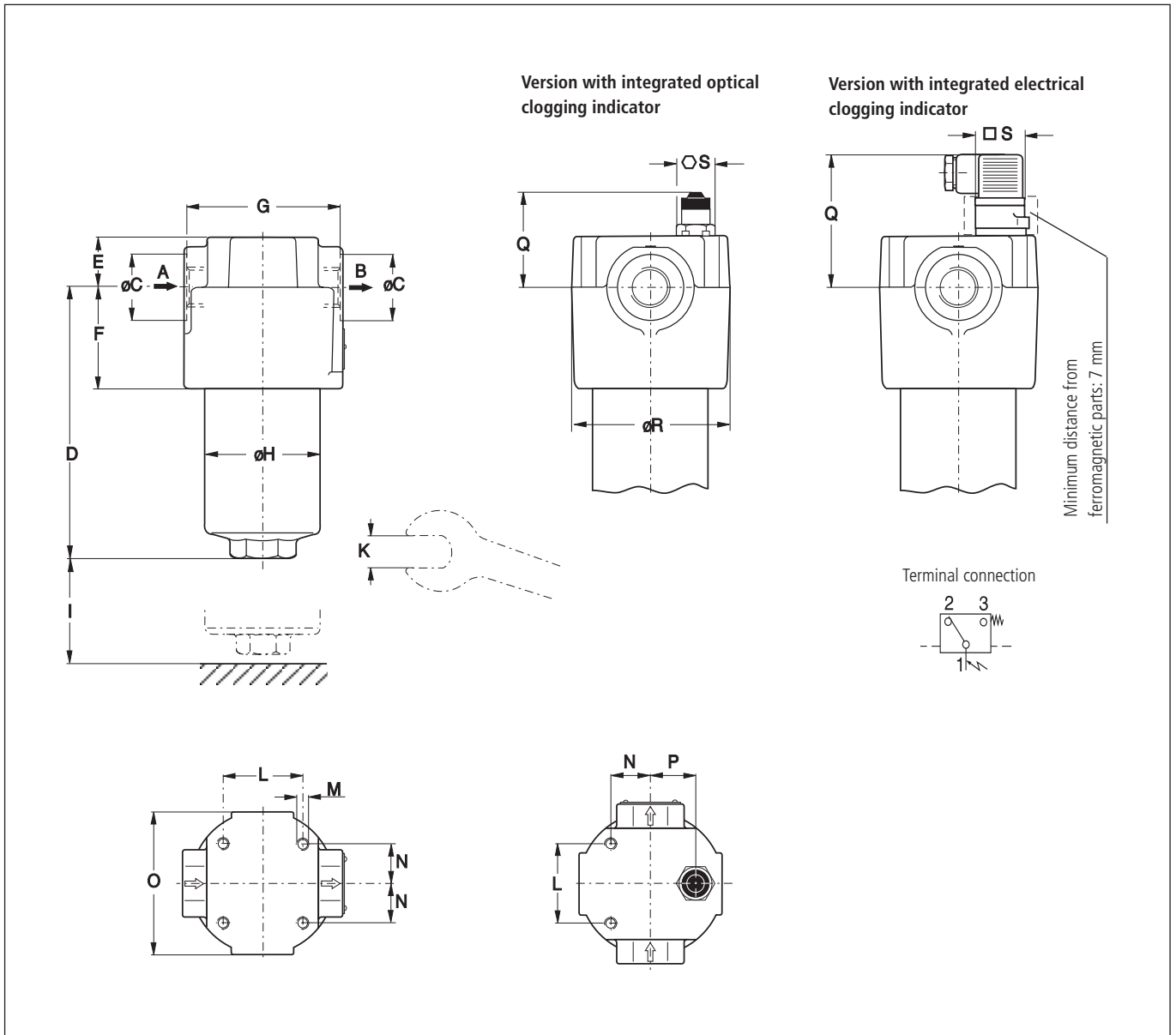

Measurements

Type	A/B	C	D	E	F	G	H	I	K	L	M	N	O	P	Q	R	S
											Ø/depth				opt./electr.		opt./electr.
HD 049	G½, M18 x 1,5	28 resp. 33	158	24,5	61	84	65	55	36	40	M8/12	25	89	27,5	55/72	85	24/30
HD 069	G½, G¾	33 resp. 36	254	24,5	61	84	65	55	36	40	M8/12	25	89	27,5	55/72	85	24/30

Symbols

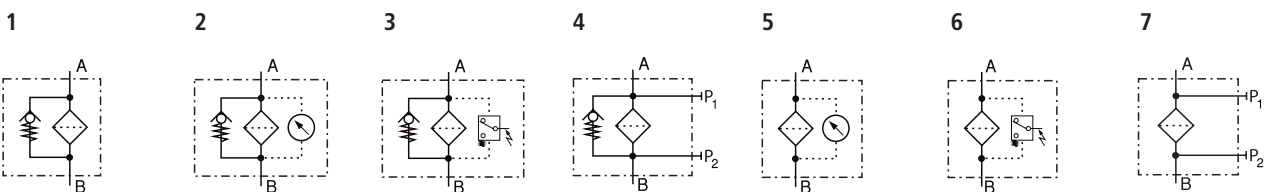

Spare Parts

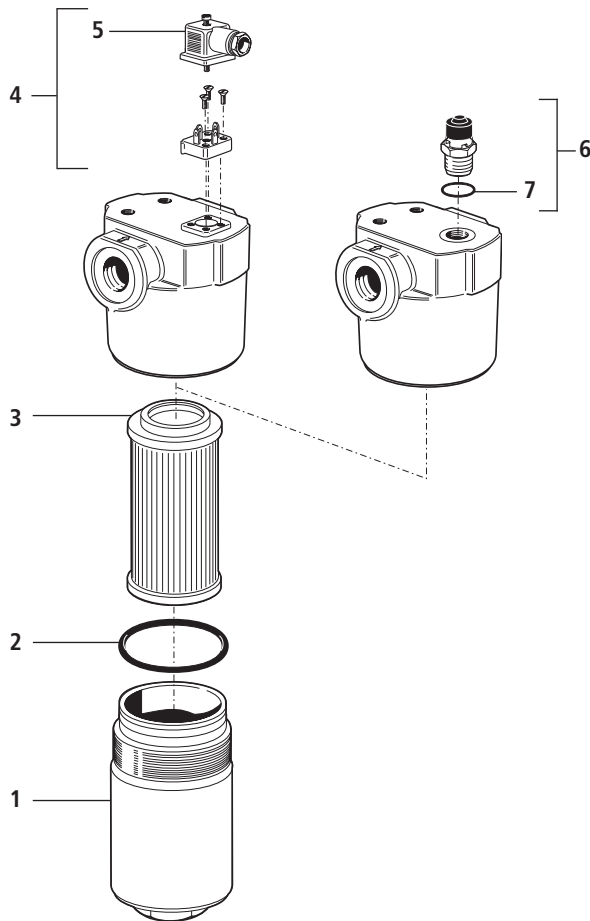

Pos.	Designation	Part No.
1	Filter bowl HD 049	HD 052.0102
1	Filter bowl HD 069	HD 072.0102
2	O-ring 53,57 x 3,53	N007.0543/1
3	Filter element	s. Chart / col. 9
4	Reed switch with screws and socket (Pos. 5)	HD 049.1410
5	Socket DIN 43650 - AF3	DG 041.1220
6	Optical indicator (with Pos. 7)	HD 049.1400
7	O-ring 17 x 2	N007.0172

The functions of the complete filters as well as the outstanding features of the filter elements assured by ARGO-HYTOS can only be guaranteed if original ARGO-HYTOS spare parts are used.

Quality Assurance

Quality management according to DIN EN ISO 9001

To ensure constant quality in production and operation, ARGO-HYTOS filter elements undergo strict controls and tests according to the following ISO standards:

ISO 2941	Verification of collapse/burst pressure rating
ISO 2942	Verification of fabrication integrity (Bubble Point Test)
ISO 2943	Verification of material compatibility with fluids

ISO 3968	Evaluation of pressure drop versus flow characteristics Multi-Pass-Test (evaluation of filter fineness and dirt-holding capacity)
ISO 16889	
ISO 23181	Determination of resistance to flow fatigue using high viscosity fluid

Before release into the series production the filter casing is tested for fatigue strength in our pressure pulse test rig. Various quality controls during the production process guarantee the leakfree function and solidity of our filters.

Our engineers will be glad to advise you in questions concerning filter application, selection as well as the cleanliness class of the filtered medium attainable under practical operating conditions.

Illustrations may sometimes differ from the original. ARGO-HYTOS is not responsible for any unintentional mistake in this specification sheet.

We produce fluid power solutions

ARGO-HYTOS GMBH · Industriestraße 9 · 76703 Kraichtal-Menzingen · Germany
Phone: +49 7250 76-0 · Fax: +49 7250 76-199 · info@argo-hytos.com · www.argo-hytos.com

Subject to change
40.45-3e · 0714