



**MANUALE D'USO E INSTALLAZIONE / INSTRUCTION MANUAL
NOTICE D'UTILISATION ET INSTALLATION / MANUAL DE USO E INSTALACIÓN
BETRIEBS- UND INSTALLATIONSANLEITUNG**

Dati tecnici e prestazioni - Technical and Performance Data								
Données techniques et performances - Datos técnicos y prestaciones								
Technische Daten und Leistungsmerkmale								
Modello	Portata		Pressione massima di esercizio		Potenza assorbita		Numero giri massimo	Peso
Model	Delivery rate		Maximum operating pressure		Power absorption		Maximum rpm	Weight
Modèle	Débit		Pression de servicemaximale		Puissance absorbée		Nombre de tours maximal	Poids
Modell	Förderleistung		Max. Betriebsdruck		Leistungsaufnahme		Max. Drehzahl	Gewicht
Modelo	Caudal		Presión máxima de servicio		Potencia absorbida		Número máximo de rpm	Peso
	l/min	gpm	bar	psi	Hp	kW	rpm	kg
XWF 26.06 N	26	6.87	60	900	4	3	1000	16
XWF 26.09 N	26	6.87	90	1300	5.5	4	1000	16
XWF 26.12 N	26	6.87	120	1740	7.5	5,5	1000	16
XWF 26.15 N	26	6.87	150	2200	10	7,5	1000	16
XWF 26.20 N	26	6.87	200	2900	13	9,6	1000	16
XWF 30.10 N	30	7.92	100	1450	7.5	5,5	1000	16
XWF 30.18 N	30	7.92	180	2600	15	11	1000	16
XWF 30.20 N	30	7.92	200	2900	15	11	1000	16
XWF 36.17 N	36	9.51	170	2500	15	11	1000	16
XW 15.15 N	15	3.96	150	2200	5.5	4	1450	16
XW 15.20 N	15	3.96	200	2900	7.5	5,5	1450	16
XW 15.30 N	15	3.96	300	4350	12	8,7	1450	16
XW 21.20 N	21	5.55	200	2900	10	7,5	1450	16
XW 21.25 N	21	5.55	250	3600	12.5	9,2	1450	16
XW 21.28 N	21	5.55	280	4060	15	11	1450	16
XW 26.12 N	26	6.87	120	1740	7.5	5,5	1450	16
XW 26.15 N	26	6.87	150	2200	10	7,5	1450	16
XW 26.20 N	26	6.87	200	2900	12.5	9,2	1450	16
XW 26.23 N	26	6.87	230	3400	15	11	1450	16
XW 30.10 N	30	7.92	100	1450	7.5	5,5	1450	16
XW 30.15 N	30	7.92	150	2200	10	7,5	1450	16
XW 30.20 N	30	7.92	200	2900	15	10	1450	16
XW 30.25 N	30	7.92	250	3600	19	14	1450	16
XWL 36.15 N	36	9.51	150	2200	15	11	1450	16



**Istruzioni originali
Original instructions
Notices originales
Originalanleitung
Instrucciones originales**

Edizione - Edition - Édition - Ausgabe - Edición: 05/2014

N° codice manuale
Manual code no.
N° code de la notice
Kode der Betriebs- und
Installationsanleitung
N° código manual

91425



Dati tecnici e prestazioni - Technical and Performance Data
Données techniques et performances - Datos técnicos y prestaciones
Technische Daten und Leistungsmerkmale

Modello Model Modèle Modell Modelo	Portata Delivery rate Débit Förderleistung Caudal		Pressione massima di esercizio Maximum operating pressure Pression de servicemaximale Max. Betriebsdruck Presión máxima de servicio		Potenza assorbita Power absorption Puissance absorbée Leistungsaufnahme Potencia absorbida		Numero giri massimo Maximum rpm Nombre de tours maximal Max. Drehzahl Número máximo de rpm	Peso Weight Poids Gewicht Peso
	l/min	gpm	bar	psi	Hp	kW	rpm	kg
XWL 41.20 N	41	10.83	200	2900	20	15	1450	16
XWL 42.05 N	42	11.09	50	725	5.5	4	1450	16
XWL 42.07 N	42	11.09	70	1000	8	5,9	1450	16
XWL 42.10 N	42	11.09	100	1450	11	8,2	1450	16
XWL 42.15 N	42	11.09	150	2200	16	11,8	1450	16
XWL 50.15 N	50	13.2	150	2200	20	15	1450	16
XWL 50.15 H N	50	13.2	150	2200	20	15	1450	16

Temperatura massima liquido aspirato Max. Temperatur der Förderflüssigkeit	Maximum intake liquid temperature Temperatura máxima líquido aspirado	Température maximale du liquide aspiré	40°C

Pag.

Italiano	3
----------	---

English	22
---------	----

Français	41
----------	----

Deutsch	60
---------	----

Español	80
---------	----



SUMMARY

1	GENERAL INFORMATION	23
2	TECHNICAL INFORMATION	25
3	SAFETY INFORMATION	28
4	HANDLING AND TRANSPORT INSTRUCTIONS	29
5	INSTALLATION INSTRUCTIONS	30
6	INSTRUCTIONS FOR USE	33
7	MAINTENANCE INSTRUCTIONS.....	35
8	TROUBLESHOOTING.....	39

TABLE OF CONTENTS

A		R	
After-Sales service procedures	24	Residual risks	25
Annexes.....	99	S	
Annexed documentation	24	Safety recommendations for handling and lifting	29
C		Safety recommendations for installation.....	30
Changing the oil.....	37	Safety recommendations for maintenance.....	35
Checking the oil level.....	37	Safety recommendations for use	33
Connection to an auxiliary pump (force-feed).....	32	Scrapping the pump.....	38
Connection to a tank (gravity-feed).....	32	Starting and stopping the pump when supplied by an auxiliary pump.....	34
Connection to the mains water supply	31	Starting and stopping the pump when supplied by gravity-feed	33
D		Starting and stopping the pump when supplied by the mains water system.....	33
Declaration of incorporation.....	27	Storage.....	29
Disclaimer	24	T	
E		Table of lubricants	36
Environmental operating limits	26	Technical Data.....	26
G		Transport.....	29
General description	25		
General guidelines on water supply connection ...	31		
General safety rules	28		
Glossary	24		
I			
Inspecting the connections and pipes.....	37		
Inspecting the Filter.....	37		
Inspecting the pump mounting	37		
Installation.....	30		
Intended uses.....	25		
L			
Lengthy pump lay-offs	38		
M			
Main components	25		
Misuses.....	25		
Mounting the pump	30		
O			
Overall dimensions	26		
P			
Packaging description and unpacking.....	29		
Pump and manufacturer identification	23		
Purpose of the manual	23		
Putting the pump back into service	38		



Purpose of the manual

The manufacturer has provided this manual to provide the operating instructions and the criteria to be complied with when installing, using and maintaining the pump identified by designation on the cover.

The manufacturer supplies the original instructions in english language.

The manufacturer may supply the original instructions in other languages in response to statutory or commercial requirements.

If the pump is sold, the seller must pass on this manual to the new owner along with the appliance.

The instructions are intended for the skilled, suitably trained operators who carry out the installation and routine maintenance procedures.

Refer to the table of contents for rapid access to the topics covered.

The manufacturer reserves the right to amend the manual without notice, unless the amendments refer to the pump's level of safety.

The purchaser must ensure that the installation is designed in accordance with the instructions in this manual, statutory requirements, and the relevant national and local regulations.

The technical instructions in this "Use and Installation Manual" are the property of the manufacturer and must be treated as confidential.

There may be differences between the illustrations and the pump's actual conformation, but any such differences will not affect the clarity of the instructions. If in doubt, request the necessary explanations from the manufacturer.

The symbols shown and described below are used to identify safety risks or important information.



Danger - Warning

Identifies information or procedures the failure to comply with which may constitute a serious threat to health and safety.



Caution

Identifies information or procedures the failure to comply with which may constitute a threat to health and safety or cause damage.



Information

Identifies useful and important information or procedures which should be borne in mind.

Pump and manufacturer identification

Data plate

The data plate shown here, containing essential information for safe operation, is affixed to every pump.

- A) Manufacturer's logo
- B) Serial number barcode
- C) Model
- D) Maximum pressure (bar or psi)
- E) Serial number
- F) Lubricant specifications
- G) Maximum rpm
- H) Maximum delivery rate (l/min or U.S. gpm)

Manufacturer's name and address

Annovi Reverberi Spa
Via Martin Luther King, 3
41122 Modena (MO) - Italy

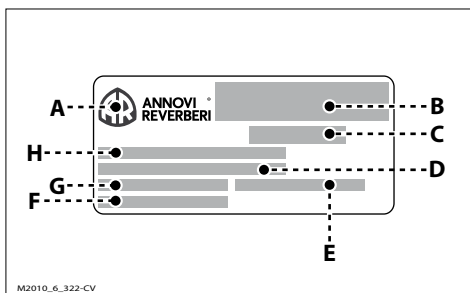

M2010_6_322-CV



After-Sales service procedures

To request after-sales service (in the event of a pump malfunction or failure, etc.) contact your nearest service centre or the manufacturer.

When requesting after-sales services, always state the pump's data plate data and the type of problem.

Disclaimer

The manufacturer accepts no liability arising from:

- incorrect installation;
 - improper use of the pump;
 - failure to service the pump;
 - unauthorised modifications and/or repairs;
 - use of non-original spare parts, or parts not specifically intended for the model.
-

Annexed documentation

The following documentation is issued to the Customer together with this manual:

- declaration of incorporation
-

Glossary

Purchaser: individual, organisation or company which has purchased the pump and intends to use it for the intended purposes.

Routine maintenance: all operations required to keep the pump in good working order, to ensure a longer working life and maintain compliance with safety requirements. The manufacturer describes the maintenance procedures and intervals in this "Use and Installation Manual".

Repairs: all operations performed to conserve the pump's efficiency and operating characteristics. These procedures, required in the event of an unexpected malfunction, must only be carried out by a skilled technician. The information for the use of skilled repair technicians only is provided in the "Repairs Manual".

Operator: authorised person having the prerequisites, skills and information needed for use of the pump or the machine or plant on which the pump is installed, and for routine maintenance procedures.

Installer: authorised technician having the prerequisites and the specific skills required for the tasks involved in the installation of the pump and/or similar machinery and for the performance of the routine maintenance operations in conditions of safety, independently and without risk.

Training: a phase necessary to transfer to the operators the knowledge needed for the correct, risk-free performance of operations.

General description

The pump is designed and constructed to pump and compress liquids at high pressure in industrial applications. The pumping action is provided by a series of pistons connected to the drive shaft by connecting-rods.

When in operation, the pistons perform an axial stroke inside the head, where the intake and delivery ducts are fitted with valves which allow the liquid to pass in one direction only.

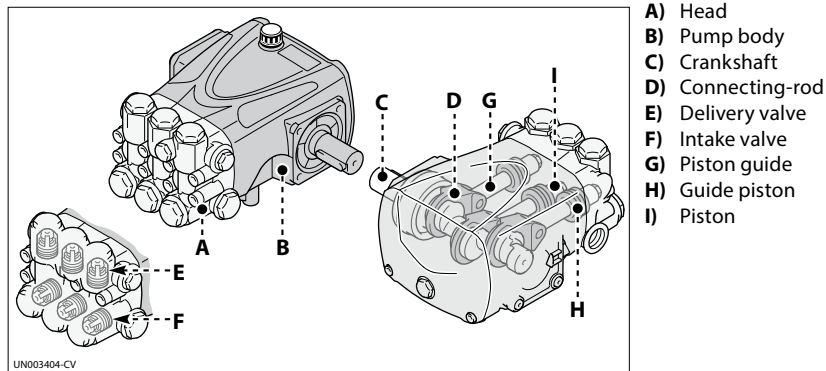
Main components

Intended uses

The pump is designed and built for incorporation in machinery and plants (machinery for washing raw materials, finished products, etc.).

The pump must be used in a manner appropriate to its technical data (see "Technical Data"), and must not be modified or improperly used.

Misuses

Do not put the pump into service until the plant or machinery in which it is incorporated has been declared compliant with the relevant national and local legal requirements.

Do not use the pump in a potentially explosive atmosphere.

Do not use the pump for flammable, toxic or corrosive liquids, or those with unsuitable density. Do not take in liquids at temperatures higher than those specified in the technical data.

Do not use the pump for the supply of drinking water.

Do not use the pump on products for human consumption.

Do not use the pump on pharmaceutical products.

Residual risks

Even if the safety regulations and information provided in the manual is complied with, the residual risk described below is still present during use of the pump.

- **Thermal hazard:** depending on the temperature of the liquid pumped, the pump may reach high temperatures when in operation. The designer of the installation must therefore bear this in mind and provide the appropriate measures and warning signs for staff.



Technical Data

The technical and performance data are stated on the cover.

The pump's intake circuit must include a filter having capacity at least twice the pump's delivery rate, which must not cause restrictions or headlosses. The recommended degree of filtration is 50÷80 mesh. Maximum intake vacuum - 0.25 bar, measured at the pump intake.

Overall dimensions

The illustrations showing the overall dimensions are provided in the **annexes**.

Environmental operating limits

The pump operates correctly at an ambient temperature between 10 and 35 °C, with relative humidity of 80%.

**Declaration of incorporation**

The illustration shows a copy of the declaration of incorporation, the original of which is issued by the manufacturer together with this manual.

**DECLARATION OF INCORPORATION**

(Ann. IIB. DIR. 2006/42/EC)

THE MANUFACTURER

ANNOVI REVERBERI S.p.A

Via Martin L. King,3 41122 Modena (ITALY)

DECLARES THAT THE PARTLY COMPLETED MACHINERY

**HIGH PRESSURE PUMP
SERIAL NUMBER: XXXX
YEAR OF CONSTRUCTION:XXXX**

complies with the following applied essential requirements: (1.3.1 - 1.3.2 -1.3.3 - 1.3.4 - 1.3.5 -1.3.6 - 1.3.7)

Conforms to Community Directives: EN 60335-2-79 EN809

The relevant technical documentation has been compiled in compliance with annex VIII and we hereby undertake to transmit, in response to a reasoned request by the national authorities, relevant information on the partly completed machinery.

FORBIDS

The putting into service of the aforesaid partly completed machinery until the final machinery into which it is to be incorporated has been declared in conformity with the provisions of Directive 2006/42/EC.

The person authorised to compile the relevant technical documentation:
Stefano Reverberi, c/o Annovi Reverberi S.p.a. via Martin L. King, 3

Modena
07/04/2010

The Manufacturer
Stefano Reverberi
Managing Director



General safety rules

Most workplace accidents and injuries are caused by carelessness and failure to comply with common sense and safety rules.

In most cases, accidents can be avoided by predicting their possible causes and proceeding with the necessary care and attention.

A careful operator who follows the rules is the best guarantee against accidents.

Before installing and using the pump, the operators and other staff must read and understand the instructions in the manual provided and the details of the installation design.

Do not tamper with, disarm or bypass the safety devices as this may cause serious threats to health and safety.

Do not release pollutants into the environment.

Dispose of waste in accordance with statutory requirements.

Before performing any procedure, adopt appropriate safety measures in accordance with the relevant statutory occupational safety requirements and comply with the safety regulations in the manual.



Safety recommendations for handling and lifting

Before starting the operations, organise the intended working area so that the materials can be lifted and handled in safety.

Unloading, loading, handling and lifting operations must be carried out by skilled, authorised, specifically trained staff.

During lifting and handling operations, the people not involved in the operations must remain at a safe distance.

For lifting, use hooks and ropes which are free from damage and appropriate for the load to be lifted.

Packaging description and unpacking

The packaging normally consists of a cardboard box for easy, safe transport.

Depending on the quantity of goods to be shipped and the place of destination, packages may be fixed on a pallet for easier lifting and handling.

Check the weight of the item on the transport documents to allow the use of suitable lifting equipment.

When unpacking, check that all components are present and intact. If items are missing or damaged, contact the dealer or manufacturer to agree the procedures to be followed.

The packaging material must be disposed of appropriately in accordance with the relevant statutory requirements.

Transport

The pump may be shipped by a variety of means of transport (road, rail, sea or air) depending on its destination. Secure the packaging firmly to the vehicle during transport, to prevent random movement.

Storage

In the event of a lengthy period out of use, place the pump (in its packaging if possible, or otherwise protected) under cover, protected from the weather.

Do not store in places where the ambient conditions might impair the pump's operating condition over time.

The manufacturer delivers the pump with an anti-corrosion treatment valid for 1 month from the date of supply.

Safety recommendations for installation

Take all possible precautions to allow the pump to be installed in a safe, risk-free manner.

All installation phases must be taken into consideration when designing the machinery or plant in which the pump is to be installed.

The design must consider all mounting points, the means of transmission of the energy sources, and the protective and safety devices required by the relevant regulations to prevent the risk of injury.

Installation

The mechanical connection between the pump and the motive power source may be made by means of a pulley and belt, or a flexible coupling, or through a direct flanged connection to the motive power source.

The crankshaft may turn in either direction.

The water supply connection can be made equally well to the intakes on the right or left of the pump (see diagram).

Only connect the pump to filtered, clean water sources.

Unscrew the plugs fitted on the various ports in the factory by the manufacturer, and screw the plugs onto the ports not used, depending on connection requirements.

Replace the oil plug (A), used for shipment with the breather plug (B) supplied.

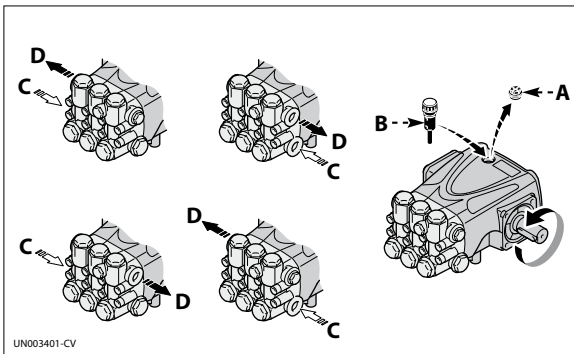

- A) Temporary oil plug
- B) Oil plug with breather
- C) Intake port
- D) Delivery port

Mounting the pump

The pump must be installed on a horizontal surface with no flexible components between it and the mounting surface.

The illustration shows the maximum permitted pump installation angle beyond which proper lubrication of the crank mechanism is not ensured.

Secure the pump with screws of suitable diameter and length, fixing them through the holes provided in the pump body.

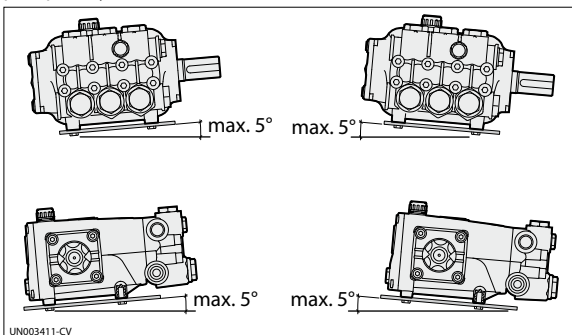

General guidelines on water supply connection

The pump's water supply connection can be made in one of the ways listed below.

- Connection to the mains water supply.
- Connection to a tank (gravity-feed).
- Connection to an external pump (force-feed).

The following requirements must be met for all types of connection.

- 1) The pump must be supplied by means of a crush-proof hose of suitable diameter for the pump's intake connection (see "Technical Data").
- 2) There must be no restrictions or kinks in the hose.
- 3) A suitable filter must be installed at the pump intake (see "Technical Data").
- 4) All connections between the unions and the intake line must be sealed to prevent the pump from sucking in air.
- 5) The connections and pipes must be suitable for the operating pressure and the pump delivery rate, and must comply with the relevant regulations.
- 6) To ensure operating safety install a relief valve (by-pass valve) suitable for the pump's technical data and with a suitable setting downstream of the pump.
- 7) The relief valve dump line must never be connected to the pump intake line.
- 8) Install a pressure damper downstream of the pump to minimise the water hammer effect in the delivery pipeline.

Connection to the mains water supply

The connection must comply with the recommendations provided.

- 1) The mains water system must have a flow rate twice the pump's rated delivery rate and a pressure of 2 - 3 bar.
- 2) Adopt all the precautions described in the "General Guidelines on Water Connections" section.

The following is a simplified illustration of the layout for connection of the pump to the mains water supply.

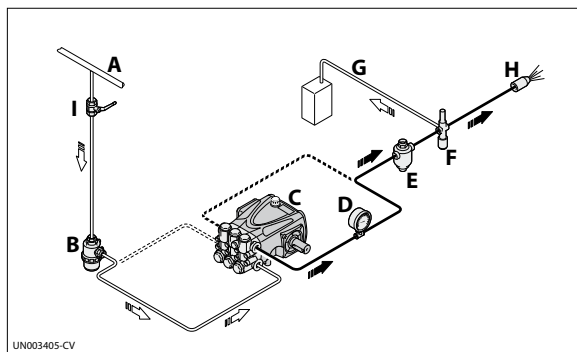

- A)** Mains water supply
- B)** Intake filter
- C)** High pressure pump
- D)** Pressure gauge
- E)** Pressure damper
- F)** Relief valve (by-pass valve)
- G)** Dump pipeline
- H)** Nozzle
- I)** Shut-off valve

Connection to a tank (gravity-feed)

The connection must comply with the recommendations provided.

- 1) The pump must be installed in a position below the tank intake (with positive head).
- 2) The tank must have baffles to prevent water splashes and its capacity must be at least 10 times greater than the pump's rated displacement.
- 3) The vacuum measured directly at the pump intake port must not exceed 0.1 bar and the water temperature must not be above 30 °C.
- 4) Adopt all the precautions described in the "General Guidelines on Water Connections" section.

The following is a simplified illustration of the layout for connection of the pump to a tank.

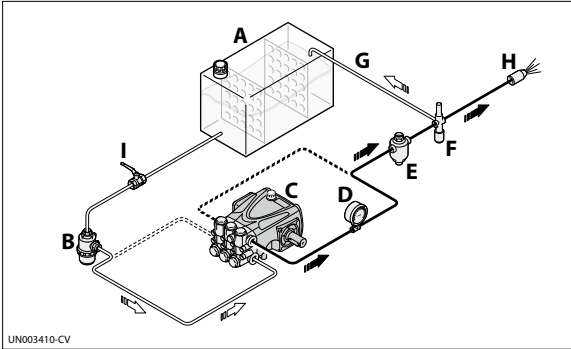

- A) Tank
- B) Intake filter
- C) High pressure pump
- D) Pressure gauge
- E) Pressure damper
- F) Relief valve (by-pass valve)
- G) Dump pipeline
- H) Nozzle
- I) Shut-off valve

Connection to an auxiliary pump (force-feed)

The connection must comply with the recommendations provided.

- 1) The auxiliary pump must have a flow rate twice the high pressure pump's rated delivery rate and an operating pressure of 2 - 3 bar.
- 2) Adopt all the precautions described in the "General Guidelines on Water Connections" section.

The following is a simplified illustration of the layout for connection of the pump to an auxiliary pump.

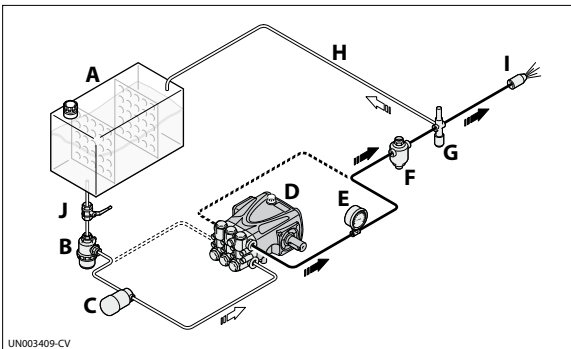

- A) Tank
- B) Intake filter
- C) Auxiliary pump
- D) High pressure pump
- E) Pressure gauge
- F) Pressure damper
- G) Relief valve (by-pass valve)
- H) Dump pipeline
- I) Nozzle
- J) Shut-off valve

Safety recommendations for use

Before start-up, the operator must perform the necessary safety checks.

In the event of leaks from the pressurised pipes, stop the pump at once and remove the cause of the leak.

Do not operate the pump above the limits set by the manufacturer to increase its performance.

If the system is to be shut down with ambient temperatures close to 0 °C, run the pump without water for 10 seconds with the end of the delivery pipeline open to empty the system and pump of water and prevent ice from forming.

Starting and stopping the pump when supplied by the mains water system

To start the pump, proceed as described below.

- 1) Open the shut-off valve (I).
- 2) Open the by-pass valve (F) to depressurise the delivery pipeline.
- 3) Start the pump and run it for a few minutes with no pressure.
- 4) Adjust the by-pass valve (F) to obtain the pump's operating pressure.

To stop the pump, proceed as described below.

- 1) Open the by-pass valve (F) to discharge the pressure.
- 2) Stop the pump.
- 3) Close the shut-off valve (I).

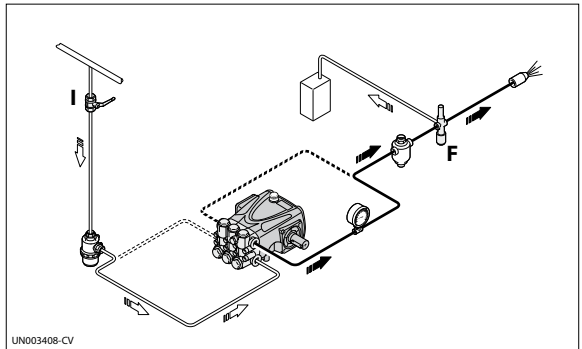

Starting and stopping the pump when supplied by gravity-feed

To start the pump, proceed as described below.

- 1) Open the shut-off valve (I).
- 2) Open the by-pass valve (F) to depressurise the delivery pipeline.
- 3) Start the pump and run it for a few minutes with no pressure.
- 4) Adjust the by-pass valve (F) to obtain the pump's operating pressure.

To stop the pump, proceed as described below.

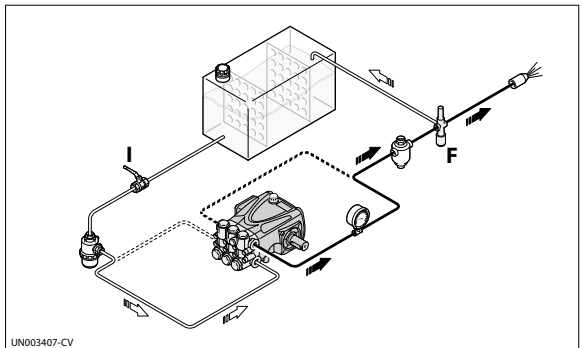
- 1) Open the by-pass valve (F) to discharge the pressure.
- 2) Stop the pump.
- 3) Close the shut-off valve (I).



Starting and stopping the pump when supplied by an auxiliary pump

To start the pump, proceed as described below.

- 1) Open the shut-off valve (**J**).
- 2) Open the by-pass valve (**G**) to depressurise the delivery pipeline.
- 3) Start the auxiliary pump (**C**).
- 4) Start the pump (**D**) and run it for a few minutes with no pressure.
- 5) Adjust the by-pass valve (**G**) to obtain the pump's operating pressure.

To stop the pump, proceed as described below.

- 1) Open the by-pass valve (**G**) to discharge the pressure.
- 2) Stop the pump (**D**).
- 3) Stop the auxiliary pump (**C**).
- 4) Close the shut-off valve (**J**).

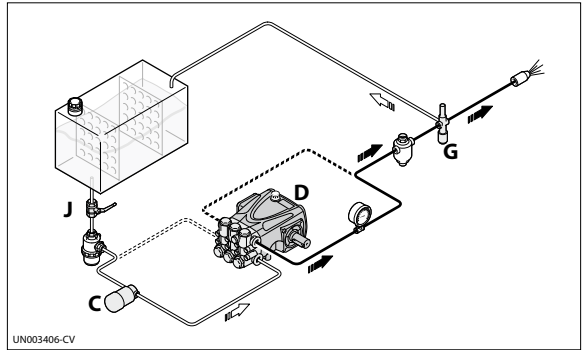

**Safety recommendations for maintenance**

Before doing any maintenance work, depressurise the water system and isolate the pump from all energy sources.

When the jobs are done, before restarting the pump, check that no tools, rags or other materials have been left close to moving parts or in hazardous zones.

Replace any excessively worn components with original parts and use the lubricants recommended by the manufacturer.

Dispose of the worn-out components and lubricants in accordance with the relevant statutory requirements.

Carry out the routine maintenance procedures specified by the manufacturer to keep the pump safe and performing well.

Scheduled service table			
Frequency	Component	Procedure	Reference
Every working day	Filter	Inspect filter cartridge	See "Inspecting the filter"
	Pump	Oil level check	See "Checking the oil level"
Every 50 working hours	Connection of pump to power source (pulley, belt, coupling)	Inspection	-
	Pump	Inspect mounting	See "Inspecting the pump mounting"
	Pipes and connections	Inspection	See "Inspecting the connections and pipes"
	Pump	Oil change (1)	See "Changing the oil"
Every 500 working hours or every year	Pump	Oil change	See "Changing the oil"
Every 1000 working hours	Pump gaskets	Replacement	Contact an authorised service centre
	Valves	Replacement	Contact an authorised service centre

(1) This interval refers to the first oil change only

Table of lubricants

The pump is delivered complete with oil, with the characteristics stated on the data plate.

When changing the oil, use an oil suitable for conditions in the operating environment (see recommendations provided in the annexes and see "Environmental operating limits").

The correct lubricating oil viscosity depends on the external temperature.

Use the graph to select the degree of viscosity best suited to the temperatures of use.

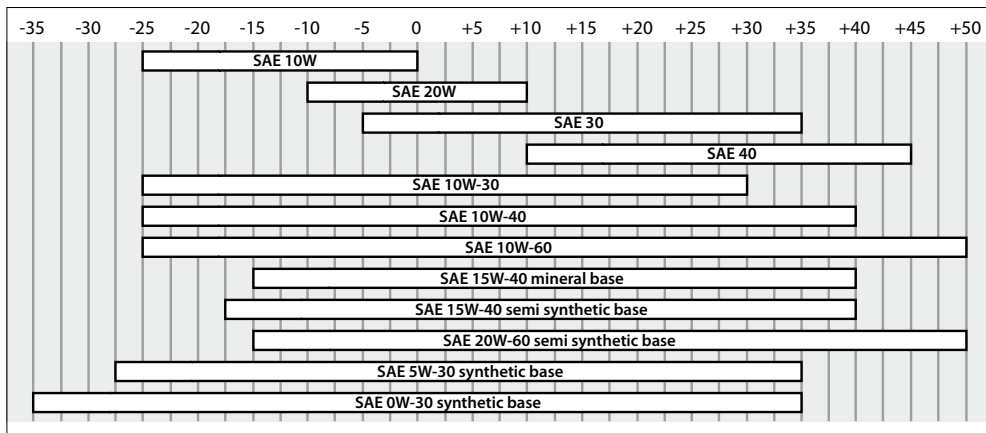
CAUTION:

the table of lubricants provided above does not apply to XM-SS, XMA-SS, RK-SS, RKA-SS, HYD RK-SS, XWL-SS, XWLA-SS, SHP, RHW-SS and WHW-SS series pumps, where only SAE 75W-90 oil may be used. For RCW, RCWS, CWX, XHW, RHW, WHW and WHWL pumps, SAE W90 may be used.

Inspecting the pump mounting

Check that the pump's fixing screws have not become loose.

If necessary, tighten them with the driving torque stated in the installation design.

Inspecting the connections and pipes

- Inspect the connections for leaks.

Leaks can normally be dealt with by tightening the connections properly.

If leaks from the intake pipeline connections are noticed, the seals must be repaired.

- Inspect the hoses.

If the pipes show signs of aging, breakage, swelling, rubbing, etc., they must be replaced.

Inspecting the Filter

- Inspect the filter cartridge.

If the filter cartridge is fouled or damaged, refer to the filter manufacturer's instructions for details of how to restore the filter cartridge to its original filtering condition.

Checking the oil level

- Check the oil with the pump level and cold.
- Check the amount of oil through the level gauge (A).
- If necessary, top up with oil with the characteristics specified in the "Lubricants table".

To top up with oil proceed as described below.

- 1) Unscrew the plug (B) and pour oil in until it is halfway up the level gauge (A).
- 2) Screw on the plug (B).

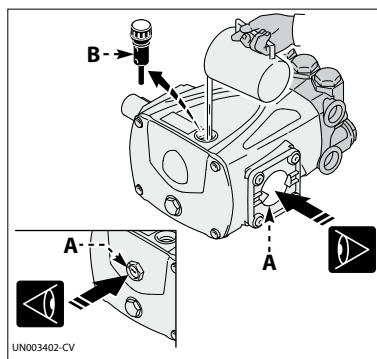

Changing the oil

Position the machine in which the pump is incorporated perfectly level, with the pump slightly warm.

Do not release oil into the environment.

Dispose of spent oil in accordance with statutory requirements.

To change the oil, proceed as described below.

- 1) Position a receptacle of suitable capacity to collect the spent oil.
- 2) Unscrew the drain plug (A) and allow all the oil to flow out.
- 3) Screw on the drain plug (A).
- 4) Unscrew the filler plug (B).
- 5) Pour in the fresh oil through the filler hole until the correct level is reached (see "Checking the oil level").
- 6) Screw on the filler plug (B).

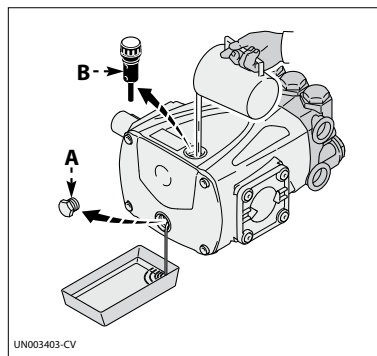



Lengthy pump lay-offs

If the pump is to be unused for a long time, proceed as described below.

- 1) Run the pump with clean water for a few minutes.
 - 2) Operate the pump without water for 10 seconds with the end of the delivery pipeline open to empty the pump and the delivery circuit and prevent scaling.
 - 3) Flush the pump with water and solvents authorised by the relevant laws.
 - 4) Dry the pump with a pressurised air jet.
 - 5) Protect the pump from weather.
-

Putting the pump back into service

Before putting the pump back into service after a long period out of use, check the oil level and the tightness of the mounting screws.

Scrapping the pump

The pump must be scrapped by skilled staff, in compliance with the statutory requirements on occupational safety.

The dismantled components must be sorted by the type of materials from which they are made. Do not dump pollutants such as seals and lubricants in the environment.

Dispose of them in accordance with statutory requirements with regard to waste disposal and recycling.



The information provided is intended to provide guidance on how to deal with malfunctions which may occur during use.

Some of these procedures may be carried out by skilled staff, while others have to be performed at specialised service centres since they require the use of specific equipment as well as detailed knowledge of repair operations.

Problem	Cause	Remedy
Pump does not reach the specified pressures	Pump sucking air	Restore the tightness of the intake line
	Intake flow rate insufficient	Increase the size of the intake pipelines
		Remove any kinks from the pipes
		Increase the filter capacity or clean the filter cartridge
		Increase the rpm to the rated speed
	Worn intake and delivery valves	Replace the valves (1)
	By-pass valve seat worn	Replace the valve
	Worn gaskets	Replace the gaskets(1)
Unsuitable, worn nozzle	Replace nozzle	
Irregular variations in pressure	Worn intake and delivery valves	Replace the valves (1)
	Valves blocked by dirt	Clean the valves (1)
	Air being sucked into system	Restore the tightness of the intake pipeline connections
	Worn gaskets	Replace the gaskets(1)
Vibrations on pipes	Valves jammed	Replace the valves (1)
	By-pass valve malfunction	Replace the by-pass valve
	By-pass valve dump line too small	Increase size of by-pass valve dump line
	Pressure damper flat	Restore pressure damper to correct inflation pressure
	Pump sucking air	Restore the tightness of the intake line
Pressure drop	Nozzle worn	Replace nozzle
	Worn intake and/or delivery valves	Replace the valves (1)
	Valves blocked by dirt	Clean the valves (1)
	By-pass valve seat worn	Replace the valve
	Worn gaskets	Replace the gaskets (1)

(1) Operations which must be carried out at an authorised service centre



Problem	Cause	Remedy
Pump noisy	Air being sucked into system	Restore the tightness of the intake pipeline connections
	Intake and/or delivery valve springs broken or collapsed	Replace the valves (1)
	Valves blocked by dirt	Clean the valves (1)
	Worn bearings	Replace the bearings(1)
	Intake liquid temperature too high	Reduce liquid temperature
Pump overheating	High pump operating pressure	Reduce the pressure to the rated values
	Drive belts too taut	Restore correct belt tension
	Pulley or drive coupling alignment poor	Restore the correct alignment
Water in oil	Guide piston gaskets worn	Replace the gaskets(1)
	High humidity percentage in air	Change the oil twice as often (than stated in "Routine Maintenance" table)
	Worn gaskets	Replace the gaskets(1)
Oil leaks from dump lines underneath the pump	Worn gaskets	Replace the gaskets(1)
	Worn pistons	Replace the pistons(1)
Oil leaks from dump lines underneath the pump	Guide piston gaskets worn	Replace the gaskets(1)

(1) Operations which must be carried out at an authorised service centre