

C13 and C16 Series - coil information

C

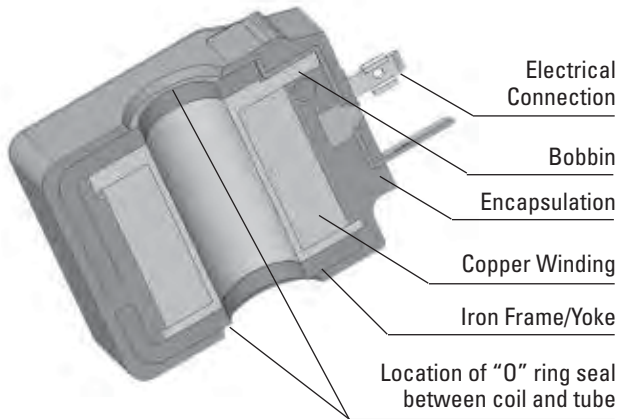

Wattage

C13 (for 13 mm tubes) = 14, 22 & 27 Watts
 C16 (for 16 mm tubes) = 19 & 29 Watts

Voltages

Standard
 12 VDC 110 VRAC
 24 VDC 220 VRAC

Special/Optional

Other Voltages are available on request

Alternating current

For AC voltage an ISO4400 rectified connector must be used, as the coils are wound for DC. The correct connector is available from the factory:

110 VAC = AXP9997-115
 220 VAC = AXP9997-230

VDR is fitted for over-voltage protection.
 Diodes are rated at 1.5 amp.

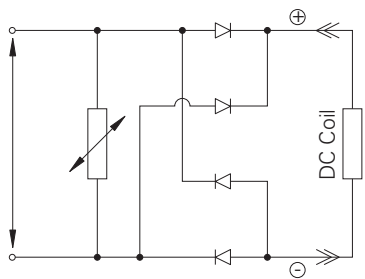

AC Voltage Connector Circuit Diagram

Duty rating

The coil is rated for continuous operation at nominal voltage +/- 10% and an ambient range of -20 to +40.

Note: Coil performance, force produced and power consumed, is affected by the heat of the coil, performance figures given in this catalogue are measured under simulated continuous duty conditions at the coil stabilized temperature. It is important to verify the actual conditions the valve will experience for any given application it should be tested in situ to confirm valve selection.

Wire insulation

The coil winding is copper magnet wire insulation equivalent to class N (200°C).

Encapsulation material

C13, 14 Watt coils and C16, 19 Watt coils are black in colour and made from PBT (Black Polybutylene Reinforced) equivalent to Class F (155°C)

C13, 22 & 27 Watt coils and C16, 29 Watt coils are black in colour and made from IXEF (Black Polyarylamide Reinforced) equivalent to Class H (180°C)

Ingress protection (IP) BS EN 60529

The coil/tube joint is sealed by "O" rings preventing fluid ingress and the possibility of tube corrosion.

Different electrical connectors offer different levels of protection the minimum being the DIN 43650 connector with a gasket at IP65. Integrated Hydraulics offer a wide range of connector types - details of which are available on request.

Connectors

- H = ISO4400 Standard DIN43650
2 pin and earth
- F = Black Flying Leads 1.5mm² wire
600 mm long, 15 AWG, 2.2 mm diameter, Teflon FEP covered (DC voltage only)
- DM = Deutsch Moulded 2 way DT04-2P series (DC voltage only).

Caution

When handling coils after or during use they may be hot which can cause burning to the skin. Handle with care and use the appropriate equipment.

Where measurements are critical request certified drawings. We reserve the right to change specifications without notice.

Model code

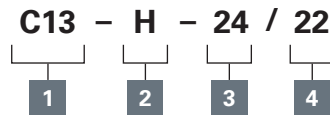

1 Coil Series

C13 - 13 mm tube
C16 - 16 mm tube

2 Connection

H - DIN43650 ISO Standard
F - Flying Leads
 (12 and 24 VDC only)
DM - Deutsch Moulded
 (12 and 24 VDC only)
 (Consult factory for other options)

3 Voltage

12	12 VDC
24	24 VDC
110	110 VRAC
220	220 VRAC*

*220 to 240 VAC

All AC coils must be used with a rectifying connector:
 (AXP9997- 115 or AXP9997-230)
 (Other voltages available on request)

4 Wattage

C13	C16
14 = 14 Watt	19 = 19 Watt
22 = 22 Watt	29 = 29 Watt
27 = 27 Watt	

We reserve the right to change specifications without notice

C13 Coils

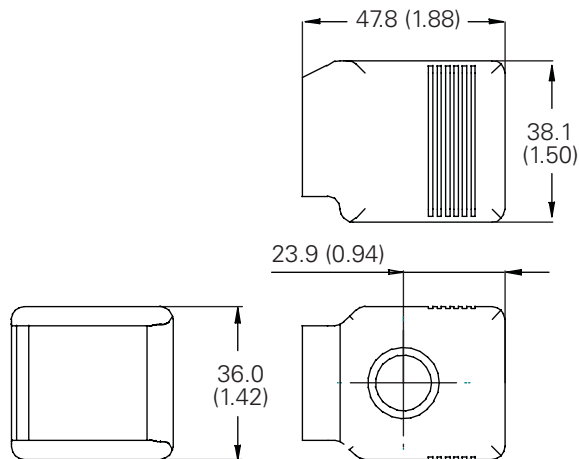

C16 Coils

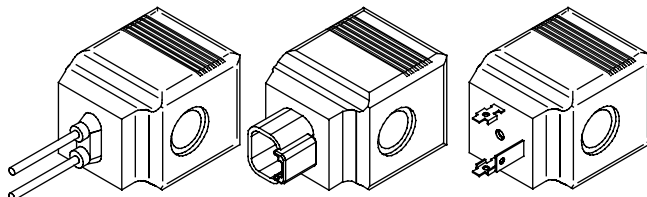
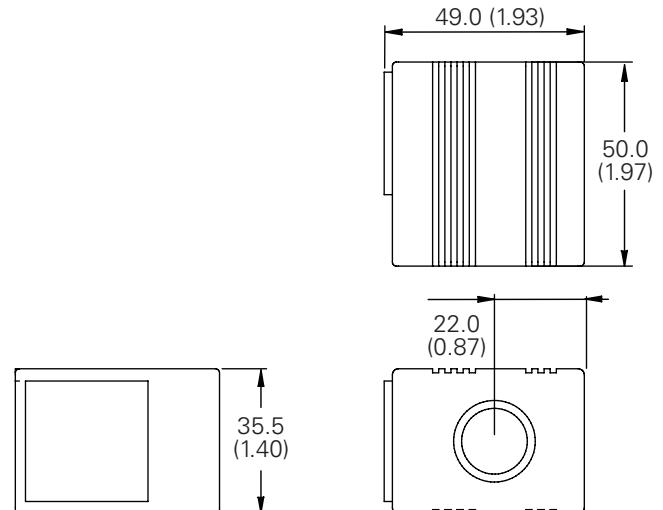

Where measurements are critical request certified drawings. We reserve the right to change specifications without notice.