

CEMO CUBE – a new generation. Redefining the Standard³.

Most fuel stations available today have been adapted from oil storage tanks and often give the appearance of being cobbled together as best as possible. Perhaps now is the time to redesign from scratch and produce a purpose designed fuel station more closely suited to today's user. CEMO present the latest in security, function and design in the CUBE. We have introduced features with benefits, not compromises and jigs. The first dispensing station to be designed as a dispensing station with everything in its place, easily accessible and straightforward to use. It's impressive – a great concept. Take a look and see if you agree.



Video
CUBE Tank



robust, lockable lid

Lockable lid secured by toggle latches. Opens upwards on supporting gas struts to allow access from three sides and plenty of light to see what you're doing.



always tidy

The automatic hose reel helps you keep 8 m of hose in order.



double protection

Integral 110 % bund gives added environmental protection.



transport friendly

Integral forklift pockets assist with loading and installation. Optimal dimensions based around Europallet measurements for ease of transport and delivery to site.



accessible

Integrated nozzle holder keeps things in place.

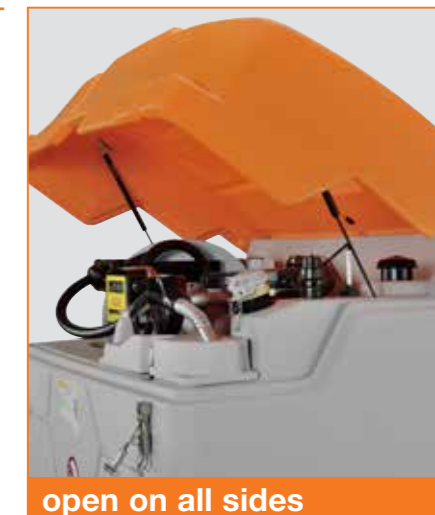

open on all sides

An open lid gives you unimpeded access to all components from three sides.



ergonomic

All equipment is positioned so that it is easy to see and access at an optimum level over the bund.

Independently tested

Ü-mark shows compliance with German building standards that insist on a minimum 25-year service life, full load bearing capacity and 30 minutes fire resistance. CE-mark shows compliance with BS EN 13341:2005&A1:2011 standard for above-ground polyethylene oil tanks.



designed-in stability

Two systems ensure stability – moulded hexagonal matrix for integral polymer strength, supported by twin steel bands at the points of greatest load. Reduces movement and increases service life.

CUBE-Dieseltank [PG 4]

Dispensing station for Diesel, Basic and Premium with general construction inspection approval no. Z-40.21-510

- comprising integral sump
- optical bund alarm
- tanker coupling
- electronic overfill sensor
- vent
- analogue contents gauge
- suction hose
- 230V electric pump 56 l/min (72 l/min on 2500 l versions)
- 4m delivery hose
- automatic nozzle with integral nozzle holder
- approved for outdoor installation with hinged lid (outdoor model)
- fully assembled



CUBE-Dieseltank 2,500l Outdoor Premium

CUBE-Dieseltank 1,000l Outdoor



CUBE-Dieseltank 1,500l Outdoor



CUBE-Dieseltank 2,500l Indoor Basic

CUBE-Dieseltank

Designation	Capacity l	External Dimensions cm (w x d x h)	Weight approx. kg	Order No.
CUBE-Tank Indoor Basic, for diesel	1500	120 x 115 x 174	165	10292*
	2500	120 x 180 x 174	220	10293***
CUBE-Tank Outdoor Basic, for diesel incl. hinged lid	1000	120 x 80 x 180	150	10294*
	1500	120 x 115 x 180	180	10295*
	2500	120 x 180 x 180	235	10296***
CUBE-Tank Outdoor Premium, for diesel incl. hinged lid, K33 analogue flow meter, cartridge filter with water separator, hose reel with 8m hose	1000	120 x 80 x 180	170	10297*
	1500	120 x 115 x 180	200	10298*
	2500	120 x 180 x 180	255	10299***
CUBE-Tank Extension I Indoor, for diesel comprises Indoor Basic package: with connection kit to first tank; excluding pump, hose, nozzle	NEW 1500	120 x 115 x 174	155	10776
	2500	120 x 180 x 174	210	10512
CUBE-Tank Extension I Outdoor, for diesel same as Extension I Indoor, incl. hinged lid	NEW 1500	120 x 115 x 180	170	10774
	2500	120 x 180 x 180	225	10300
CUBE-Tank Extension II Indoor: same as Extension I Indoor, only with connection to Exention II	NEW 1500	120 x 115 x 174	155	10777
	2500	120 x 180 x 174	210	10544
CUBE-Tank Extension II Outdoor: same as Extension II Indoor, incl. hinged lid	NEW 1500	120 x 115 x 180	170	10775
	2500	120 x 180 x 180	225	10545

* with electric pump 56 l/min *** with electric pump 72 l/min (pump output in free flow. Please note that the pump output can fall sharply depending on the length and cross-sectional area of the hose.)

Technical specifications subject to change.

CUBE-Diesel filling station [PG 4]



CUBE-Diesel filling station, 5,000l Outdoor Premium



Filling the CUBE-Tank systems is this easy



Delivery line with connection to first tank and switching valves included in scope of delivery of the expansion unit.

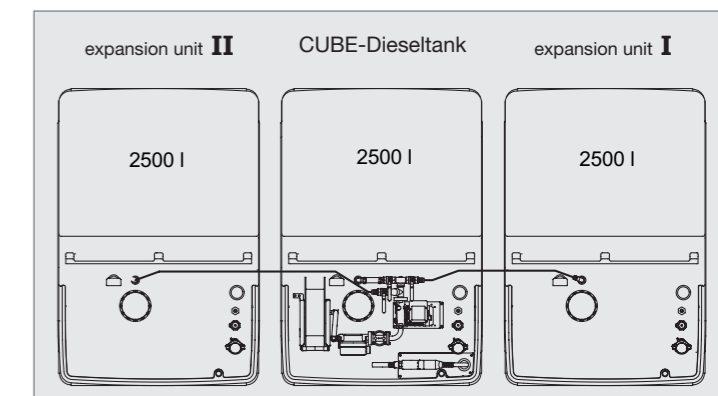

CUBE-Diesel filling station 7,500l with expansion unit I and II

CUBE-Diesel filling stations 5,000l and 7,500l

Designation	consisting of	Delivery rate l/min *	External Dimensions cm (w x d x h)	Weight approx. kg	Order No.
CUBE-Diesel filling station 5,000l Indoor Basic	CUBE-Diesel filling station Indoor Basic (10293) and CUBE expansion unit I Indoor (10512)	72	250 x 180 x 174	430	10525
CUBE-Diesel filling station 5,000l Outdoor Premium	CUBE-Diesel filling station Outdoor Premium (10299) and CUBE expansion unit I Outdoor (10300)	72	250 x 180 x 180	480	10379
CUBE-Diesel filling station 7,500l Indoor Basic	CUBE-Diesel filling station Indoor Basic (10293), CUBE expansion unit I Indoor (10512) and CUBE expansion unit II Indoor (10544)	72	380 x 180 x 174	640	10546
CUBE-Diesel filling station 7,500l Outdoor Premium	CUBE-Diesel filling station Outdoor Premium (10299), CUBE expansion unit I Outdoor (10300) and CUBE expansion unit II Outdoor (10545)	72	380 x 180 x 180	705	10547









Accessories see page 16.

* Pump output in free flow. Please note that the pump output can fall sharply depending on the length and cross-sectional area of the hose.

Technical specifications subject to change.

CUBE-Dieseltank [PG 4]

Accessories for CUBE-Dieseltank

Designation	Order No.
 Hose reel with 8 m hose DN 19	10375
 K33 meter, 3-digit tank display	10376
 Filter with water separator	10377
 K33 meter, complete with filter and water separator	10662
 Meter with access control and "CMO 10" tank data management system for up to 250 users, incl. 5 user keys and 1 master key	10745
 Data transfer set with 3 data transfer cards and USB key reader for wireless data transfer to PC, incl. PC software	10746
 Key set with 5 user keys	10747
 LED instrument lighting with motion sensor and battery	10378
 Hinged lid, orange, complete with supporting gas struts and mounting accessories	10324

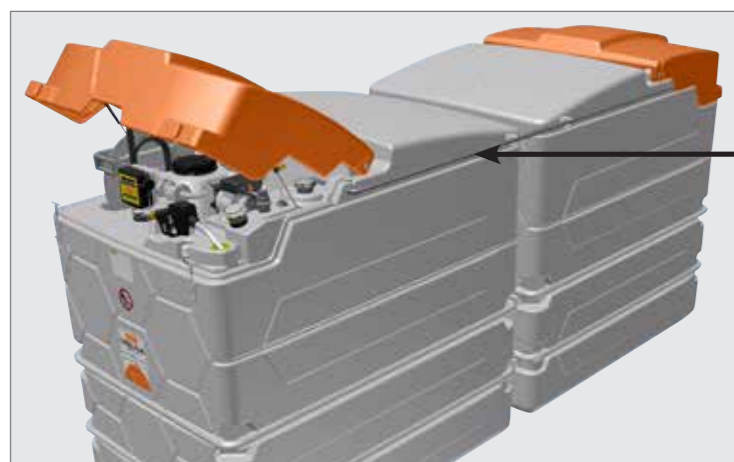

Accessory package for placement lengthwise

Accessory for CUBE-Diesel filling stations 5,000l

Bezeichnung	Best.-Nr.
Accessory package for placement lengthwise in connection of two CUBE-Dieseltanks 2,500 l with expansion unit I (see page 14) resp. CUBE-Diesel filling stations 5.000l (see page 15)	10666

Technical specifications subject to change.

CUBE-Dieseltank 2,500l Outdoor Premium Plus with tank data management system "CMO 10" [PG 4]

Dispensing station Outdoor Premium Plus with general construction inspection approval no. Z-40.21-510

- comprising integral sump
- optical bund alarm
- tanker coupling
- electronic overflow sensor
- vent
- analogue contents gauge
- suction hose
- electric pump 230V / 72 l/min*
- meter with access control and "CMO 10" tank data management system for up to 250 users
- incl. 5 user keys and 1 master key
- hose reel with 8m hose
- automatic nozzle with integral nozzle holder
- approved for outdoor installation with hinged lid (outdoor model)
- fully assembled



Meter with access control and "CMO 10" tank data management system for up to 250 users, incl. 5 user keys and 1 master key



CUBE-Dieseltank 2,500l Outdoor Premium Plus

Designation	Capacity l	Dimensions cm (l x w x h)	Weight approx. kg	Order no.
CUBE-Dieseltank Outdoor Premium Plus	NEU 1000	120 x 80 x 180	170	10780
	NEU 1500	120 x 115 x 180	200	10778
	2500	120 x 180 x 180	255	10736

* Pump output in free flow. Please note that the pump output can fall sharply depending on the length and cross-sectional area of the hose.

Technical specifications subject to change.