

COIL - TUBE Ø 13

18 W

- Wire insulation class.....H (>185°C)
- ED.....100%
- Coil power at 20° C.....18 W
- Ambient temperature.....-20 +40° C
- Weight.....0,15 Kg

ELECTRIC CIRCUITS

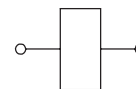

STANDARD

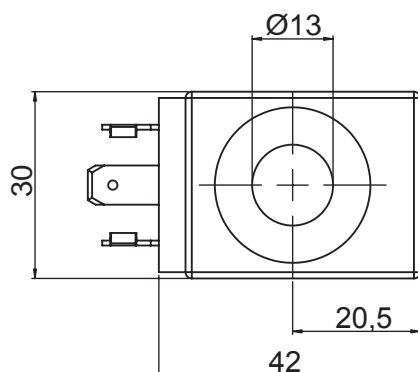
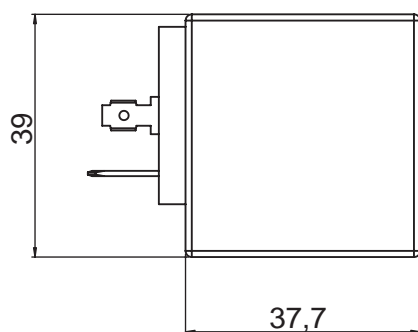

316

CONNECTOR	PROTECTION CLASS	COIL THERMAL INSULATION CLASS	VOLTAGE [V]	RESISTANCE [Ω]	CIRCUIT	ORDERING CODE
DIN 43650	IP65*	F	12 V dc	7,5	STANDARD	<b>093001131</b>
DIN 43650	IP65*	F	24 V dc	30,1	STANDARD	<b>093002131</b>
DIN 43650	IP65*	F	24 V rac**	25,6	STANDARD	<b>093007130</b>
KOSTAL M27x1	IP65*	F	12 V dc	7,5	STANDARD	<b>093401131</b>
KOSTAL M27x1	IP65*	F	24 V dc	30,1	STANDARD	<b>093402131</b>

\* Protection index with standard connector

\*\* Rectifier not included