

DESCRIPTION

Solenoid valve 3 way
direct acting poppet type

CONSTRUCTION

Body	Brass
Armature tube	Brass
Plunger and core	Stainless steel
Springs	Stainless steel
Seal material	NBR
	FPM
	EPDM



FEATURES

Maximum allowable pressure : maximum differential pressure +10%

Maximum fluid viscosity 25cSt (mm²/s)

Ambient temperature : with class F coil -10°C +55°C
with class H coil -10°C +80°C

Universal mounting position

- OPTIONS :** Stainless steel armature tube
Electroless nickel plating
Explosion proof coil according to ATEX - EExmII Series7
Exhaust port with hosetail connection

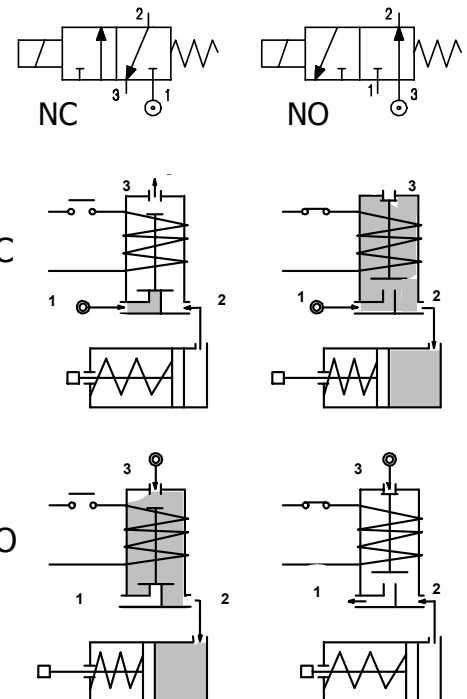

3

CODE ① ②	Connection G ISO 228	Orifice mm		KV m ³ /h	Differential pressure bar			Nominal power			Coil		Seal ①	Temp. range °C
		Inlet	Exh.		Min	Max		AC Inrush	VA Holding	DC Watt	Series	Width		
						AC	DC							
NC Normally closed														
E304A.....15///.....	1/8"	1.5	0.06	0	10	10	12	8	6.5	3	22	NBR=B EPDM=E FPM=V	-10 +90 <+140 -10 +130	
NO Normally open														
E304A.....15/S/.....	1/8"	1.5	0.06	0	10	10	12	8	6.5	3	22			

- ① Seal
② Coil

Example: E304AV15///30B FPM seal Coil 24V 50/60Hz NC
E304AB15/S/301 NBR seal Coil 24V DC NO

COILS	Alternating Current ~50/60Hz Volt							Direct Current Volt			Electrical connection	Connectors
	12	24	48	110	220 230	240	380	12	24	48		
Series 3 Width 22 Code ②	30A	30B	30C	30D	30E	30F	30G	300	301	302	DIN 46244	PG9 code 10348000

DESCRIPTION
 Class F insulation
 Voltage tolerance
 AC +15% -10%
 DC ± 10%
 Protection class
 IP65 with connector fitted
 IP00 without connector
 Continuous service ED100%

OPTIONS
 Class H insulation
 Cable attached
 Special coil voltages
 Special coil powers

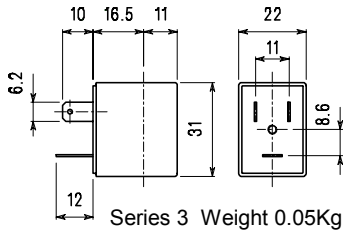

SPARE PARTS LIST

1. Coil fixing nut
2. Coil
3. Plunger
4. Armature tube with core

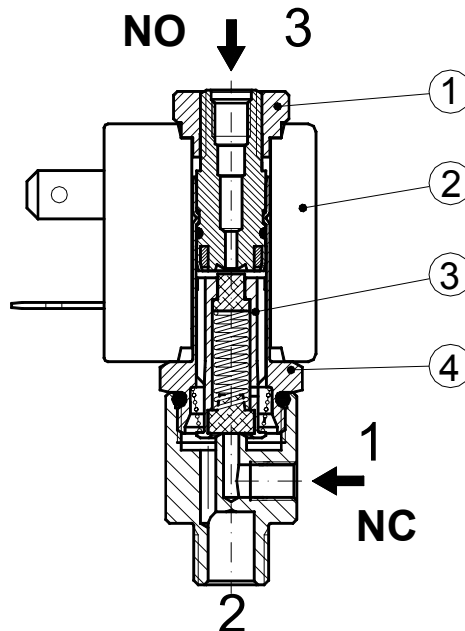

OVERALL DIMENSION

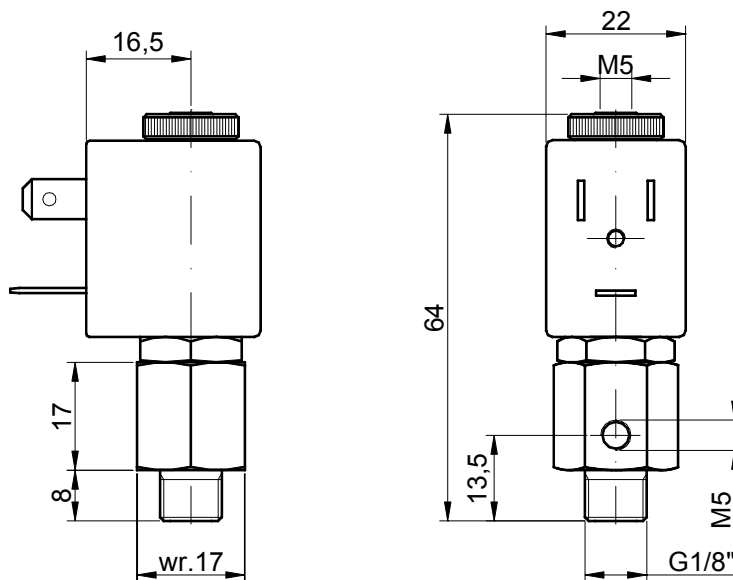

Weight = 0.11 Kg