



FUEL MANAGEMENT SYSTEMS



DISPENSERS



KITS



PUMPS



METERS



NOZZLES

# EX50 DRUM

## FEATURES

- STURDY STRUCTURE
- FLANGED COMPONENTS
- ANTI-NOISE FILTER
- THERMAL PROTECTION
- BUILT-IN BYPASS VALVE
- SUCTION PIPE WITH INTEGRATED FILTER
- UL LISTED VERSION AVAILABLE

The PIUSI EX50 DRUM is a complete pump transfer kit expressly engineered for ATEX/IECEx areas. This system is composed of a high-efficiency pump, manual or automatic nozzle and a telescopic suction hose. Thanks to the flanged components, this transfer set allows users to replace any component without using sealants thus creating maximum versatility and adaptability to any kind of condition. K33 mechanical meter available on request.



PIUSI EX50 DRUM WITH METER AND FILTER



### PERFORMANCE

UP TO  
**50 L/MIN**

FLOW RATE

**1100 MM**

SUCTION PIPE

**±1%**

ACCURACY

**200β/30μ**

FILTERING CAPACITY



EX50 DRUM WITH AUTOMATIC NOZZLE



EX50 DRUM WITH AUTOMATIC NOZZLE

OUR PUMPS COMPLIES WITH THE FOLLOWING MARKING ATEX/IECEx

II	2	G	Ex	d	IIA	T4	Gb
GROUP	CATEGORY	TYPE OF EXPLOSIVE ATMOSPHERE	PERMANENT PREFIX	PROTECTION METHOD	GAS GLASS	TEMPERATURE CLASS	EQUIPMENT PROTECTION LEVEL

### PACKAGING

CODE	WEIGHT		PACKAGING		
	KG	LBS	MM	INCH	PCS/BOX

#### WITHOUT METER

FO0372000	10	22	600X400X290	23,6X13,7X11,4	1
FO0372010	10	22	600X400X290	23,6X13,7X11,4	1
FO0372020	7,9	17,4	345X175X225	-	1
FO0372030	10	22	600X400X290	23,6X13,7X11,4	1
FO0372040	10	22	600X400X290	23,6X13,7X11,4	1
FO037400A	10	22	600X400X290	23,6X13,7X11,4	1
FO037401A	10	22	600X400X290	23,6X13,7X11,4	1
FO037402A	7,9	17,4	345X175X225	-	1

#### WITH METER

FO037500A	12	22	600X400X290	23,6X13,7X11,4	1
FO037501A	12	22	600X400X290	23,6X13,7X11,4	1
FO037502A	12	22	600X400X290	23,6X13,7X11,4	1
FO037503A	12	22	600X400X290	23,6X13,7X11,4	1
FO037600B	12	22	600X400X290	23,6X13,7X11,4	1
FO037601B	12	22	600X400X290	23,6X13,7X11,4	1



FILTRATION



TANK MONITORING



HOSE REEL



ACCESSORIES



MERCHANDISE



AIR



ANTIFREEZE



AdBlue®



BIODIESEL



DIESEL



FOOD



GASOLINE



GREASE



KEROSENE



OIL



WATER



WINDSCREEN

## CHART

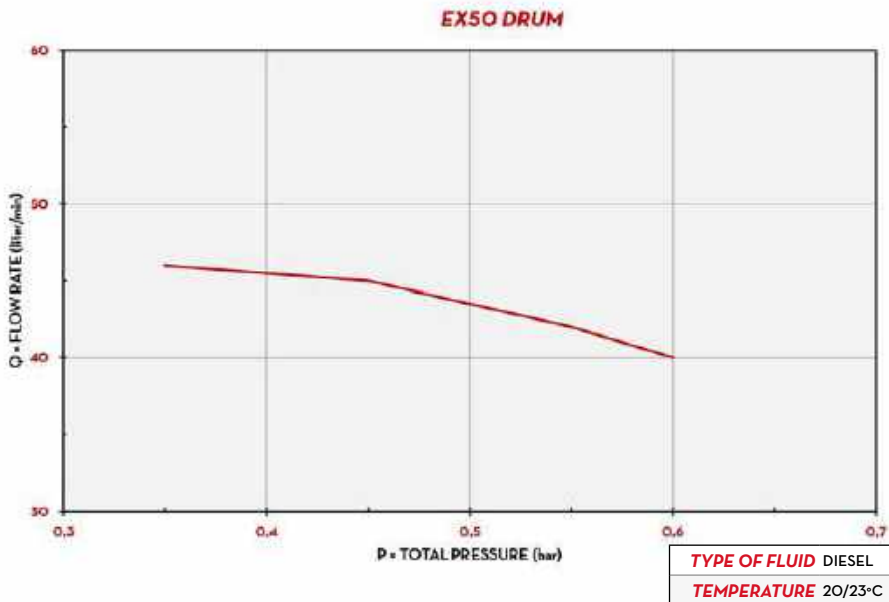

## DIMENSIONS

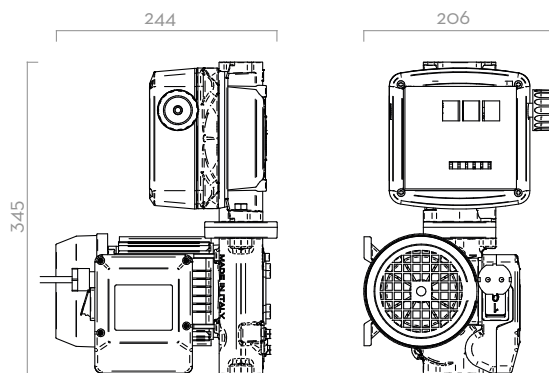

Dimensions expressed in millimeters

## IN THE BOX

- EX50 PUMP
- TELESCOPIC SUCTION PIPE
- DELIVERY HOSE
- WATER CAPTOR FILTER
- NOZZLE
- 2" CONNECTOR
- K33 MECHANICAL METER (ON REQUEST)
- INSTRUCTION MANUAL

## DETAILS



## COMPONENTS

- **PUMP:**  
EX50 PAG. 94
- **METER:**  
K33 ATEX PAG. 128
- **NOZZLE:**  
A60 ATEX PAG. 156  
SELF3000 PAG. 162
- **FILTER:**  
WATER CAPTOR PAG. 170

## TECHNICAL DATA

CODE	DESCRIPTION	FLUIDS TYPE	FLOW RATE		VOLTAGE			METER	NOZZLE	FILTER	INLET	HOSE	
			L/MIN	GPM	AC V/ HZ	DC VOLT	POWER WATT					AMP. MAX.	BSP
<b>WITHOUT METER</b>													
FO0372000	DRUM EX50 12V DC ATEX + MAN. NOZZLE	<span style="color: green;">D</span> <span style="color: red;">G</span> <span style="color: blue;">K</span>	50	13	12	250	21	-	SELF3000	YES	1"	4	3/4"
FO0372010	DRUM EX50 12V DC ATEX + AUT. NOZZLE	<span style="color: green;">D</span> <span style="color: red;">G</span> <span style="color: blue;">K</span>	50	13	12	250	21	-	A60	YES	1"	4	3/4"
FO0372020	KIT DRUM EX50 12V DC ATEX	<span style="color: green;">D</span> <span style="color: red;">G</span> <span style="color: blue;">K</span>	50	13	12	250	21	-	NO	NO	1"	-	-
FO0372030	DRUM EX50 12V DC ATEX + MAN. NOZZLE + CABLE	<span style="color: green;">D</span> <span style="color: red;">G</span> <span style="color: blue;">K</span>	50	13	12	250	21	-	SELF3000	YES	1"	4	3/4"
FO0372040	DRUM EX50 12V DC ATEX + AUT. NOZZLE + CABLE	<span style="color: green;">D</span> <span style="color: red;">G</span> <span style="color: blue;">K</span>	50	13	12	250	21	-	A60	YES	1"	4	3/4"
FO037400A	DRUM EX50 230V ATEX + MAN. NOZZLE	<span style="color: green;">D</span> <span style="color: red;">G</span> <span style="color: blue;">K</span>	50	13	230/50-60	250	1	-	SELF3000	YES	1"	4	3/4"
FO037401A	DRUM EX50 230V ATEX + AUT. NOZZLE	<span style="color: green;">D</span> <span style="color: red;">G</span> <span style="color: blue;">K</span>	50	13	230/50-60	250	1	-	A60	YES	1"	4	3/4"
FO037402A	KIT DRUM EX50 230V ATEX	<span style="color: green;">D</span> <span style="color: red;">G</span> <span style="color: blue;">K</span>	50	13	230/50-60	250	1	-	NO	NO	1"	-	-
<b>WITH METER</b>													
FO037500A	DRUM EX50 12V DC K33 ATEX + MAN. NOZZLE	<span style="color: green;">D</span> <span style="color: red;">G</span> <span style="color: blue;">K</span>	50	13	12	250	21	K33	SELF3000	YES	1"	4	3/4"
FO037501A	DRUM EX50 12V DC K33 ATEX + AUT. NOZZLE	<span style="color: green;">D</span> <span style="color: red;">G</span> <span style="color: blue;">K</span>	50	13	12	250	21	K33	A60	YES	1"	4	3/4"
FO037502A	DRUM EX50 12V DC K33 ATEX + MAN. NOZZLE + CABLE	<span style="color: green;">D</span> <span style="color: red;">G</span> <span style="color: blue;">K</span>	50	13	12	250	21	K33	SELF3000	YES	1"	4	3/4"
FO037503A	DRUM EX50 12V DC K33 ATEX + AUT. NOZZLE + CABLE	<span style="color: green;">D</span> <span style="color: red;">G</span> <span style="color: blue;">K</span>	50	13	12	250	21	K33	A60	YES	1"	4	3/4"
FO037600B	DRUM EX50 230V K33 ATEX + MAN. NOZZLE	<span style="color: green;">D</span> <span style="color: red;">G</span> <span style="color: blue;">K</span>	50	13	230/50-60	250	1	K33	SELF3000	YES	1"	4	3/4"
FO037601B	DRUM EX50 230V K33 ATEX + AUT. NOZZLE	<span style="color: green;">D</span> <span style="color: red;">G</span> <span style="color: blue;">K</span>	50	13	230/50-60	250	1	K33	A60	YES	1"	4	3/4"

( ) UPON REQUEST IT IS AVAILABLE WITH DIFFERENT VOLTAGES AND 60 HZ FREQUENCY. COMPATIBLE FLUIDS: DIESEL, KEROSENE, PETROL, PETROL ALCOHOL MIXED MAX 15%, AVGAS 100/100LL (ONLY PUMP&METER), JET A/A1 (ONLY PUMP&METER), ASPEN 2/4

## EX50 DRUM