

ACCESSORIES FOR GREASE PUMPS

Follower plate for pumps S. 600 - 700 with suction tube \varnothing 30

union \varnothing 30 mm



P/N OE66265

Follower plate \varnothing 265 mm ▶ drum internal \varnothing 240 - 260 mm

P/N OE66310

Follower plate \varnothing 310 mm ▶ drum internal \varnothing 255 - 300 mm

P/N OE66340

Follower plate \varnothing 340 mm ▶ drum internal \varnothing 300 - 330 mm

P/N OE66370

Follower plate \varnothing 370 mm ▶ drum internal \varnothing 335 - 360 mm

P/N OE66400

Follower plate \varnothing 400 mm ▶ drum internal \varnothing 360 - 400 mm

P/N OE66590

Follower plate \varnothing 585 mm ▶ drum internal \varnothing 540 - 580 mm

union \varnothing 45 mm

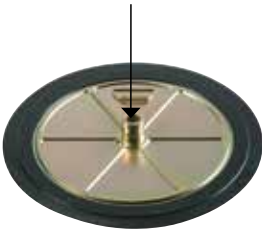

Follower plate for pumps S. 900 - 1200 with suction tube \varnothing 45

P/N OE10/60

Follower plate \varnothing 585 mm ▶ drum internal \varnothing 540 - 580 mm

P/N OE10/61

Follower plate \varnothing 400 mm ▶ drum internal \varnothing 360 - 400 mm

P/N OE10/62

Follower plate \varnothing 370 mm ▶ drum internal \varnothing 335 - 360 mm

union \varnothing 50,8 mm

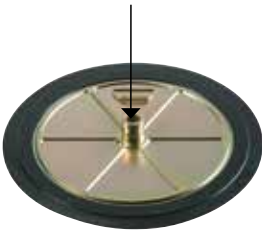

Follower plate for pumps S. 1200 - 1500 with suction tube \varnothing 50,8

P/N OE10/65

Follower plate \varnothing 585 mm ▶ drum internal \varnothing 540 - 580 mm

P/N OE10/66

Follower plate \varnothing 400 mm ▶ drum internal \varnothing 360 - 400 mm

P/N OE10/67

Follower plate \varnothing 370 mm ▶ drum internal \varnothing 335 - 360 mm

HOW THE FOLLOWER PLATE WORKS

The **follower plate** is always recommended but becomes indispensable when using particularly hard greases. The follower plate is pulled towards the bottom of the drum by the vacuum created by the pump and always ensures the following advantages:

- 1** it compresses the grease, preventing air pockets from forming and possible cavitation of the pump
- 2** it keeps the grease clean, as well as preserving its characteristics
- 3** it enables collection of all the grease from the bottom of the drum, that would otherwise remain stuck to the sides

The atmospheric pressure at sea-level is 1 bar, equivalent to approx. 1 kg per cm². When the pump sucks the grease from the container, a vacuum is created under the follower plate and, at the same time, depending on the width of its surface, a pressure from 370 kg to 2000 kg is created above it.

WITHOUT FOLLOWER PLATE

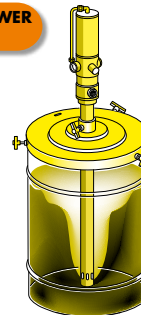

WITH FOLLOWER PLATE

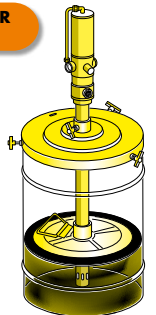

Pump

Drum cover

Follower plate

Vacuum created by pump sucking the grease

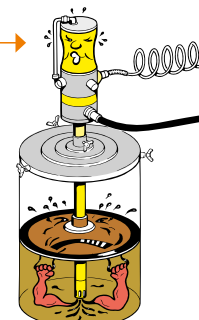

ACCESSORIES FOR GREASE PUMPS

Drum cover for manual pumps with suction tube \varnothing 25 - 30 - 38

P/N OE65309

Drum cover \varnothing 337 mm

- ▶ drums external \varnothing 270 - 330 mm
for P/N OE60311 (suction tube \varnothing 25 mm)

P/N OE65311

Drum cover \varnothing 337 mm

- ▶ drums external \varnothing 270 - 330 mm
for P/N OE60411 (suction tube \varnothing 38 mm)

P/N OE65312

Drum cover \varnothing 337 mm

- ▶ drums external \varnothing 270 - 330 mm
for pumps with \varnothing 30 mm suction tube

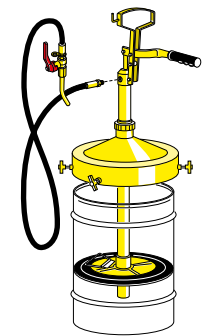
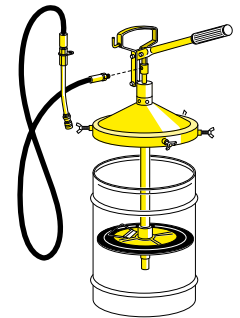

union \varnothing 25 - 30 - 38 mm

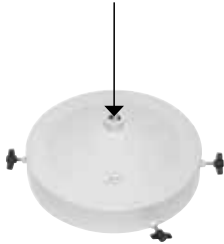

Drum cover for pumps S. 600 - 700 with suction tube \varnothing 30

P/N OE65280

Drum cover \varnothing 280 mm

- ▶ drums external \varnothing 240 - 280 mm

P/N OE65310

Drum cover \varnothing 310 mm

- ▶ drums external \varnothing 260 - 300 mm

P/N OE65350

Drum cover \varnothing 350 mm

- ▶ drums external \varnothing 300 - 350 mm

P/N OE65385

Drum cover \varnothing 385 mm

- ▶ drums external \varnothing 340 - 385 mm

P/N OE65420

Drum cover \varnothing 420 mm

- ▶ drums external \varnothing 370 - 420 mm

P/N OE65600

Drum cover \varnothing 600 mm

- ▶ drums external \varnothing 550 - 600 mm

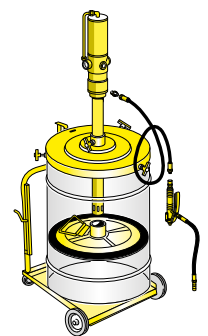

union \varnothing 30 mm



ACCESSORIES FOR GREASE PUMPS

Drum cover for pumps with suction tube \varnothing 45



P/N OE10/50

Drum cover \varnothing 600 mm

▶ drums external \varnothing 550 - 600 mm

P/N OE10/51

Drum cover \varnothing 420 mm

▶ drums external \varnothing 370 - 420 mm

P/N OE10/52

Drum cover \varnothing 385 mm

▶ drums external \varnothing 340 - 385 mm

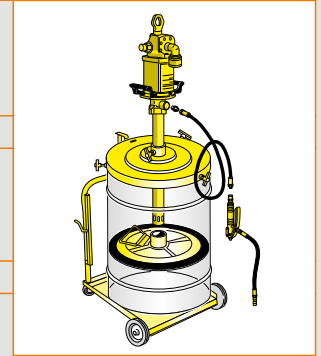

Drum cover for pumps with suction tube \varnothing 50,8



P/N OE10/55

Drum cover \varnothing 600 mm

▶ drums external \varnothing 550 - 600 mm

P/N OE10/56

Drum cover \varnothing 420 mm

▶ drums external \varnothing 370 - 420 mm

P/N OE10/57

Drum cover \varnothing 385 mm

▶ drums external \varnothing 340 - 385 mm

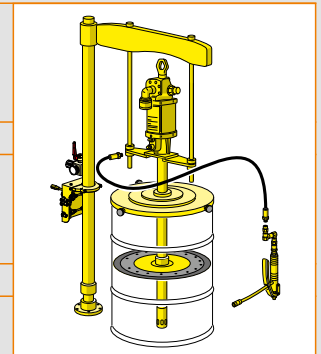

Drum cover with 2" F union suitable for standard bung adaptor

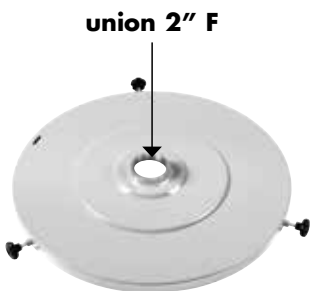

P/N OE65160

Drum cover \varnothing 600 mm

▶ drums external \varnothing 550 - 600 mm

P/N OE65142

Drum cover \varnothing 420 mm

▶ drums external \varnothing 370 - 420 mm

P/N OE65138

Drum cover \varnothing 385 mm

▶ drums external \varnothing 340 - 385 mm

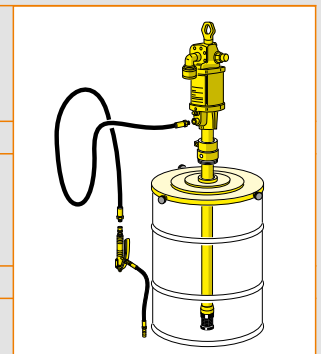

P/N OE66599

Handle for portable grease kit supplied with grease kits P/N OE64021 - P/N OE64031