

GROUNDING REEL

Grounding reel satisfies the need to ground fuel tanks during transferring operation in order to discharge electric charges.



II (3) 3 GD
II (3) 2/3 GD



APPLICATIONS:

tanks and oil-refinery, aviation, tank truck, boating.



Operation:

Before begin fuel transfer operator must connect the grounding clamp, mounted at the end of the cable, to the grounding plate which is compulsory on every tank truck (Pic. A). As an alternative the grounding reel may be installed on the tank truck and the clamp connected to the grounding plate (Pic. B). Grounding reel must be installed in a safe zone (potentially not dangerous) since it is not provided with Atex Certification. Antiexplosive clamp, standard on some models below listed, may be installed in a potential explosive area (Zone 1) as specified in the CE declaration.

Pic. A

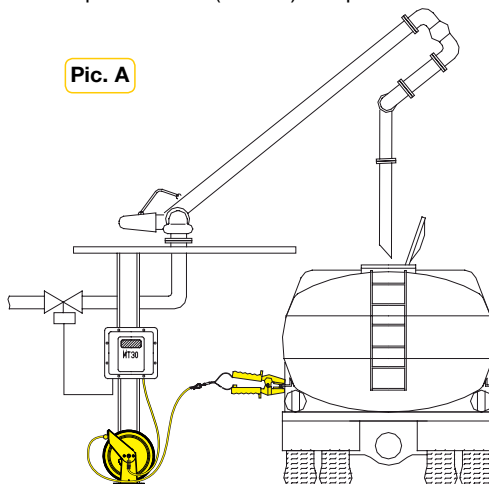

Pic. B

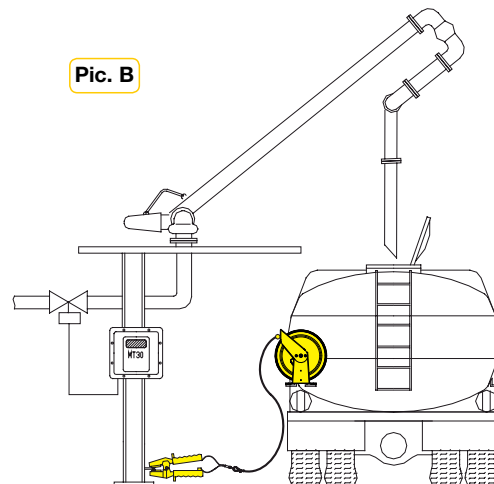

Article	Cable material	Insulation	Cable cross section	Cable length	Grounding clamp
OE7535000	without cable	max cable capacity 30 m - cross section 16 mm ²			
OE735131/60141	copper	PUR	6 mm ²	14,5 m	antiexplosive 10A
OE735131/60261	copper	PUR	6 mm ²	26 m	antiexplosive 10A
OE735131/60152	copper	PUR	6 mm ²	15 m	standard 50A
OE735131/60252	copper	PUR	6 mm ²	25 m	standard 50A
OE735141/60152	steel	PVC	7x7 ø 5 mm	15 m	standard 50A
OE735141/60252	steel	PVC	7x7 ø 5 mm	25 m	standard 50A

OVERALL DIMENSIONS

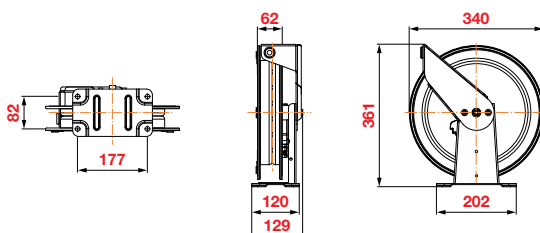

☐ N°1 packing m³ 0,045 ⚖ from kg 10,3 to 11,5

Art. OE7535111
Standard grounding clamp 100A

