

12V DC	F04-12L8201-03S F04-12L8201-03B	Suction-Aspirante Blowing-Soffiante							
Test Voltage: 13,0 VOLT DC									
Static Pressure	SUCTION Aspirante				BLOWING Soffiante				
Pa	IN H2O	Airflow m ³ /h	Airflow cfm/h	Current A	Eff. %	Airflow m ³ /h	Airflow cfm/h	Current A	Eff. %
0	0	2710	1600	19,9	0,0	2720	1600	17,5	0,0
50	0,2	2490	1470	20,7	12,9	2520	1490	18,7	14,4
100	0,4	2260	1330	21,4	22,6	2270	1340	19,6	24,7
150	0,6	2010	1190	22,1	29,2	1920	1130	20,3	30,3
200	0,8	1630	960	22,0	31,7	1470	870	21,6	29,1
250	1,0	1160	680	21,8	28,4	1140	670	22,1	27,6
300	1,2	880	520	22,5	25,1	830	490	22,2	24,0
350	1,4	630	370	23,1	20,4	560	330	22,7	18,4
400	1,6	390	230	23,7	14,1	330	190	23,6	12,0
450	1,8	130	80	24,3	5,1	140	80	24,9	5,4
500	2,0	0	0	26,1	0,0	0	0	24,6	0,0

24V DC	F04-24L8201-03S F04-24L8201-03B	Suction-Aspirante Blowing-Soffiante							
Test Voltage: 26,0 VOLT DC									
Static Pressure	SUCTION Aspirante				BLOWING Soffiante				
Pa	IN H2O	Airflow m ³ /h	Airflow cfm/h	Current A	Eff. %	Airflow m ³ /h	Airflow cfm/h	Current A	Eff. %
0	0	2720	1600	9,6	0,0	2760	1630	9,2	0,0
50	0,2	2520	1490	10,0	13,5	2540	1500	9,6	14,1
100	0,4	2290	1350	10,3	23,8	2300	1360	10,0	24,6
150	0,6	2030	1200	10,6	30,7	1940	1140	10,3	30,2
200	0,8	1660	980	10,6	33,5	1440	850	10,7	28,8
250	1,0	1200	710	10,6	30,2	1150	680	11,0	27,9
300	1,2	890	530	10,9	26,2	830	490	11,1	24,0
350	1,4	640	380	11,2	21,4	550	320	11,2	18,4
400	1,6	430	250	11,5	16,0	320	190	11,5	11,9
450	1,8	200	120	11,9	8,1	130	80	12,2	5,1
500	2,0	0	0	12,5	0,0	0	0	12,8	0,0

ErP 2015 (2011/327/EC)
RENDIMENTO - EFFICIENCY

type	Pa	m3/h	A	kW	rpm	EFF.	r
Suction	200	1630	22,0	0,29	2980	31,7%	1,0022
Blowing	150	1920	20,3	0,26	2990	30,3%	1,0018

ErP 2015 (2011/327/EC)
RENDIMENTO - EFFICIENCY

type	Pa	m3/h	A	kW	rpm	EFF.	r
Suction	200	1660	10,6	0,28	3010	33,5%	1,0022
Blowing	150	1940	10,3	0,27	3030	30,2%	1,0018

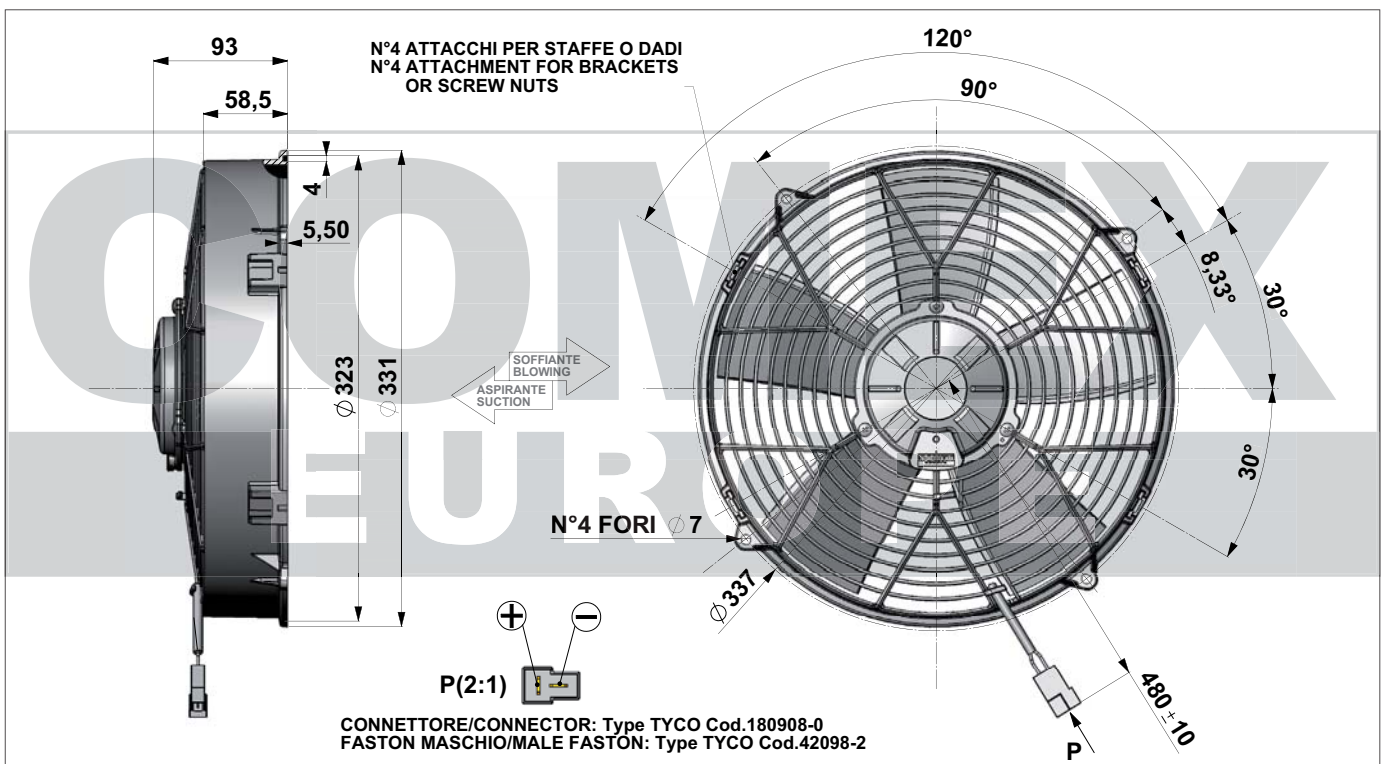

Weight: 2,6 Kg	Noise: LOW NOISE
Pressure rate: 1Pa = 0,004 inch H2O	Static Pressure: pascal (Pa)
Dimensions rate: 25,4 mm = 1 inch	Airflow rate: 1 m ³ /h = 0,59 cfm/h