

Technical features

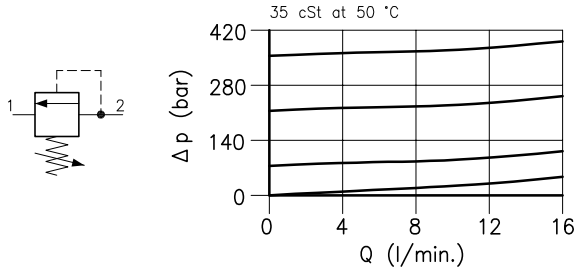

Cavity (For dimensions see catalogue 17.000)	S 20/2
Max. flow (l/min.)	12
Max. inlet pressure (bar)	420
Max. pressure on line 1 (bar)	210
Fluid viscosity range (cSt)	2.8 - 380
Fluid temperature range (°C)	-20 +80
Mass (kg)	0.075
Cracking pressure 95% of setting value	
Reseat pressure 90% of setting value	
Cracking pressure defined with 1 l/min.	
Standard setting obtained with 5 l/min.	
Hydraulic fluid; mineral oil HM and HV ISO 6074	
Recommended filtration; 19/15 ISO 4466 (25 μ absolutes)	
Standard seals in Polyurethane and Buna N	

Dimensions

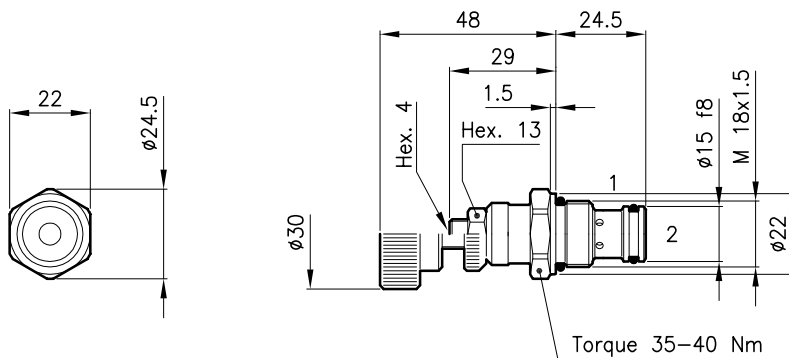

Ordering informations

LPS 20/20-D-N

LPS 20 = Valve type



Standard springs

Type	Setting range	Factory set
D	= 7 - 210 bar	140 bar
Q	= 105 - 420 bar	315 bar

Adjustment type

N = Standard adjustment

V = Handknob adjustment

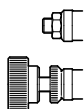

Codes:

LPS 20/20-D-N	21 011 102
LPS 20/20-Q-N	21 011 103
LPS 20/20-D-V	21 011 100
LPS 20/20-Q-V	21 011 101
External seals kit	90 620 100

LPS 20/20 valves can be assembled on standard bodies 20-LO series; for dimensions see catalogue 16.010