

# 2 WAY FLOW DIVIDER - Spool size 20

- Up to 450 bar [6527 psi]
- Up to 150 l/min [39.6 gpm]
- Direct in-line mounting, depending on system configuration
- Threaded connections :
  - ISO 1179 (BSPP/Gas)
  - ISO 11926 (UNF)
- Open or closed loop circuits
- Can work by dividing or combining the flow



*Specifications are subject to change without notice.*

## ▷ DESCRIPTION

FLUID-SYSTEM is a leader in the design of anti-slipping system (registered patent) for hydrostatic transmissions and will put its experience to work for you.

The flow divider is a slip preventing system for all types of hydrostatic transmissions. It provides 100%, on demand traction for any field configuration.

**FLUID-SYSTEM's flow divider is designed to suit the highest of performance and safety standards for all of our clients.**

The bidirectional flow divider controls the speed between wheels of the same axle, or between different axles by dividing or combining the flow. It is equipped with an electric or hydraulic controlled bypass that enables a higher operating speed on the road. It can be equally used on open or closed loop circuits.

FLUID-SYSTEM flow divider versatility allows for different installation options on many types of hydrostatic transmissions.

▷ **BENEFITS**

- Designed to reduce the installation and operation costs
- Robust and reliable
- No need for maintenance: cost savings and reduced risk of equipment failure
- Cost-effective solution
- Flows can be added or divided with precision
- Flow ratio can be adjusted to customer need
- Large range of options
- Long life span
- Rigorously designed; bench and field tested

▷ **HYDRAULIC SCHEMATIC**

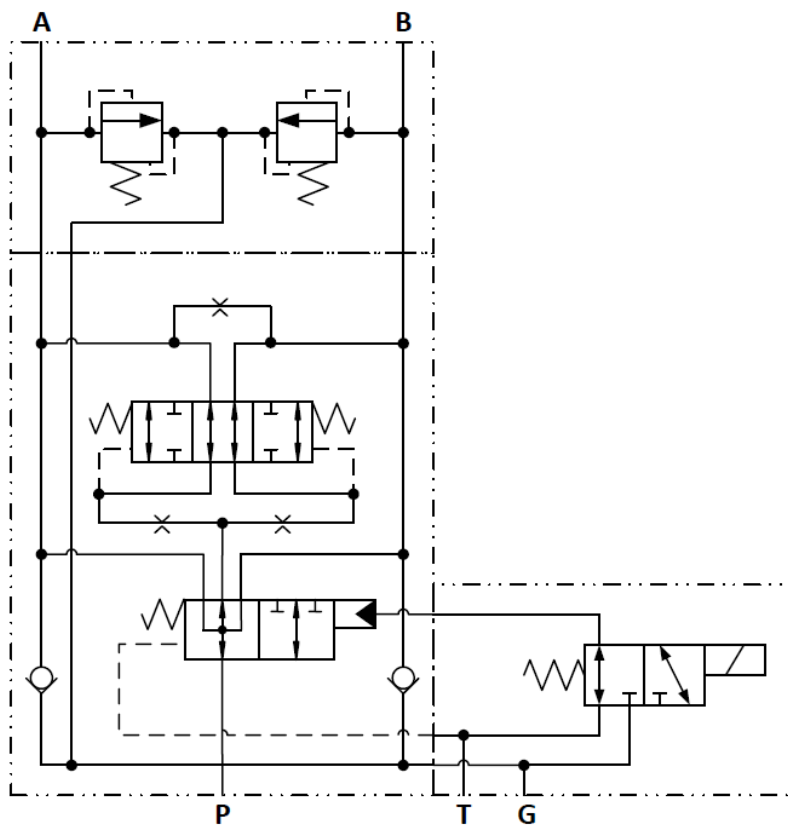

▷ OVERALL DIMENSIONS

Millimeter (Inches)

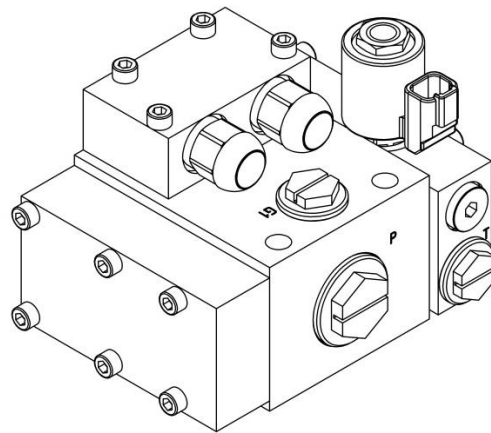
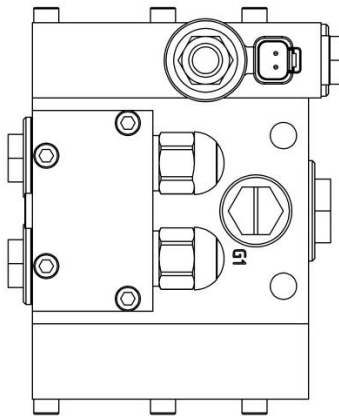
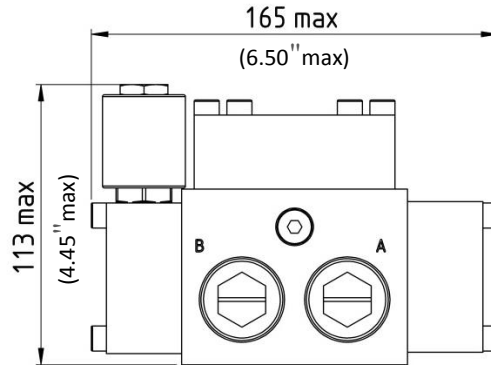
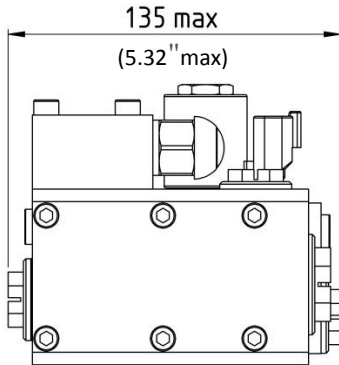

Can be found in many configurations:

- 1 solenoid valve (as shown above)
  - 2 solenoid valves
  - 3 solenoid valves
  - 4 solenoid valves
- } (by special request)

Each additional solenoid valve added after the first one enables the control of other functions like a feeding pump, a brake, a speed control, a selector, etc...

To obtain a specialized configuration technical specifications sheet, please contact our team.

▷ **INSTALLATION WARNING**

If you need to install a flushing valve in a closed loop circuit equipped with a flow divider, the flushing valve must be installed between the pump and the flow divider.

▷ **TECNICAL SPECIFICATIONS**

<b>Maximum Flow</b>	150 l/min (39.6 gpm)
<b>Operating Pressure</b>	450 bar (6527 psi)
<b>Piloting Pressure</b>	Min 8 bar (116 psi) - Max 50 bar (725 psi) *
<b>Maximum Pressure</b>	500 bar (7255 psi)
<b>Operating Temperature</b>	-20°C to 80°C (32°F to 176°F)
<b>Seals</b>	NBR **
<b>Threaded Connections</b>	ISO 1179 (BSP/Gas) - ISO 11926 (UNF)
<b>Weight</b>	8.9 kg (19.6 lbs)
<b>Material</b>	Steel
<b>Viscosity</b>	Between 10 and 100 cst
<b>Pollution Level</b>	20/18/15 as per ISO 4406
<b>Surface Treatment</b>	Phosphatation

\* Values can be changed upon request to our engineering department.

\*\* Other seals available on demand.

▷ PORT TABLE

Size	Max Flow	Ports	European Threads Connections ISO 1179-1	US Threaded Connections ISO 11926-1	Protective Cap
20	150 l/min	T – G1	3/8" BSP	3/4" - 16 UNF- 2B	Plastic
		A, B	1/2" BSP	7/8" - 14 UNF- 2B	Plastic
		P	3/4" BSP	1 1/16" - 12 UNF-2B	Plastic

▷ SPECIFICATION CURVES

a. DIVISION SPECIFICATIONS

Division ratio can be : 50/50 – 70/30 – 80/20

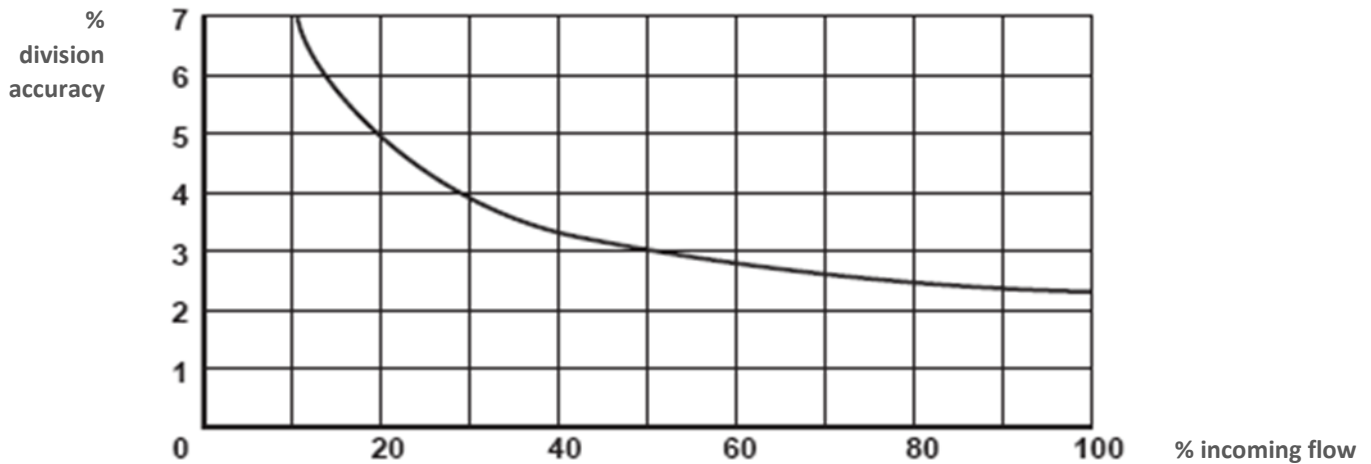

The precision is determined by the pressure difference of 150 bar (2176 psi) between A and B, without orifice and with a ratio of 50/50; it is equal to:

$$\frac{Q_A}{Q_P} \quad \text{ou} \quad \frac{Q_B}{Q_P}$$

### b. PRESSURE DROP

Bypass mode

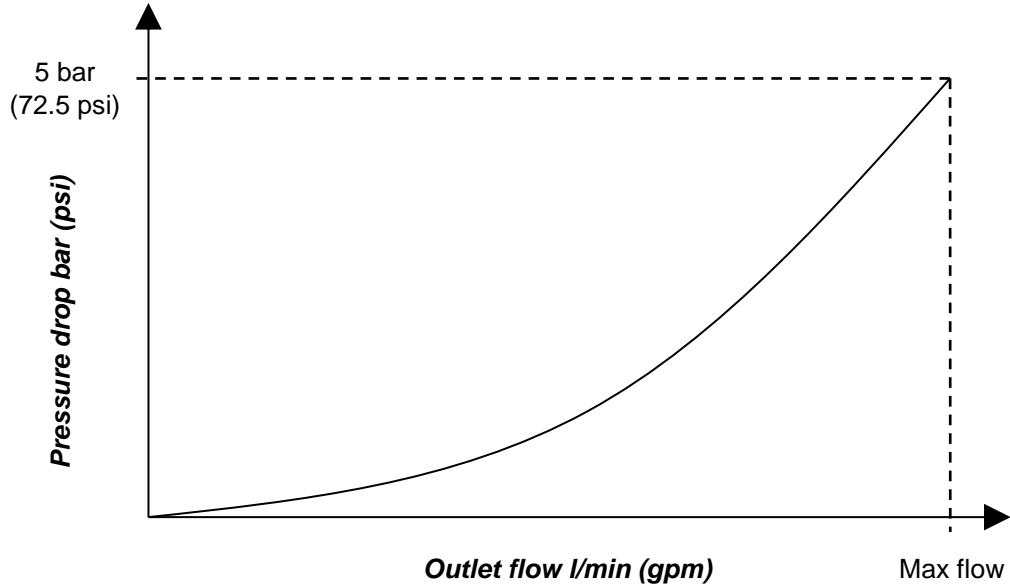

Division mode

The total pressure drop corresponds to the loss at the transfer restrictor boundaries increased by the loss of the block itself.

Test conditions: HV 46 hydraulic fluid at 40°C [104°F]

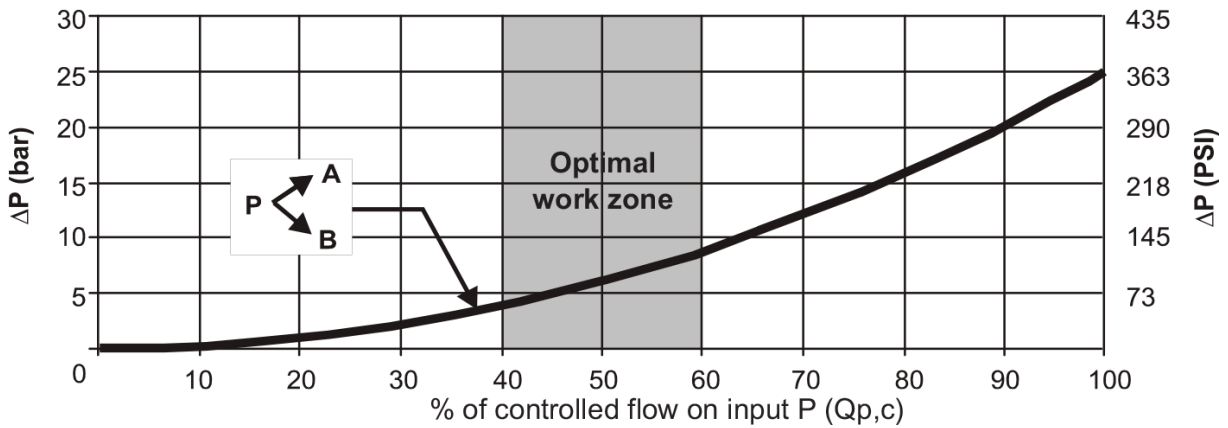

c. TRANSFER RESTRICTOR (with orifice size)

It is located between the two outlets.

Transfer restrictor calculation:

$$Q = 90 \times C \times S \times \sqrt{Dp}$$

↑ I /min     
 ↑ Restrictor shape (0.65 – 1.5)     
 ↑ cm<sup>2</sup>     
 ↑ bar

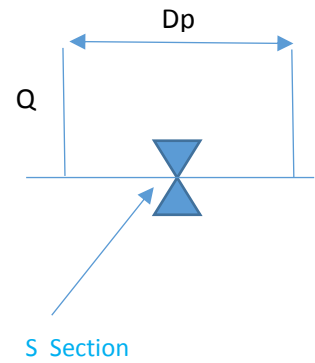

d. CHECK VALVES ON FEEDING SYSTEM

In some applications, a receiver located in front of the flow divider can use a higher flow than the one supplied. In this case, the oil is brought back in the line in order to protect the components from cavitation.

When a vehicle equipped with a hydrostatic transmission takes a turn, the external wheel must turn faster than the interior one. If the divider is installed between the right and the left wheels and is activated (without the bypass mode) while taking the turn, the check valves on the feeding system can be useful.

Note: Trials will confirm the required sizing for the application.

Nominal flow is around 40 l/min (10.6 US gpm) with a loss not exceeding 6 bar (87 psi).

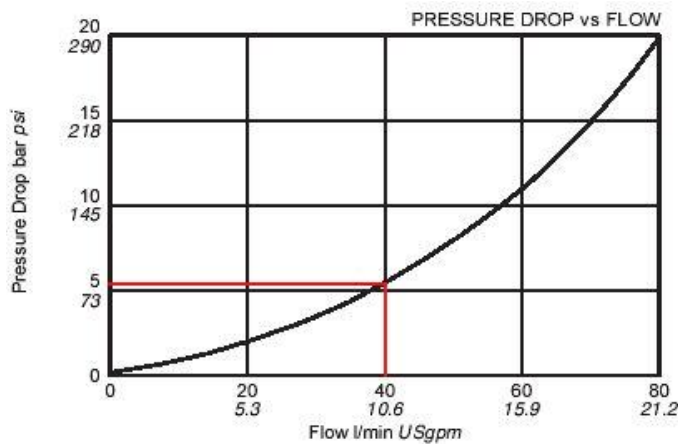

▷ PRODUCT CODE

1 2 3 4 5 6 7 8 9 10 11 12 13  
 D B - [ ] [ ] - [ ] [ ] - [ ] [ ] - [ ] [ ] [ ] [ ] - [ ] [ ] [ ] [ ] - [ ] [ ] - [ ] [ ] - [ ] [ ] - [ ] [ ] - [ ] [ ] - [ ] [ ] - [ ] [ ] [ ] [ ]

Function (1)	
DB	Flow divider

Operation way (2)	
DE	Bidirectional

No. of branches (3)	
1	
2	2X
3	
4	

Max flow (4)	
Size	Max Flow*
20	200
28	300
XX	Upon request

Divided flow** (5)	
010	10 l/min
020	20 l/min
040	40 l/min
080	80 l/min
150	150 l/min
xxx	Upon request

Division ratio (6)	
50 - 50	
70 - 30	
80 - 20	
60 - 40	
75 - 25	
55 - 45	
XX - YY (upon request)	

Transfer restrictor (7) from A to B	
00	Without
06	0,6 mm (0.024 in)
08	0,8 mm (0.031 in)
10	1 mm (0.039 in)
XX	Upon request

Branch protection HP (8)	
00	without
30	300 bar (4353 psi)
38	380 bar (5514 psi)
42	420 bar (6094 psi)
XX	Upon request

By pass (9)	
01	Hydraulic
02	Electrical 12V
03	Electrical 24V
XX	Upon request

Accessories (10)	
00	without
01	1 accessory
02	2 accessories
03	3 accessories
XX	Upon request

Supply Voltage (11)	
NN	Without
12	12 V
24	24 V
XX	Upon request

Connection (12)	
01	Standard UNF
02	BSP option
XX	Upon request

Special design (13)	
NNN	Sans

\* in by-pass mode

\*\* Flow for which division ratio is optimum



▷ APPLICATIONS

WITH HYDRAULIC CONTROL	WITH ELECTROHYDRAULIC CONTROL
<ul style="list-style-type: none"> <li>→ Excavation machinery</li> <li>→ Paved road sweepers</li> <li>→ Forestry equipment</li> <li>→ Harvesting machinery</li> </ul>	<ul style="list-style-type: none"> <li>→ Agricultural machinery</li> <li>→ Self-propelled mowers</li> <li>→ Lifting cranes</li> </ul>

Transmission circuit examples (Flow divider with integrated pressure supply valves)

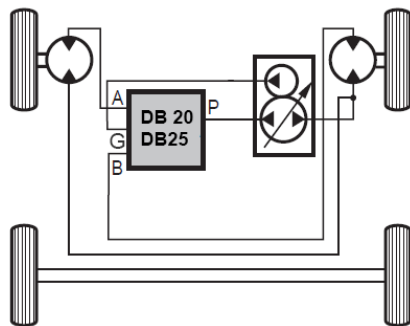

Flow divider operating as a wheel separator (Pst) with integrated pressure supply valves and supply port (S).

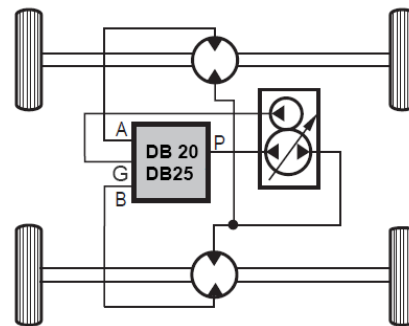

Flow divider operating as an axis separator with integrated pressure supply valves and supply port (S).

**Note:** If you need to install a flushing valve in a closed loop circuit equipped with a flow divider, the flushing valve must be installed between the pump and the flow divider. If necessary please consult us.

▷ ACCESSORIES

With electric controls, direct-acting, with spool valve, hydraulic screw distributor...