

This drawing is property of Hydraulfunktion AB and is loaned subject to return upon demand. It is not to be reproduced or used directly or indirectly in any way detrimental to the interest of Hydraulfunktion AB.

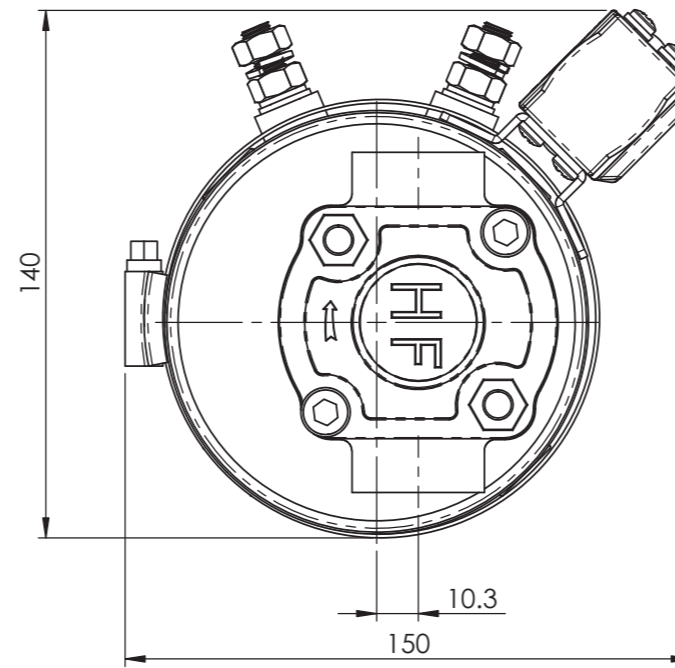
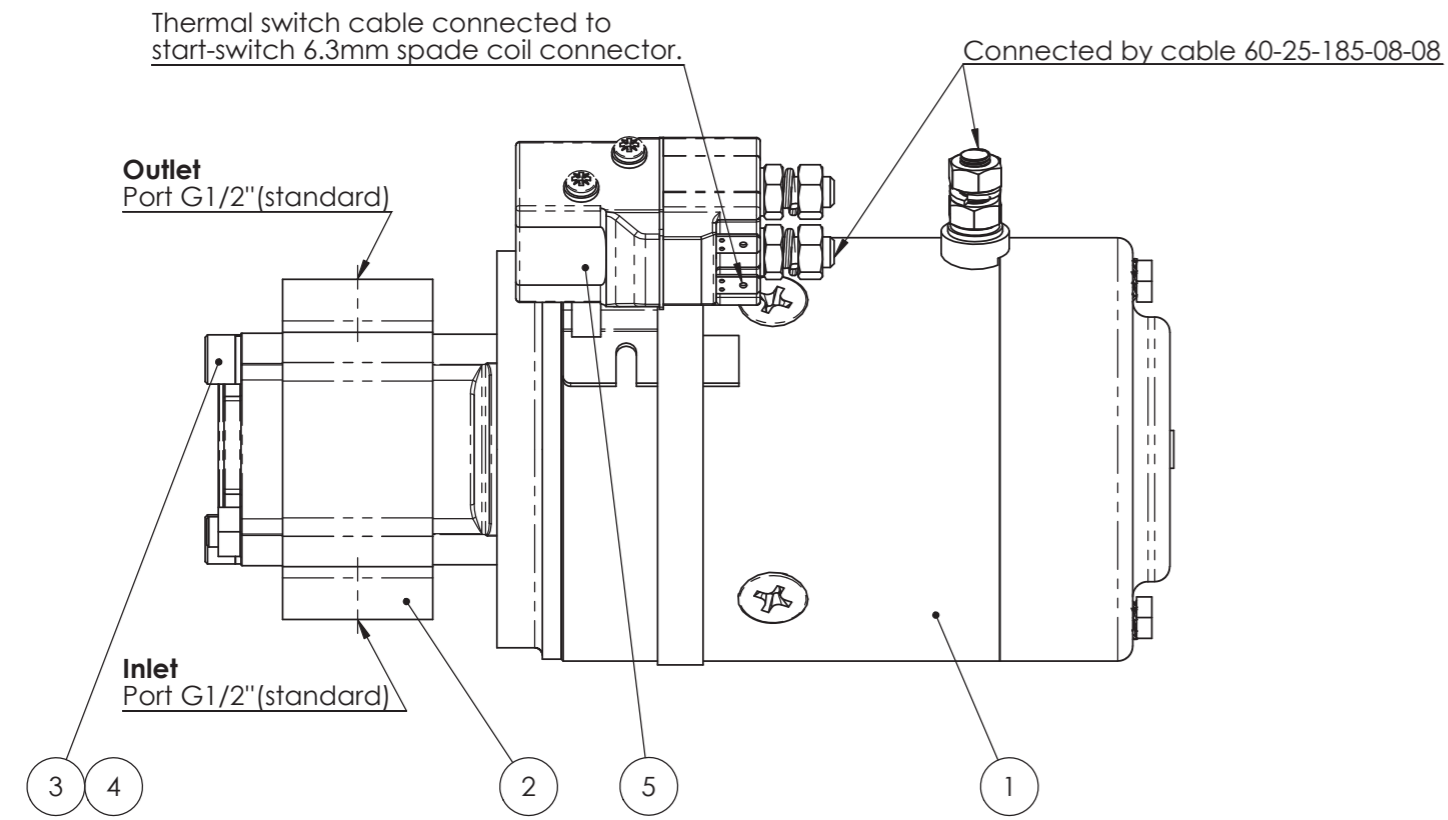

The DC motor is of S2/S3 duty, which can only be worked intermittently.

The dc motor and the solenoid valve should be activated simultaneously. It is forbidden to run the motor alone.

Check the oil level in the tank after the first start of the power unit and filling of the application.

Change the oil after the first 100 hours of using the power unit, then change the oil every 3000 hours.

Hydraulic Fluid: use only ISO 6743/4 (DIN 51519) mineral base fluids, new and filtered before use (25µ).

Voltage	Pos.1 (motor) Part nr.	Pos.5 (Start Switch) Part nr.
12V	1012-2	3512
24V	1024-2	3524
48V	1048-2	3748

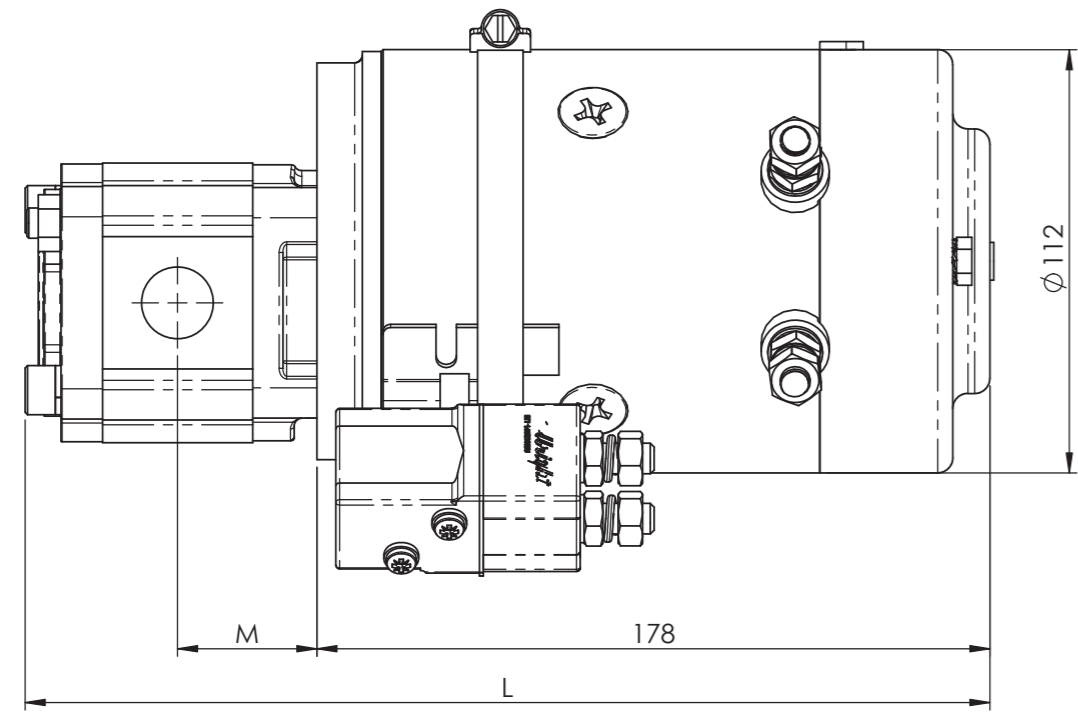

Pos.2 (Pump) part nr.	code	specification	flow at 180 bar (l/m)*			flow at 120 bar (l/m)*			Pos.3 (Screw) Part nr.	L	M
			12V motor	24V motor	48V motor	12V motor	24V motor	48V motor			
2008	0.8	pump 0.8ccm/rev	2.4	2.4	2.4	2.6	2.7	2.5	mc6s8x75	250	33.6
2012	1.2	pump 1.2ccm/rev	3.2	3.3	3.2	3.6	3.7	3.4	mc6s8x75	251	34.2
2017	1.7	pump 1.7ccm/rev	3.9	4.3	4.1	4.6	4.9	4.6	mc6s8x75	253	35.1
2022	2.2	pump 2.2ccm/rev	4.3	5.2	5.0	5.4	6.0	5.6	mc6s8x80	255	36.1
2026	2.6	pump 2.6ccm/rev	4.4	5.7	5.5	6.0	6.6	6.2	mc6s8x80	256	36.9
2032	3.2	pump 3.2ccm/rev	3.3	6.5	6.3	6.5	7.6	7.3	mc6s8x90	258	38.0
2043	4.3	pump 4.3ccm/rev	3.7	6.6	7.1	5.8	9.1	8.8	mc6s8x90	262	40.0

Other sizes available on request

Pumps with other ports and body shapes available

Pumps with intergrated relief valve available

For alternative pump orientation , please refer to separate drawing

* nominal performance, real values may differ in practical use.

WARNING

This power unit does not contain devices which protects users from the effect of sudden loss of pressure in hydraulic cylinders.

It is responsibility of the user to ensure the conformity of the installation with the local safety and health regulations, including a safety risk assessment.

It is prohibited to utilise the machine in which this product has been integrated before the former has been certified as complying with the conditions of machines guideline.

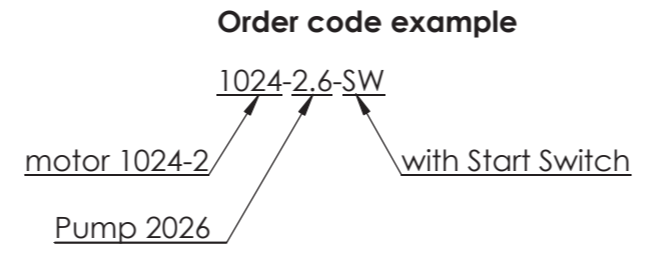

NO.	Name	Part no.	DESCRIPTION	QTY.
1	Motor	See list	with thermal switch	1
2	Pump	See list		1
3	Screw	See list		2
4	Spring washer	8 DIN127B		2
5	Start Switch	See list	SU60 P/ SW80	1

Drawing interpretation unless otherwise specified		First Angle Projection	
Tolerance : ISO 2768-	Drawn: FF	Date	Title
Surface finish :	Approved:	Sheet	2KW Motor-Pump Unit
All measures intends finished product	Scale 1:2	Format A2	Number
		1 of 1	Rev

Rev	Change	Date	Sign	No

Note: HF uses a network of qualified suppliers to ensure availability. There might be minor dimensional and cosmetic differences between drawing and supplied products.