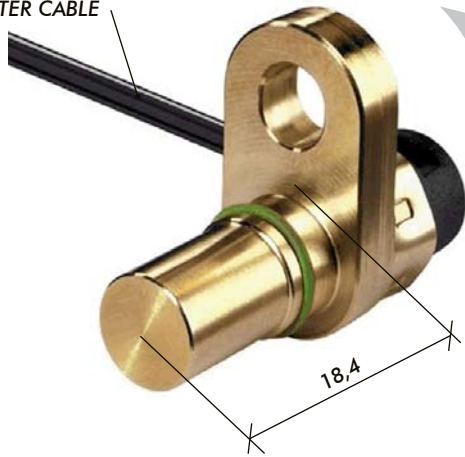

SPEED SENSOR**2 CHANNELS PWM**

1 METER CABLE

**APPLICATIONS**

Speed detection of gearwheels with small module and high resolution.
Applications in vehicles, mobile operating machines and hydraulic drives.

FEATURES

- Choice of different output signal
- Small size
- Alignment required
- Wide temperature range
- Wide frequency range

SAE FLANGE	ISO FLANGE mm	DISPLACEMENT cm ³	OFFSET mm	Z (DENTI)	SENSOR DEPTH mm
SAE B	Ø80	12-17	42	27	18,4
	Ø100	25-34	59		
SAE C	Ø125	40-47 55-64	75	32	
	Ø140	80-91	84	38	
	Ø160	108-130	99		32

TECHNICAL DATA SHEET - MOUNTING

Mounting principle	Directional dependence with asymmetric flange
Tightening torque fixing screw	Max. 8 Nm
Bending radius of connection cable	15 mm
Connection cable material	PUR / EVA
Housing	With flange, perpendicular cable outlet (exits 90° to the axis of the mounting screw)
Housing material	Brass
O-Ring	8,5 x 1 FKM
Air gap (min/max)	Module 1,25: 0,2 mm ... 1,4 mm Module 1,5: 0,2 mm ... 1,8 mm Module 2: 0,2 mm ... 2,4 mm Module 3: 0,2 mm ... 2,9 mm
General mounting instructions	The sensor must be handled with care to prevent damage to the face. To avoid damage to the O-Ring, the sensor must be installed carefully.

TECHNICAL DATA SHEET - ELECTRICAL SPECIFICATIONS

Power supply	4,5 VDC ... 20 VDC
Frequency range	0 Hz ... 12 kHz
Current load	< 200 mA
Short circuit immunity	Yes, output against ground; output against power supply (VDC) to max. 200 mA
Reverse polarity protection power supply lines	Yes, at correctly wired output (max. 195 mA)
Insulation strength	500 VDC
Output	PWM
Output signal level	Low: 4 mA ... 9 mA / High: 12 mA ... 17 mA - Typisch / Typically: 7 mA / 14 mA
Rise-, fall time	< 10 µs

SPEED SENSOR

TECHNICAL DATA SHEET - ELECTRICAL SPECIFICATIONS

Direction of rotation and output signal

Airgap Warning range = LR

Warning information is issued in the output length when the magnetic field is below a critical value. (e. g. the airgap between the Hall Effect IC and the target wheel exceeds a critical value). The device works with reduced functionality. Warning information is given only in calibrated mode.

Assembly position range = EL

EL information is issued in the output pulse length when the magnetic field is below a predefined value (the airgap between the Hall Effect IC and the target wheel exceeds a predefined value). The device works with full functionality.

Direction of rotation right = DR-R

DR-R information is issued in the output pulse length when the target wheel in front of the Hall Effect IC moves from the pin GND to the pin VCC.

Direction of rotation left = DR-L

DR-L information is issued in the output pulse length when the target wheel in front of the Hall Effect IC moves from the pin VCC to the pin GND. At sufficient magnetic field the direction information will be corrected already during uncalibrated mode after 2 pulses.

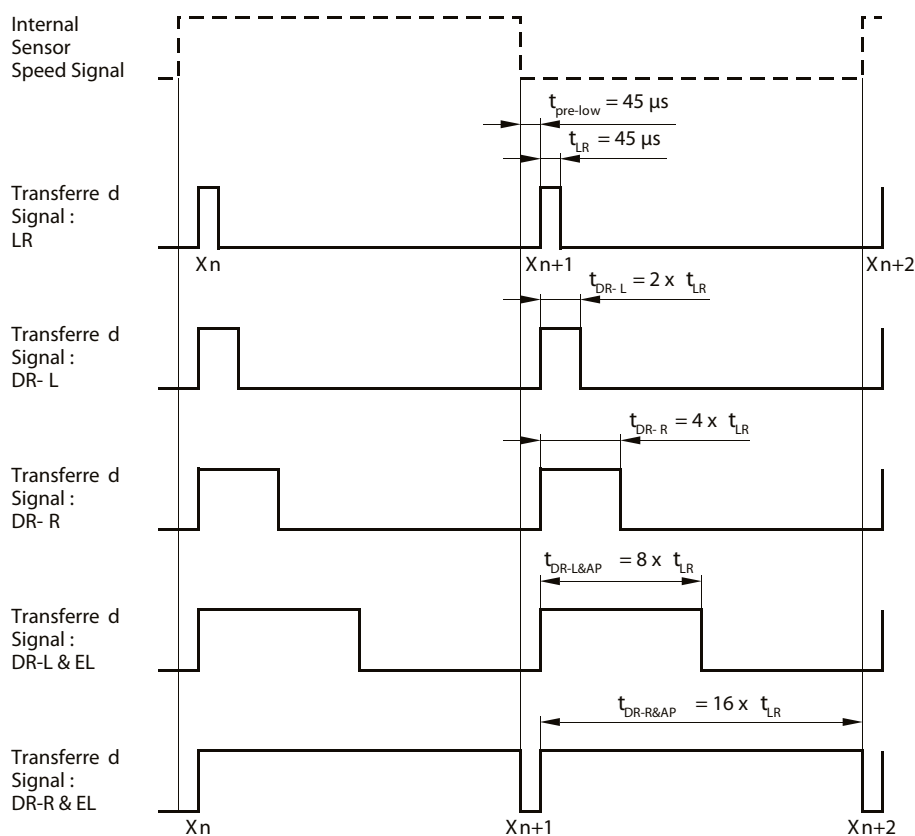

Below 1 Hz every 590 ms ... 848 ms one pulse (1.232 ms ... 1.656 ms) is transmitted

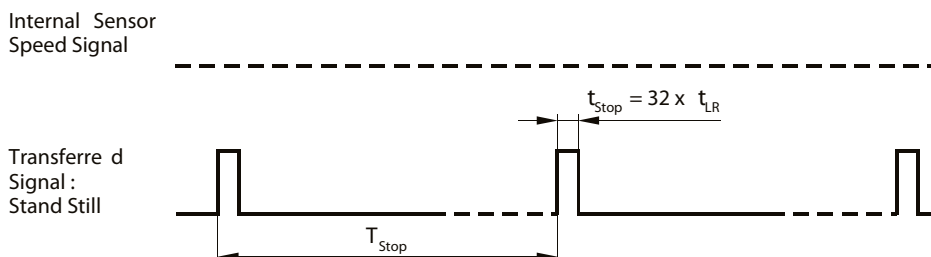

SPEED SENSOR

TECHNICAL DATA SHEET - ELECTRICAL SPECIFICATIONS

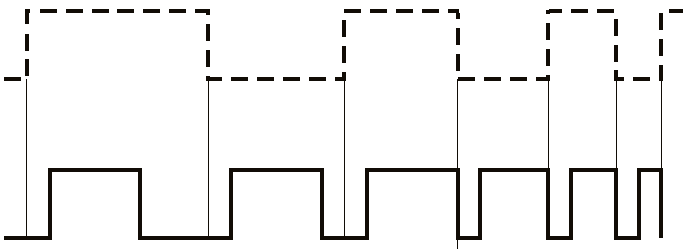
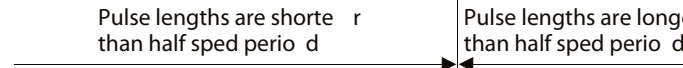
Direction of rotation and output signal	<p>Performance at increasing rotational speed: At increasing revolutions, the next arriving shoulder of the target wheel is detected before the signal could be sent in the scheduled pulse length. In such cases, the signal will be shortened and the low level time (45µs) which appears after each shoulder, will reset the signal. Due to this function, it is guaranteed, that the frequency of the pulses and the revolutions are transmitted correctly. The loss of the direction information in such cases is not critical, because of the high rotational speed, a change of direction is technically not possible. As soon as the speed is reduced (eg decelerate until change of direction), the signal will be transmitted completely and the change of direction is recognized and transmitted.</p> <div style="display: flex; align-items: center;"> <div style="margin-right: 20px;"> <p>Internal Sensor Speed Signal at Increasing Speed</p>  </div> <div style="margin-right: 20px;"> <p>Transferred Signal</p>  </div> </div> <p style="text-align: center;">Pulse lengths are shorter than half speed period Pulse lengths are longer than half speed period</p>
---	---

TECHNICAL DATA SHEET - CONNECTIONS

Cable	2-core, 0.35 mm ² , unshielded	
Cable terminal assignment	Red:	VDC
	Black:	Signal

TECHNICAL DATA SHEET - ENVIRONMENTAL CONDITIONS

Operating temperature range, sensor	-40 °C ... +140 °C (-40 °F ... +284 °F)
Environmental resistance of housing (ISO 16750-5)	Brine and various hydraulic oils, diesel oils, cleaning fluids, Salt spray (EN 60068-2-11): 48h
Max. pressure on sensing surface	Static: 25 bar (362 psi)
Degree of protection (EN 60529)	Sensor side: IP6K9K / IP67
Vibration resistance (EN 60068-2-6)	0,05 g ² /Hz 20 Hz ... 2000 Hz
Shock resistance (EN 60068-2-27)	100 g @ 6 ms, 3x per direction
Temperature shock	20 cycles: 25 min @ +140 °C (+284 °F) air - 10 min @ +20 °C (+68 °F) water
Temperature cycles (EN 60068-2-14)	100 cycles -40 °C to +125 °C @ 5 K/min
EMC standards	ISO 11452-5:2005-8 / ISO TR 10605:2008 / ISO 7637-1:2002
Useful life period (MTTF, electronic) (SN29500)	125 years (1,090,000 h) at +212 °F 250 years (2,100,000 h) at +212 °F
Declaration of conformity (EN 60947-5-2)	EN 61000-4-2:1995 + A1:1998 + A2:2001: 8 kV air, 4 kV contact EN 61000-4-3:2006 + A1:2007 / EN 61000-4-4:2004 + A1:2004 / EN 61000-4-6:2007 + Corrigendum 2007 / EN 61000-4-8:1993 + A1:2001

Codice fascicolo:997-400-24410

Data: Venerdì 28 settembre 2018

Codice foglio:997-318-00186 Rev: AB



SAFETY INSTRUCTIONS



General instructions

- Opening, modifying or repairing the speed sensor are not permissible. Modifications or repairs to the cable could lead to dangerous malfunctions.
- System developments, installations and commissioning of electronic systems for controlling hydraulic drives must only be carried out by trained and experienced specialists who are sufficiently familiar with both the components used and the complete system.
- When commissioning the speed sensor, the machine may pose unforeseen hazards. For this reason, before commissioning the system, you must ensure that the vehicle and the hydraulic system are in a safe condition.
- Make sure that nobody is in the machine's danger zone.
- No defective or incorrectly functioning components may be used. If the speed sensor should fail or fail to operate properly, it must be replaced.
- Despite every care being taken when compiling this document, it is not possible to take into account all feasible applications.
If instructions for your specific application are missing, you can contact OMFB S.p.A. Hydraulic Components.

Notes on the installation point and position

- Do not install the speed sensor close to parts that generate considerable heat (e.g., exhaust).
- Wires are to be routed with sufficient spacing to hot or moving vehicle parts.
- A sufficiently large distance to radio systems must be maintained.
- The connector of the speed sensor is to be unplugged prior to electrical welding and painting operations.
- Cables/wires must be sealed individually to prevent water from entering the device.

Notes on transport and storage

- Please examine the devices for any signs of transport damage. If obvious damage is present, please notify the transport contractor and OMFB S.p.A. Hydraulic Components without delay.
- If the speed sensor is dropped, continued use is not permissible because unseen damage may affect its reliability.

Notes regarding the connection and the wiring

- Lines to the speed sensors are to be shielded and kept as short as possible and be shielded. The shield must be connected to the electronics on one side or to the machine or vehicle ground via a low-resistance connection.
- The speed sensor should only be plugged and unplugged when it is in a de-energized state.
- The sensor cables are sensitive to radiation interference. For this reason, the following measures should be taken when operating the sensor:
 - Sensor cables should be attached as far away as possible from large electric machines.
 - If the signal requirements are satisfied, it is possible to extend the sensor cable.
- Lines from the speed sensor to the electronics must not be routed close to other power-conducting lines in the machine or vehicle.
- The cable harness should be mechanically secured in the area in which the sensor is installed (spacing < 150 mm). The cable harness should be secured so that in-phase excitation with the sensor occurs (e.g. at the sensor bolting point).
- If possible, wires should be routed in the vehicle interior. If the wires are routed outside the vehicle, make sure that they are securely fixed.
- Wires must not be kinked or twisted, must not rub against edges and must not be routed through sharp-edged ducts without protection.

Intended use

- Operation of the speed sensor must generally occur within the operating ranges specified and released in this data sheet, particularly with regard to voltage, temperature, vibration, shock and other described environmental influences.
- Use outside of the specified and released boundary conditions may result in danger to life and/or cause damage to components which could result in consequential damage to the mobile working machine.

Improper use

- Any use of the speed sensor other than that described in the chapter headed "Intended use" will be considered to be improper use.
- Use in explosive areas is not permissible.
- Damages which result from improper use and/or from unauthorized, unintended interventions in the device not described in this data sheet render all warranty and liability claims with respect to the manufacturer void.

Use in safety-related functions

- The customer is responsible for performing risk analysis on the entire system and for defining possible safety-related functions.
- In safety-related applications, the customer is responsible for taking suitable measures to ensure safety (sensor redundancy, plausibility check, emergency switch, etc.).
- Product data that is necessary to assess the safety of the machine can be provided on request or are listed in this data sheet.

Disposal

- The speed sensor must be disposed of in accordance with the national regulations of your country.