



DIRECT CURRENT SOLENOIDS FOR HYDRAULICS MR

- Fast and simple installation.
- Reliable functioning in every position.
- Long life span.
- Solenoid screws into valve block.
- Removable coil.
- Corresponding to VDE 0580 recommendations.
- Plug-in connector corresponding to EN 175301-803 standards.
- MR - 045 fulfil EMC (89/336/EEC).
- Protection of solenoid: IP 69 for Deutsch connector
IP 65 to EN 50529 / IEC 60529 for AMP connector



MR - 060, MR - 045, MR - 045/1

Operation

A piston that can move freely lengthwise, is placed in an oiltight core (1). A coil (2) protected by housing surrounds the core. The plug-in connector (4) is fixed to the housing. The coil is fixed on the core by retaining nut (3) and protected against rotation with a pin (5).

This type of solenoid is used for controlling of directional control valves.

They are activated by passing electric current through the solenoid's coil. For manually operation of the solenoid, there is the emergency switch at the back of the solenoid. Solenoids are of «push-design». When the solenoid is activated the piston pushes the piston rod out of it. The force with which the piston pushes at various points of its stroke (solenoid's movement) is given in the tables. The solenoids are designed for direct current. If a rectifier bridge is added, the alternating current can also be used. They are built for voltages of 12, 24, 48, 110 and 230V. Allowed deviation from the nominal voltage is within -10 to +5%. Their intermittence is 100% at the ambient temperature of 40°C [104°F]. When the ambient temperature is increased the intermittence is correspondingly lowered.

If the buyer so wishes, solenoids have the degree of protection of enclosures IP 65. They are tested to the pressure of 250 bar [3 626 PSI]. Their life span in normal working conditions is 10⁷ operations.

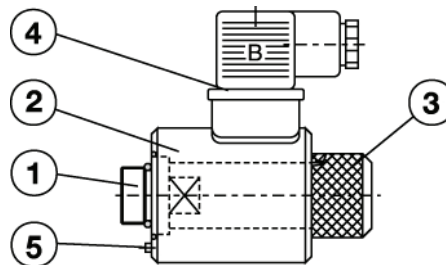

Features

		MR-045 for NG6 5KO	MR-045/1 for NG6 3KO	MR-060 for NG10
	Strokkem [Zoll]			
	0 [0]	100 [22.5]	90 [20.2]	240 [53.9]
	1 [0.04]	75 [16.9] / 70* [15.7]*	50 [11.2]	130 [29.2]
	2 [0.08]	60 [13.5] / 50* [11.2]*	35 [7.9]	
	3 [0.12]	30 [6.7] / 20* [4.5]*	20 [4.5]	140 [31.5]
	4 [0.16]	20 [4.5] / 10* [2.2]*	10 [2.2]	85 [19.1]
	5 [0.20]	8 [1.8] / 5* [1.1]*	5 [1.1]	50 [11.2]
	6 [0.24]	5 [1.1] / 3* [0.7]*	3 [0.7]	35 [7.9]
	7 [0.28]	-	-	23 [5.2]
	8 [0.31]	-	-	18 [4.0]
	9 [0.35]	-	-	13 [2.9]
Force F at 90% Un, and working temperature when ED is 100%	N [lbf]			
(* 230 V AC supply voltage)				
Power (** 12V supply voltage - 36W)	W	29**	26	45
Pression	Bar [PSI]	250 [3 626]		
Intermittence	%	100		
Mass	kg [lbs]	0,6 [1.32]	0,45 [0.99]	1,6 [3.52]



Dimensions

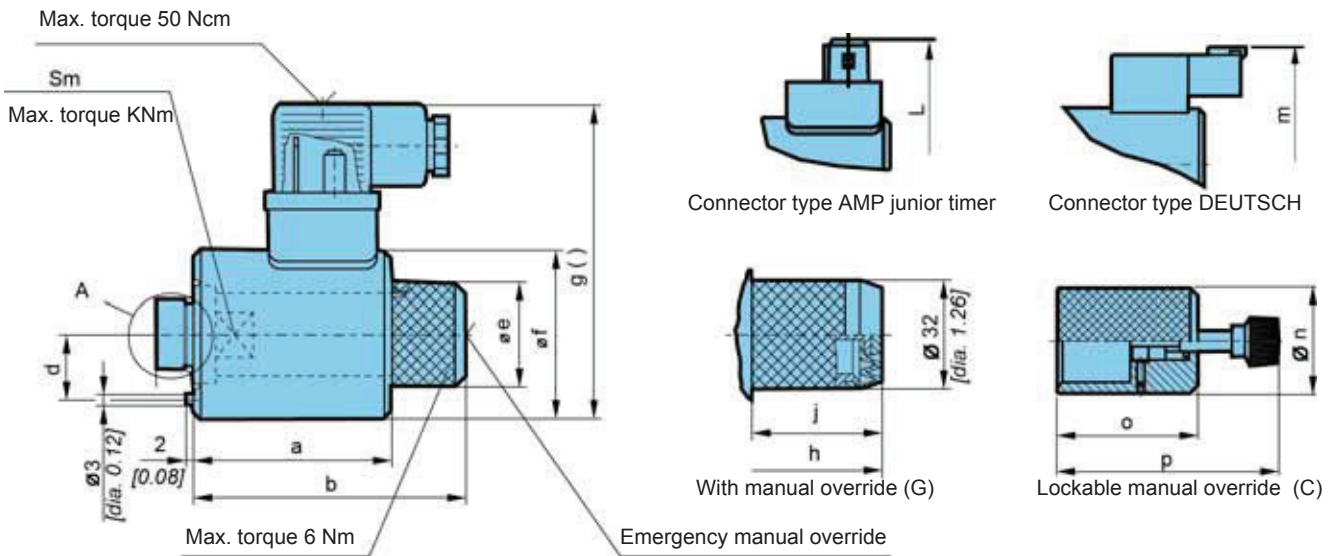

	a	b	D ^{+0.1}	Øe	Øf	g	h	j
MR-045	53 [2.08]	73 [2.87]	17,5 [0.69]	30 [1.18]	45 [1.77]	85 [3.35] / 91* [3.58]*	87 [3.42]	34 [1.34]
MR-045/1	38 [1.49]	58 [2.28]					72 [2.83]	
MR-060	72 [2.83]	108 [4.25]	23,9 [0.94]	40 [1.57]	62 [2.44]	103 [4.05] / 109* [4.29]*	122 [4.80]	50 [1.97]

* AC supply voltage

	k	L	Sm	m	n	o	p
MR-045	30 [1.18]	69 [2.72]	20 [0.78]	67 [2.64]	28 [1.10]	35 [1.38]	61 [2.40]
MR-045/1							
MR-060	50 [1.97]	86 [3.38]	27 [1.06]	82 [3.23]	40 [1.57]	54 [2.13]	79,5 [3.13]



A MR-045

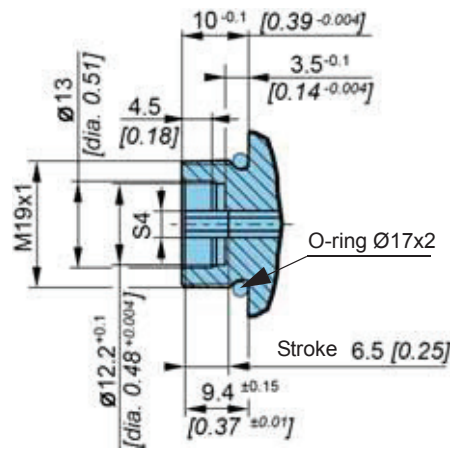

Pressure switches

A MR-045/1

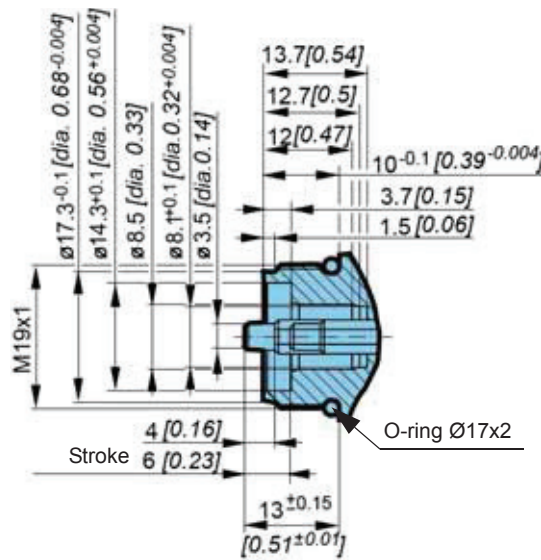

Solenoids

A MR-060

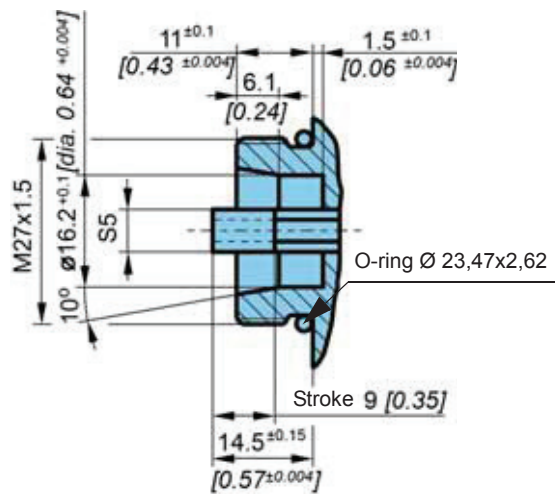

Joystick

Amplifier



Model code (Every part of solenoid has to be ordered separately)

Core



Size [Zoll]

Ø 45 [1.77 dia] / Length 73 [2.87]	045
Ø 45 [1.77 dia] / Length 58 [2.28]	045/1
Ø 60 [2.36 dia] / Length 108 [4.25]	060

For DC and AC voltage the same core is used.

Retaining nut



Size [Zoll]

Ø 45 [1.77 dia] / Length 73 [2.87]	045
Ø 45 [1.77 dia] / Length 58 [2.28]	045/1
Ø 60 [2.36 dia] / Length 108 [4.25]	060

Hand operation of solenoid

Without	No designation
Manual override	G
Lockable manual override	C

Coil



Size [Zoll]

Ø 45 [1.77 dia] / Length 73 [2.87]	045
Ø 45 [1.77 dia] / Length 58 [2.28]	045/1
Ø 60 [2.36 dia] / Length 108 [4.25]	060

Supply voltage

	Direct voltage	Alternating voltage
12V	12 DC	12 AC
24V	No designation	24AC
48V	48DC	48AC
110 V	110DC	110AC
230V	230DC	230AC*

* To fulfil EMC (89/336/EEC) a capacitor must be built in.

Connector type

EN 175301-803	No designation
AMP Junior Timer	AMP
DEUTSCH	DEU

Overvoltage

Without overvoltage protection	No designation
With overvoltage protection	T

Plug-in connector



Supply voltage

	Direct voltage	Alternating voltage
12V	12 DC	12 AC
24V	No designation	24AC
48V	48DC	48AC
110 V	110DC	110AC
230V	230DC	230AC*

* To fulfil EMC (89/336/EEC) a capacitor must be built in.

Solenoid with rectifier bridge built in connector

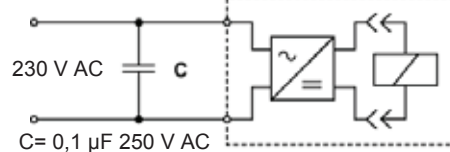

Solenoid with overvoltage protection

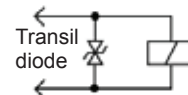

Colour signal lamp

Grey without signal lamp	A**
Black without signal lamp	B
Transparent with signal lamp	L**

Cable gland**

S. 9	No designation
S. 11	11

** not valid for AMP and DEUTSCH