

STANDARD

Food couplings complying with DIN 11851 are used in the food, chemical and pharmaceutical industries to connect rubber food hoses and stainless steel pipes (in compliance with DIN 11850).

On request food couplings complying with DIN 11864 available.

OPERATION

The seal must be inserted correctly into the seal sitting of the male coupling before connection. The conical female coupling is then pushed onto the male threaded coupling. The two are secured by sliding the nut across the conical head of the female coupling and onto the thread of the male coupling. The flanged seal enables easy assembly and prevents any displacement by vacuum or pressure.

Threaded food couplings complying with DIN 11851 have a rounded thread complying with DIN 405/1. This rounded thread ensures that DIN 11851 compliant food couplings are easy to connect by hand or using a wrench.

FEATURES

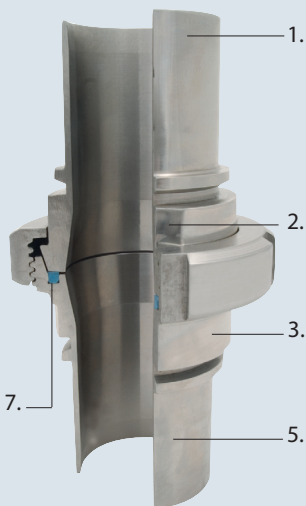

1. Electro-polished external surface for improved hygiene
2. Wrench surface to prevent twisting of the hose when fitting one half of the coupling to the other half.
3. Extra-long head for easy assembly and disassembly
4. Low Ra-value up to $\leq 1.6 \mu\text{m}$
5. Hose shank for assembly with RK safety clamps, or FLEXOLINE[®] safety clamps or HHRK or HRP swage ferrules
6. Easy assembly of protection ring
7. Standard NBR seal, form G conforming FDA directive and ADI-free



CONNECTION

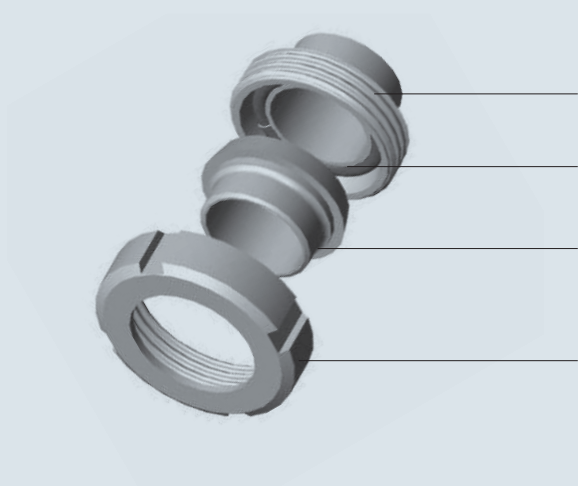

1. Male threaded welding coupling type DIN213...
2. NBR seal type DIN211...
3. Female welding coupling type DIN214...
4. Nut type DIN210...

Food couplings complying with DIN 11851 vs SMS

	DIN 11851	SMS
Female coupling	Conical face	Flat face
Male coupling	Deep seal	Turned-up seal
Seal	U-shape seal	Square seal
Male and female thread	Rounded thread complying with DIN 405/1	Rounded thread complying with DIN 405/1
Max. working pressure	40 bar / 580 psi	6 bar / 87 psi

DIN 11851

SMS



APPLICATION

For the food, beverage, pharmaceutical and chemical industries.

WORKING PRESSURE

ND	ID	BAR	PSI
15	13	40	580
20	19	40	580
25	25	40	580
32	32	40	580
38	38	40	580
40	40	40	580
50	50	25	360
63	63	25	360
65	65	25	360
75	75	25	360
80	80	25	360
100	100	25	360

TEMPERATURE

-30°C / -22°F up to 120°C / 250°F, depending on the seal material used.

MATERIAL

- Coupling
 - Stainless steel AISI 316 - EN 1.4401 = shank (standard)
 - Stainless steel AISI 304 - EN 1.4301 = nut and cap (standard)

- Seal
 - NBR (standard);
 - EPDM;
 - FPM;
 - H-NBR, available on request

ASSEMBLY

1. RK safety clamps complying with EN 14420-3 / DIN 2817
2. FLEXOLINE[®] safety clamps
3. HRRK or HRP swage ferrules
4. Welding

THREADS

Food couplings complying with DIN 11851 are not interchangeable with SMS food couplings. Although the threads of both couplings comply with DIN 405/1, precise dimensions vary, making them non-interchangeable.

ND	THREAD COMPLYING WITH DIN 405/1
15	RD 34 x 1/8"
20	RD 44 x 1/6"
25	RD 52 x 1/6"
32	RD 58 x 1/6"
38	RD 65 x 1/6"
40	RD 65 x 1/6"
50	RD 78 x 1/6"
63	RD 95 x 1/6"
65	RD 95 x 1/6"
75	RD 104 x 1/6"
80	RD 110 x 1/4"
100	RD 130 x 1/4"

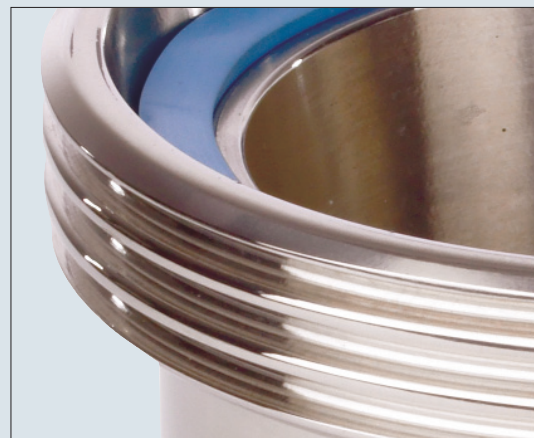

RA-VALUE

Roughness average value (Ra-value) DIN 11851 couplings

1. Ra-value inner side $\leq 1.6 \mu\text{m}$
2. Ra-value outer side $\leq 3.2 \mu\text{m}$

Other Ra-values and Ra-report available on request.