

# HYDRAULIC DISC BRAKES LB, LBS, LBV- Wet



## APPLICATION

- » Heavy Duty machinery
- » Wheel drives
- » Material handling
- » Mining
- » Agricultural machines
- » Conveyors
- » Door openers and swing drives etc.



## GENERAL

<b>Fluid type</b>	Mineral based- HLP(DIN 51524) or HM(ISO 6743/4)
<b>Temperature range, °C [°F]</b>	-40÷140 [-40÷284]
<b>Viscosity range, mm<sup>2</sup>/s</b>	20÷75 [98÷347]
<b>Filtration</b>	ISO code 20/16 (nominal filtration of 25 microns)
<b>Maintenance</b>	Changed after the first 50-100 h, then after every 500-1500 h.

## CONTENTS

Hydraulic Disc Brake for MP, MR and MS Motors type LB/288 .....	4÷5
Hydraulic Disc Brake for MSS and MSV type LBS(V)/289 .....	6
Hydraulic Disc Brake for MSS and MSV type LBS(V)/290 .....	7
Output Shafts for LBS(LBV)/289, 290 .....	8
Specification data for LBS(LBV)/289, 290 .....	8
Load curve for LBS(LBV)/289, 290 .....	8
Internal Spline data for .../289,290 and .../314,315.....	9
Order code for LB/288,LBS(LBV)/289, 290 .....	9
Hydraulic Disc Brake for MTS and MTV type LBS(LBV)/314 .....	10
Hydraulic Disc Brake for MTS and MTV type LBS(LBV)/315 .....	11
Specification data for LBS(LBV)/314, 315 .....	12
Load curve for LBS(LBV)/314, 315 .....	12
Output Shafts for LBS(LBV)/314, 315 .....	13
Order code for LBS(LBV)/314, 315 .....	13
Hydraulic Disc Brake for MVS type LBS/313 .....	14
Load curve for LBS/313 .....	14
Hydraulic Disc Brake for MVS type LBS/316 .....	15
Load curve for LBS/316 .....	15
Specification data for LBS/313, 316.....	16
Output Shafts for LBS/313, 316 .....	16
Internal Spline data for LBS/313, 316 .....	17
Order code for LBS/313, 316 .....	17

### LB, LBS

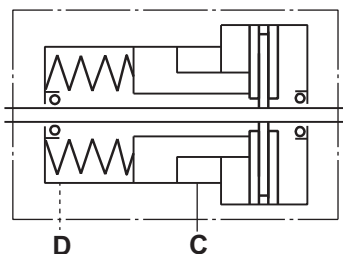

### LBV

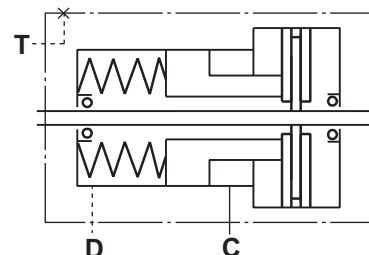

**HYDRAULIC DISC BRAKE FOR FLANGE ATTACHMENT TO MP, MR AND MS HYDRAULIC MOTORS**

**TYPE LB/288**

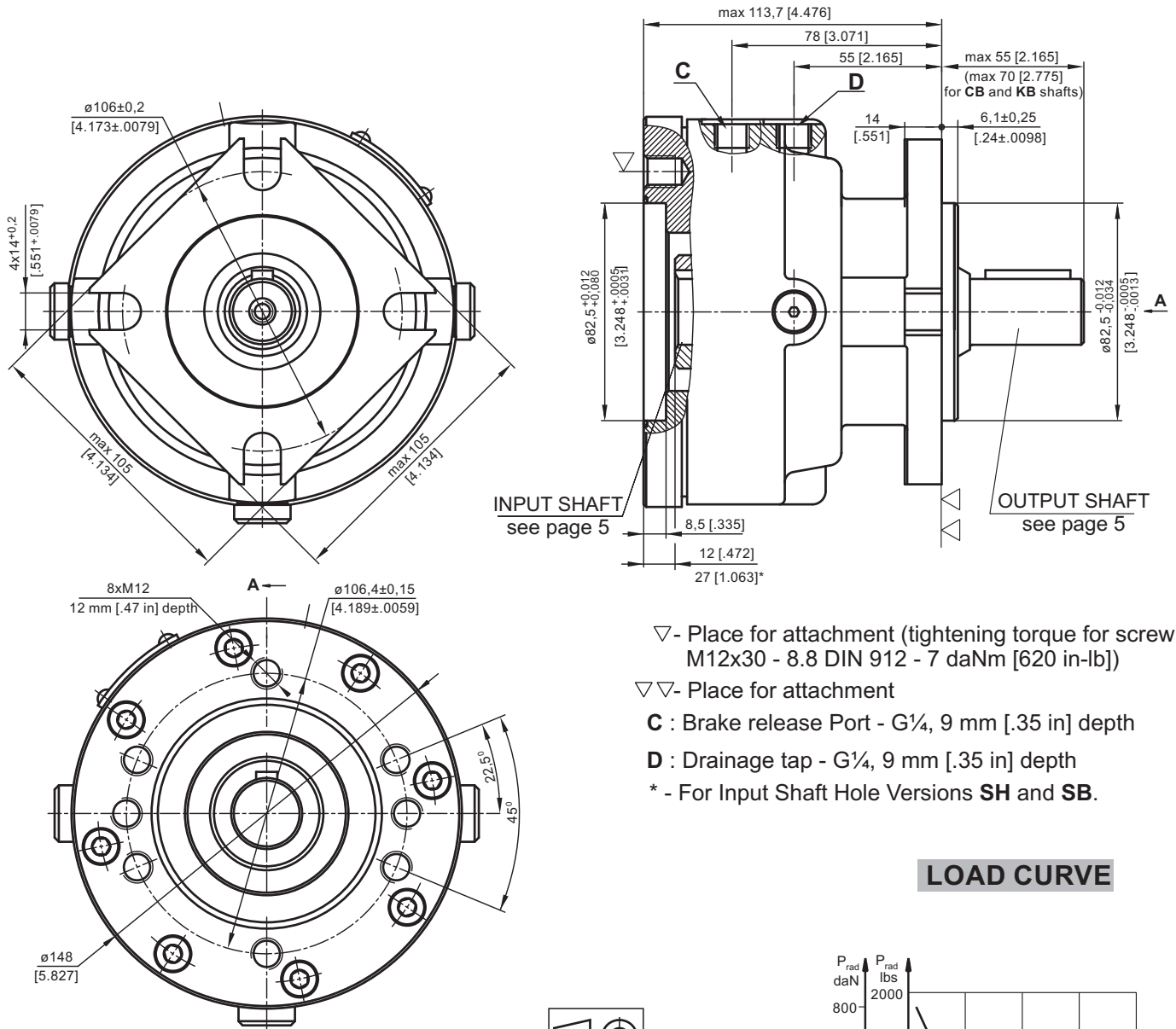

- ▽ - Place for attachment (tightening torque for screw M12x30 - 8.8 DIN 912 - 7 daNm [620 in-lb])
- ▽▽ - Place for attachment
- C** : Brake release Port - G¼, 9 mm [.35 in] depth
- D** : Drainage tap - G¼, 9 mm [.35 in] depth
- \* - For Input Shaft Hole Versions **SH** and **SB**.

**LOAD CURVE**

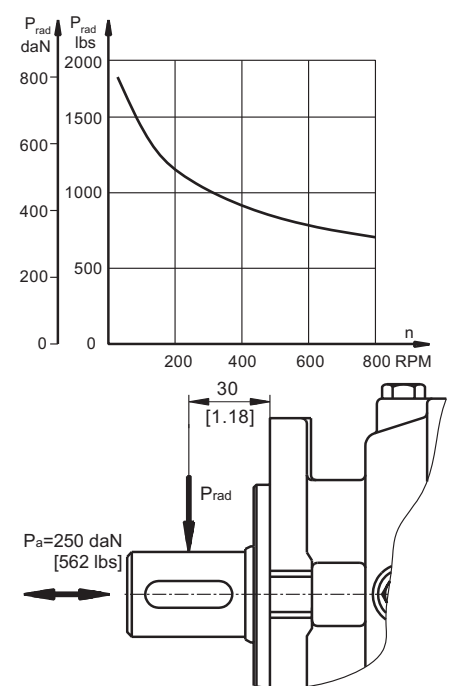

**SPECIFICATION DATA**

Description <b>LB/288...</b>	7	14	21	32	43	63
*Min. Static Torque, daNm [lb-in]	6-8 [531-708]	13-15 [1150-1327]	20-22 [1770-1947]	31-34 [2743-3009]	41-45 [3628-3982]	61-64 [5399-5665]
Opening Pressure, min bar [PSI]	4-8 [58-116]	9-16 [130-232]	12-13 [174-188]	18-20 [260-290]	24-26 [348-377]	38-39 [550-565]
max	300 [4350]					
Min. oil quantity for brake releasing, cm <sup>3</sup> [in <sup>3</sup> ]	7 - 8 [4.27 - .488]					
Oil volume cm <sup>3</sup> [in <sup>3</sup> ]	50 - 120 [3.5 - 7.35]					
Max. Pressure in drain space, bar [PSI]	0,5 [7.25]					
Weight, kg [lb]	9 [19.8]					

\*Static torque is obtained at working pressure - 0 bar [0 PSI].

**INPUT SHAFT HOLES**

**OUTPUT SHAFT EXTENSIONS**

**C**

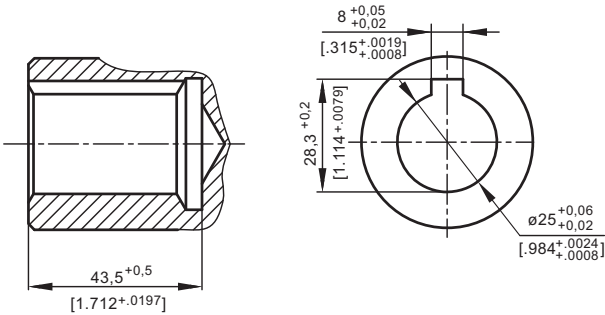

**CO**

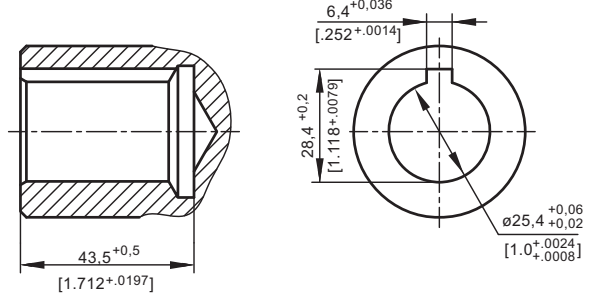

**SH**

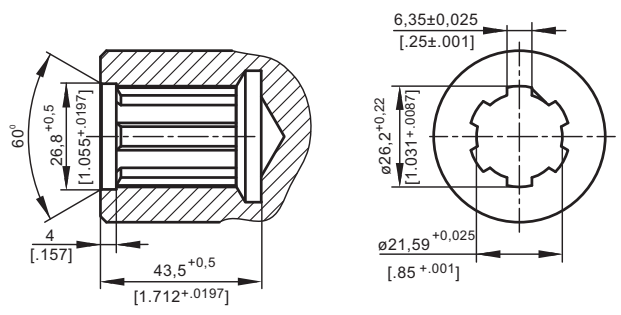

**SB**

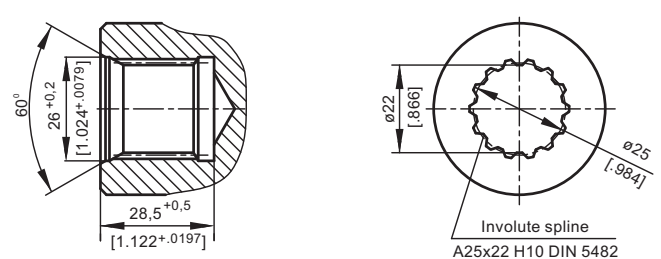

**CB**

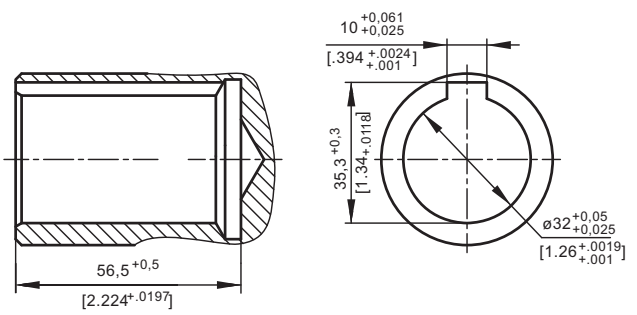

**C**

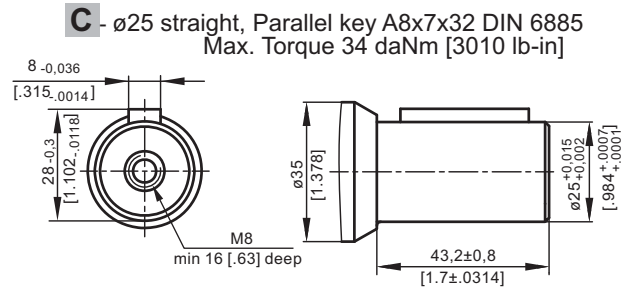

**CO**

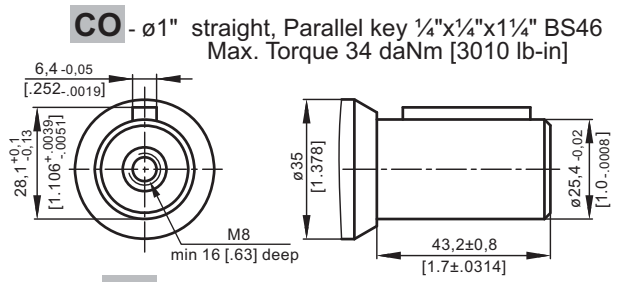

**SH**

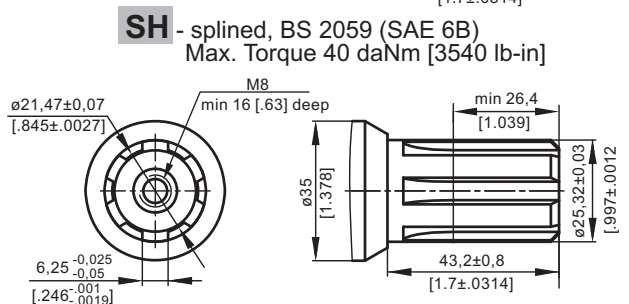

**SA**

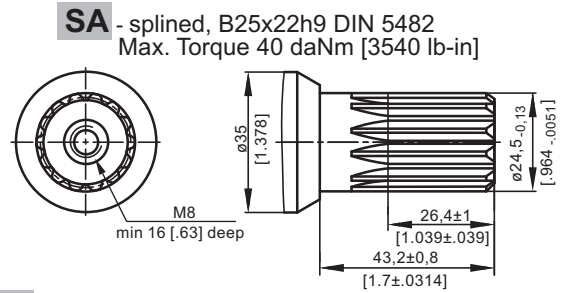

**CB**

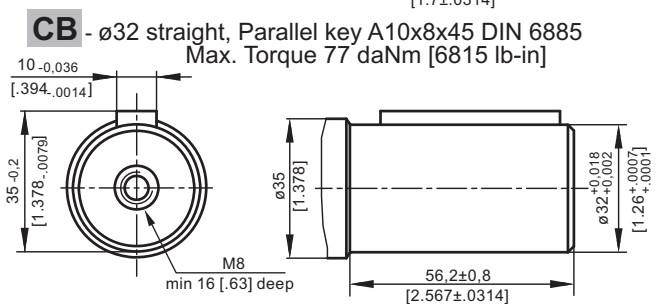

**KB**

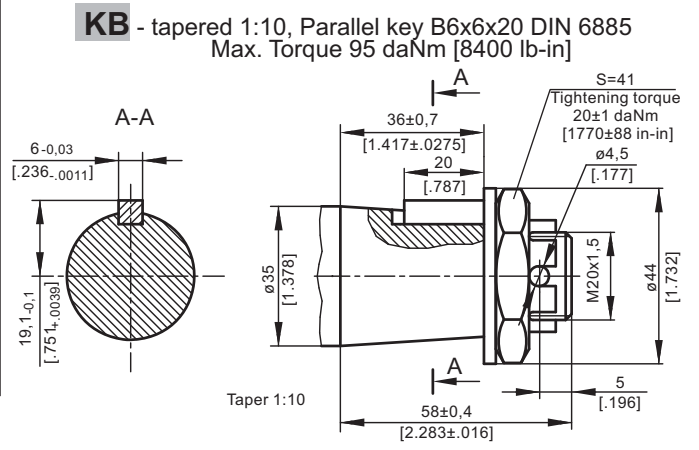

**HYDRAULIC DISC BRAKE FOR FLANGE ATTACHMENT  
TO MSS AND MSV HYDRAULIC MOTORS**

**TYPE LBS/289**

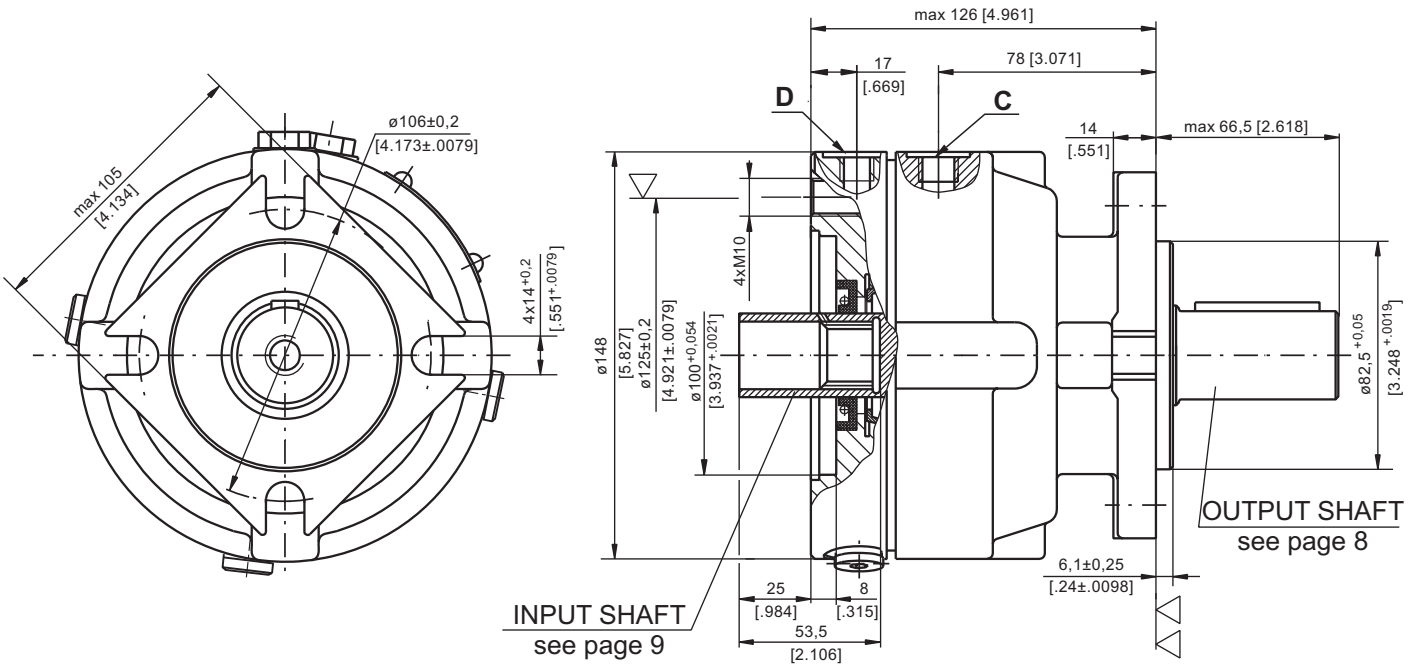

- ▽ - Place for attachment  
(tightening torque for screw M10x35 - 8.8 DIN 912 - 5 daNm [440 lb-in])
- ▽▽ - Place for attachment



**TYPE LBV/289**

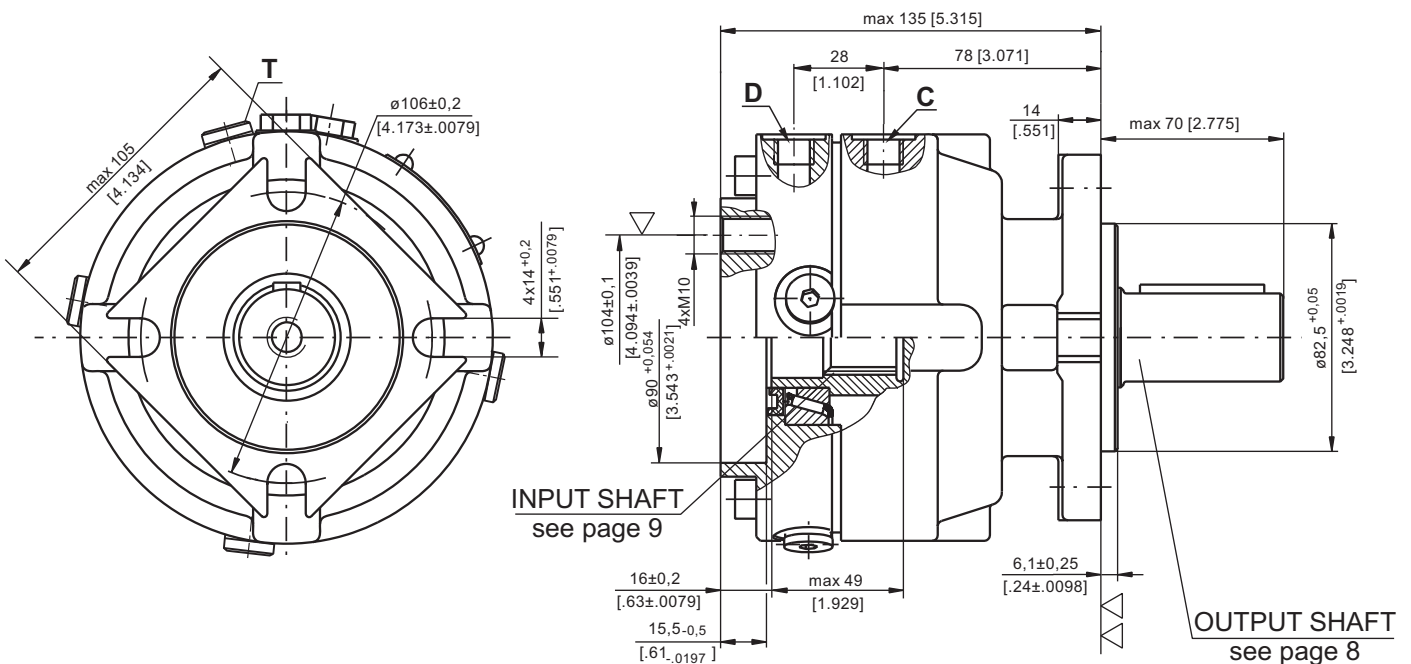

- ▽ - Place for attachment  
(tightening torque for screw M10 - 8.8 DIN 912 - 5 daNm [440 lb-in])
- ▽▽ - Place for attachment

**C** : Brake release Port - G $\frac{1}{4}$ , 9 mm [.35 in] depth

**D, T**: Drainage tap - G $\frac{1}{4}$ , 9 mm [.35 in] depth

**HYDRAULIC DISC BRAKE FOR FLANGE ATTACHMENT TO MSS AND MSV HYDRAULIC MOTORS**

**TYPE LBS/290**

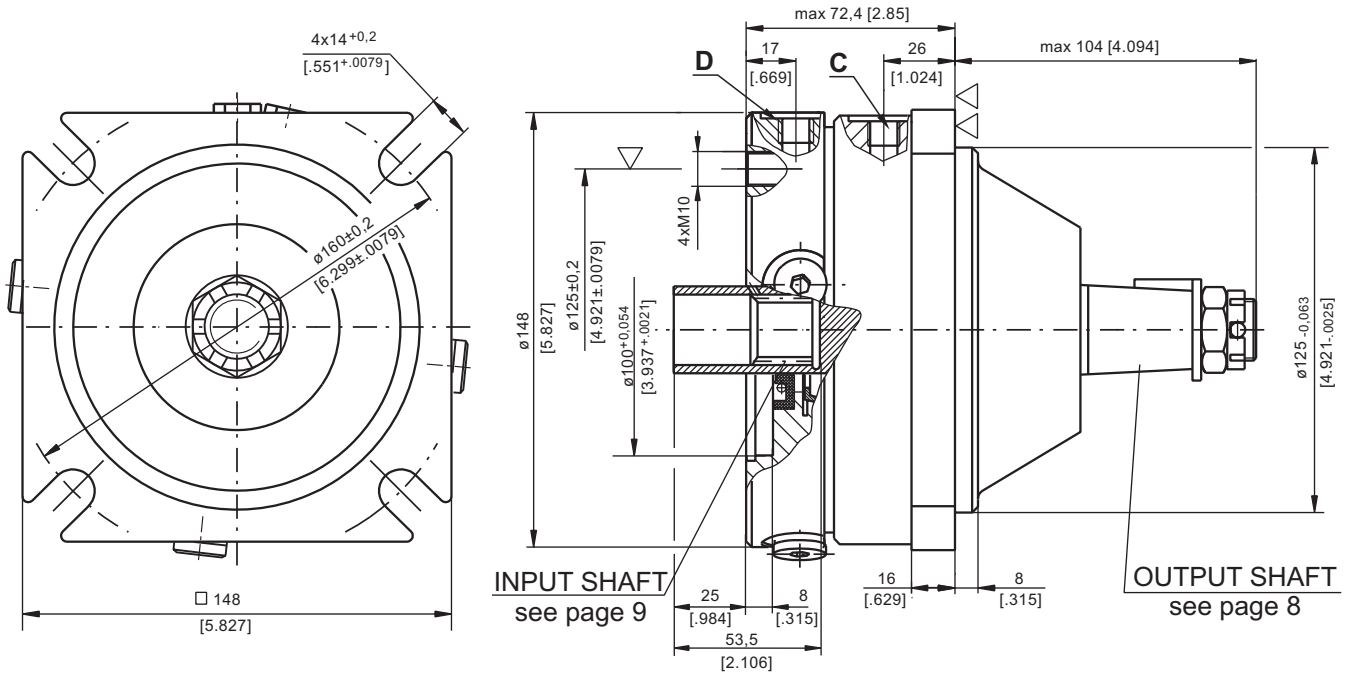

▽ - Place for attachment  
(tightening torque for screw M10x35 - 8.8 DIN 912 - 5 daNm [440 lb-in])

▽▽ - Place for attachment



**TYPE LBV/290**

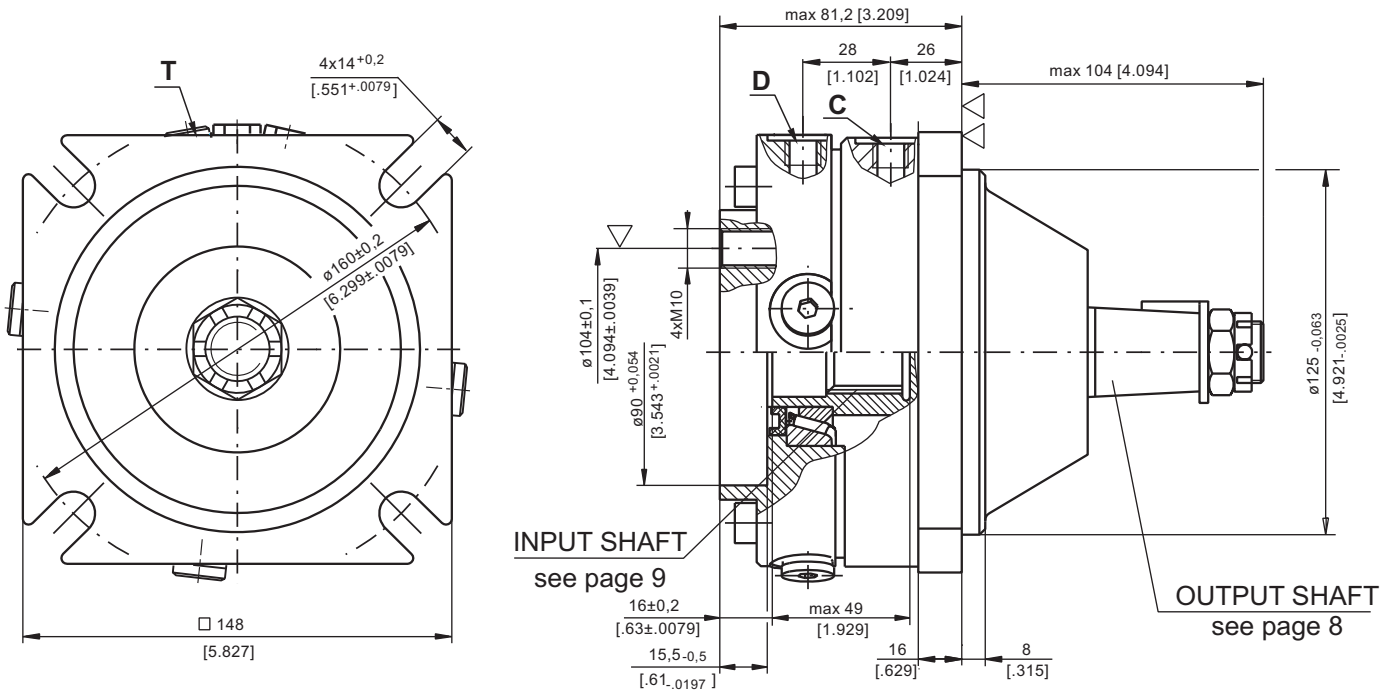

▽ - Place for attachment  
(tightening torque for screw M10 - 8.8 DIN 912 - 5 daNm [440 lb-in])

**C** : Brake release Port - G $\frac{1}{4}$ , 9 mm [.35 in] depth

**D, T**: Drainage tap - G $\frac{1}{4}$ , 9 mm [.35 in] depth

▽▽ - Place for attachment

**OUTPUT SHAFT EXTENSIONS**

**CB** -  $\phi 32$  straight, Parallel key A10x8x45 DIN 6885  
Max. Torque 77 daNm [6815 lb-in]

**KB** - tapered 1:10, Parallel key B6x6x20 DIN 6885  
Max. Torque 95 daNm [8400 lb-in]

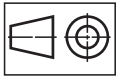
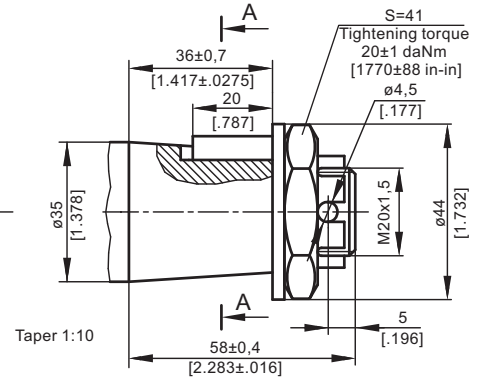
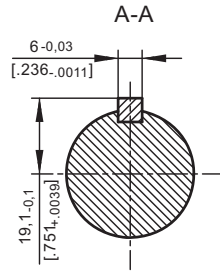
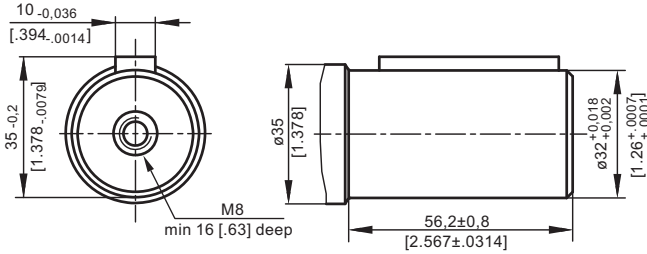

mm [in]

**SPECIFICATION DATA**

Description LBS/289(290) LBV/289(290)	21	32	43	63
*Min. Static Torque, daNm [lb-in]	20-22 [1770-1947]	31-34 [2743-3009]	41-45 [3628-3982]	61-64 [5399-5665]
Opening Pressure bar [PSI]	min 12-13 [174-188]	18-20 [260-290]	24-26 [348-377]	38-39 [550-565]
	max	300 [4350]		
Min. oil quantity for brake releasing cm <sup>3</sup> [in <sup>3</sup> ]	7 - 8 [.427 - .488]			
Oil volume cm <sup>3</sup> [in <sup>3</sup> ]	50 - 120 [3.05 - 7.35]			
Max. Pressure in drain space bar [PSI]	5 [72]			
Weight kg [lb]	9 [19.8]			

\*Static torque is obtained at working pressure - 0 bar [0 PSI].

**LOAD CURVE**

The curve applies to a B10 bearing life of 3000 hours at 200 RPM.

- 1: Pa < 350 daN [787 lbs]
- 2: Pa = 500 daN [1125 lbs]

**LBS(V)/289**

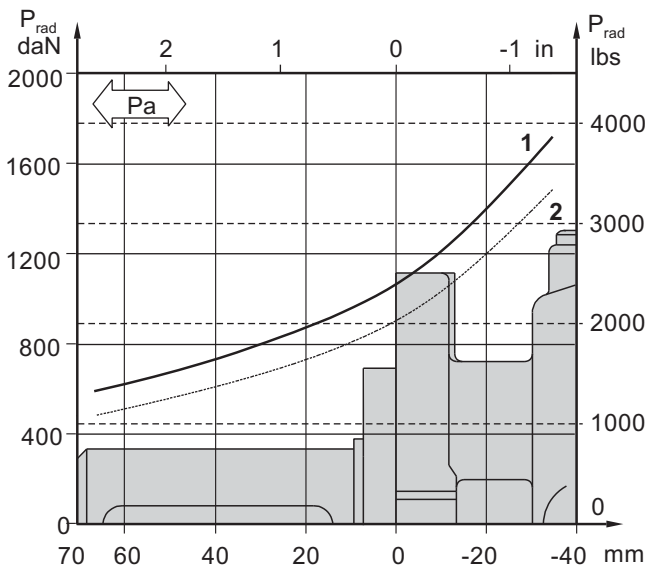

**LBS(V)/290**

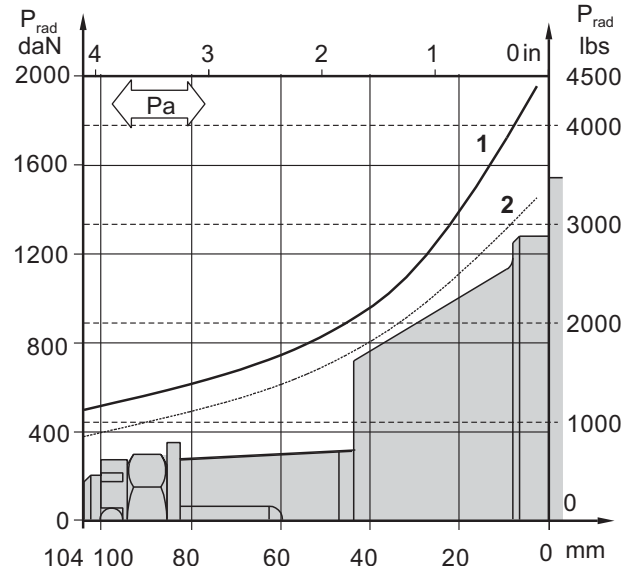



**INTERNAL SPLINE DATA FOR THE ATTACHED COMPONENT**

Standard ANS B92.1-1970, class 5

[m=2.1166]

Fillet Root Side Fit	LBS(V)/289 LBS(V)/290		LBS(V)/314 LBS(V)/315		
	mm	inch	mm	inch	
Number of Teeth	z	12	12	16	16
Diametral Pitch	DP	12/24	12/24	12/24	12/24
Pressure Angle		30°	30°	30°	30°
Pitch Dia.	D	25,4	1	33,8656	1.3333
Major Dia.	D <sub>ri</sub>	28,0 <sup>-0,1</sup>	1.1 ± 1.098	38,4 <sup>+0,4</sup>	1.5118±1.5275
Minor Dia.	D <sub>i</sub>	23,0 <sup>+0,033</sup>	.907 ± .905	32,15 <sup>+0,06</sup>	1.2657±1.2673
Space Width [Circular]	Lo	4,308±0,020	.1704 ± .1688	4,516±0,037	.1763±.1791
Fillet Radius	R	0,2	.008	0,5	.02
Max. Measurement between Pins	L	17,62 <sup>+0,15</sup>	.699 ± .694	26,9 <sup>+0,10</sup>	1.063±1.059
Pin Dia.	d	4,835±0,001	.19039±.19031	4,835±0,001	.19026±.19034
Corrected	x.m	+0,8	+0,031	+1,0	+0,039

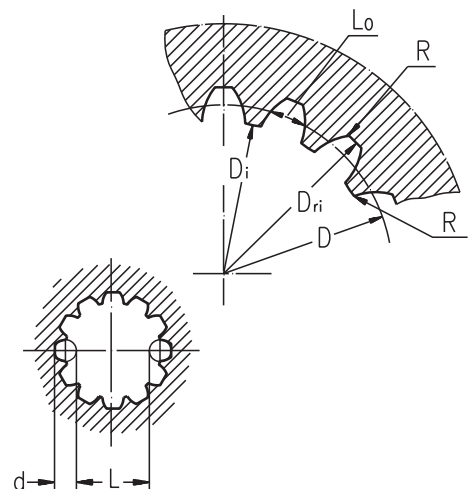

**ORDER CODE - LB/288**

	1	2	3	4	5
<b>LB/288</b>		-			

**Pos.1 - Input Shaft Hole**

**C, CO, SH, CB, SB**

**CB** - ø32 straight, Parallel key A10x8x45 DIN 6885

**KB** - ø35 tapered 1:10, Parallel key B6x6x20 DIN6885

**Pos.2 - Static Torque code (See Specification data)**

**7, 14, 21, 32, 43, 63**

**Pos.4 - Option (Paint)\*\***

omit - no Paint

**P** - Painted

**PC** - Corrosion Protected Paint

**Pos.3 - Output Shaft Extensions\***

**C** - ø25 straight, Parallel key A8x7x32 DIN 6885

**CO** - ø1" straight, Parallel key ¼"x¼"x1¼" BS46

**SH** - ø25,32 splined BS 2059 (SAE 6B)

**SA** - ø24,5 splined B25x22 DIN 5482

**Pos.5 - Design Series**

omit - Factory specified

**ORDER CODE - LBS, LBV**

	1	2	3	4	5	6
<b>LB</b>		/	-			

**Pos.1 - Type**

**S** - Disc Brake for short motor S- MSS

**V** - Disc Brake for very short motor V- MSV

**Pos.4 - Output Shaft Extensions\***

**CB** - ø32 straight, Parallel key A10x8x45 DIN 6885

**KB** - ø35 tapered 1:10, Parallel key B6x6x20 DIN6885

**Pos.2 - Design code**

**289** - for MSS and MSV Motors

**290** - for MSS and MSV Motors (Wheel Mount)

**Pos.5 - Option (Paint)\*\***

omit - no Paint

**P** - Painted

**PC** - Corrosion Protected Paint

**Pos.3 - Static Torque code (See Specification data)**

**21, 32, 43, 63**

**Pos.6 - Design Series**

omit - Factory specified

**NOTES:**

\* The permissible output torque for shafts must not be exceeded! For Max. Torque values see data on page 5 and 8.

\*\* The color is by customer's request.

The Disc Brakes are mangano-phosphatized as standard.

**ATTENTION:**

1. Hydraulic brake is delivered without oil (it is lubricated only).

2. In all brakes, friction discs and separators should be lubricated. Space is filled with 50 ÷ 120 cm<sup>3</sup> [3.05÷7.32 in<sup>3</sup>] mineral oil HLP (DIN 51524) or HM (ISO 6743/4). For LB/288 fill oil after hydraulic motor assembly.

**HYDRAULIC DISC BRAKES  
FOR FLANGE ATTACHMENT TO MTS AND MTV HYDRAULIC MOTORS**

**TYPE LBS/314**

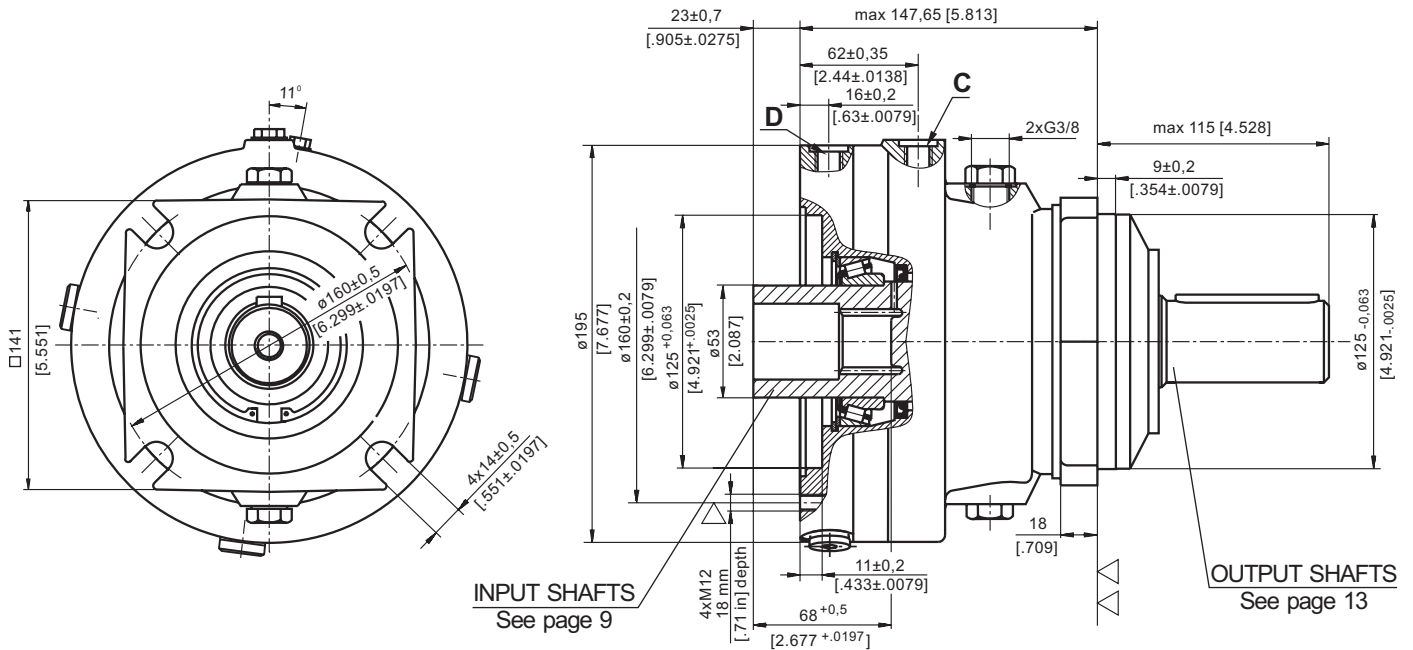

▽ - Place for attachment  
(tightening torque for screw M12x30- 8.8 DIN 912,  
7 daNm [620 lb-in])

▽▽ - Place for attachment

**C** : Brake release Port - G $\frac{1}{4}$ , 12 mm [.47 in] depth  
**D** : Drainage tap - G $\frac{1}{4}$ , 12 mm [.47 in] depth



**TYPE LBV/314**

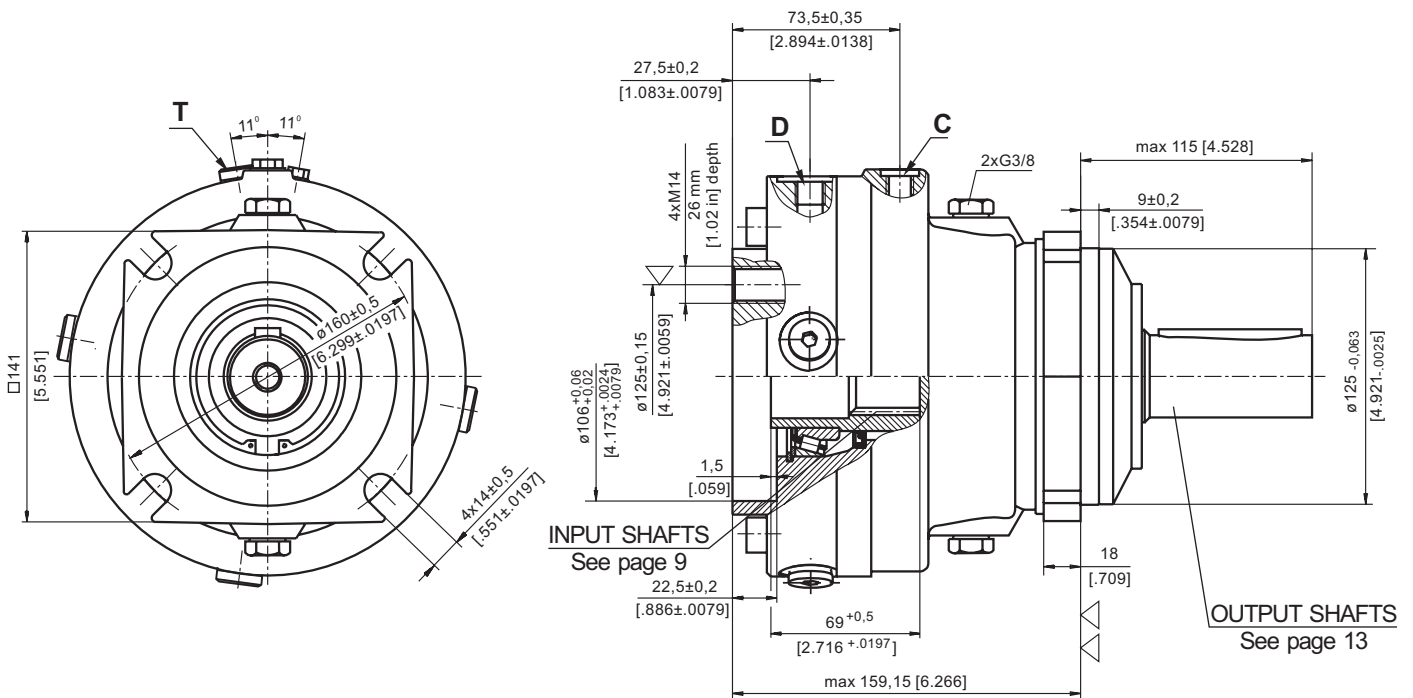

▽ - Place for attachment  
(tightening torque for screw M14 - 8.8 DIN 912,  
11,5 daNm [1020 lb-in])

▽▽ - Place for attachment

**C** : Brake release Port - G $\frac{1}{4}$ , 12 mm [.47 in] depth  
**D, T** : Drainage tap - G $\frac{1}{4}$ , 12 mm [.47 in] depth



**HYDRAULIC DISC BRAKES  
FOR FLANGE ATTACHMENT TO MTS AND MTV HYDRAULIC MOTORS**

**TYPE LBS/315**

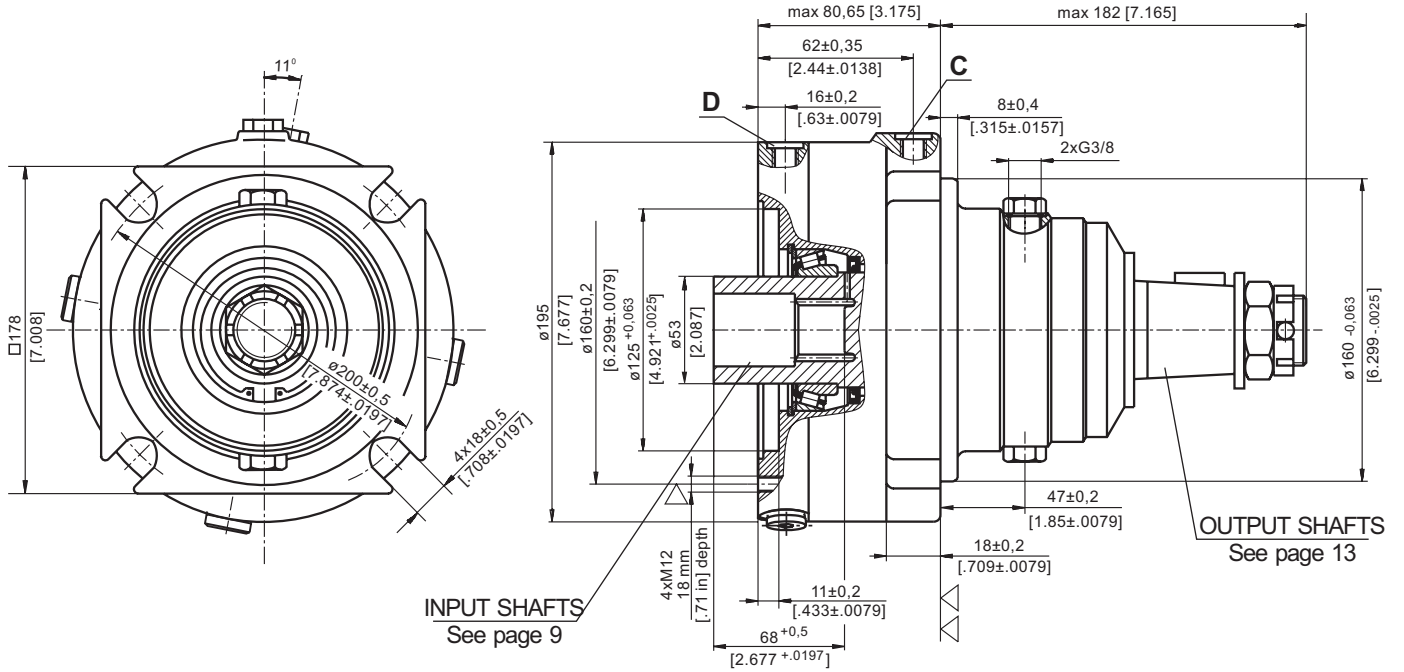

- ▽ - Place for attachment  
(tightening torque for screw M12x30- 8.8 DIN 912,  
7 daNm [620 lb-in])
- ▽▽ - Place for attachment

- C** : Brake release Port - G $\frac{1}{4}$ , 12 mm [.47 in] depth
- D** : Drainage tap - G $\frac{1}{4}$ , 12 mm [.47 in] depth



**TYPE LBV/315**

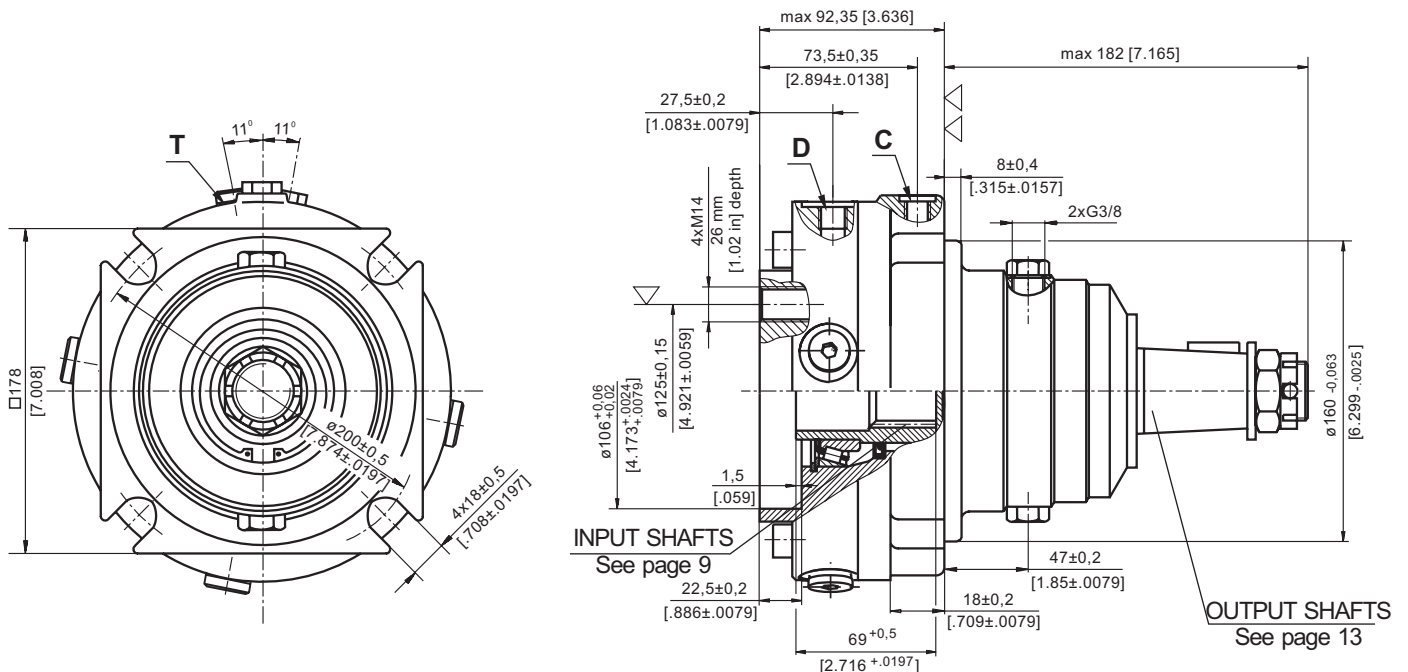

- ▽ - Place for attachment  
(tightening torque for screw M14 - 8.8 DIN 912,  
11,5 daNm [1020 lb-in])
- ▽▽ - Place for attachment

- C** : Brake release Port - G $\frac{1}{4}$ , 12 mm [.47 in] depth
- D, T** : Drainage tap - G $\frac{1}{4}$ , 12 mm [.47 in] depth

**SPECIFICATION DATA**

Description	LBS/314,315	21	29	43	65	85	110	130
*Min. Static Torque, daNm [lb-in]		18-23 [1593-2036]	28-33 [2478-2921]	42-46 [3717-4071]	61-70 [5399-6196]	83-92 [7346-8143]	108-118 [9559-10444]	126-136 [11152-12037]
Opening Pressure bar [PSI]	min**	4-5 [58-72]	6-7 [87-101]	9-10 [130-145]	13-15 [188-217]	18-20 [261-290]	23-25 [333-362]	27-29 [391-420]
	max	300 [4350]						
Min. oil quantity for brake releasing	cm <sup>3</sup> [in <sup>3</sup> ]	8-9 [.488-.549]						
Oil volume	cm <sup>3</sup> [in <sup>3</sup> ]	250						
Max. Pressure in drain space	bar [PSI]	5 [72]						
Weight for .../314 .../315	kg [lb]	24 [52.9]						
		25 [55.1]						

\*Static torque is obtained at working pressure - 0 bar.

\*\*The indicated value is a difference between the inlet pressure for driving of the brake and the drain pressure.

Brakes must always have a drain line

**LOAD CURVE**

**LBS(V) ... /314**

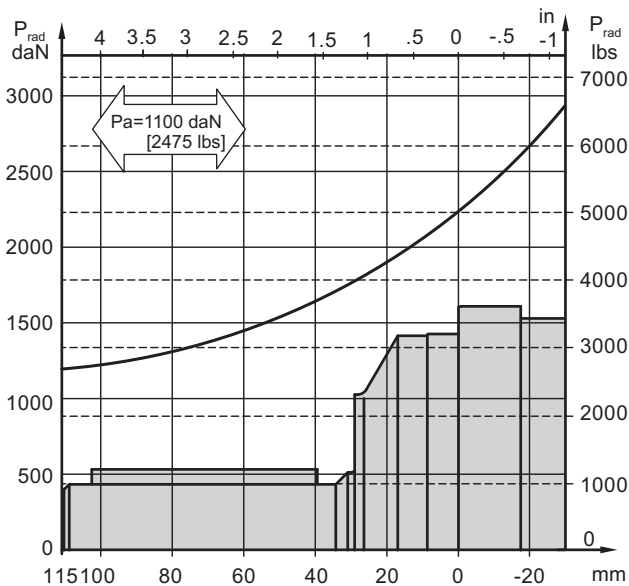

**LBS(V) ... /315**

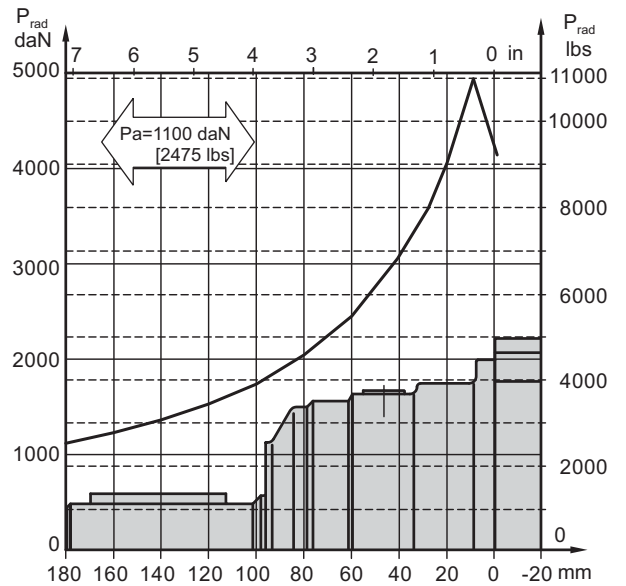

**OUTPUT SHAFT EXTENSIONS**

**C** - $\varnothing 40$  straight, Parallel key A12x8x70 DIN 6885  
Max. Torque 132,8 daNm [11755 In-in]

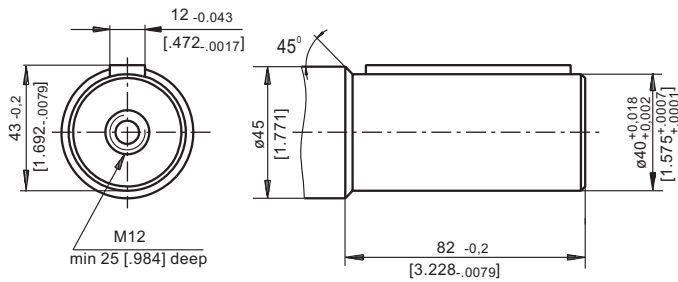

**K** -tapered 1:10, Parallel key B12x8x28 DIN 6885  
Max. Torque 210,7 daNm [18650 lb-in]

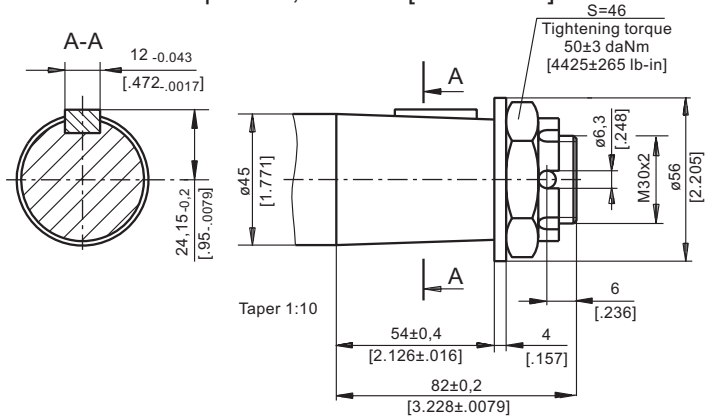

**CO** - $\varnothing 1\frac{1}{2}$ " straight, Parallel key  $\frac{3}{8}$ " x  $\frac{3}{8}$ " x  $2\frac{1}{4}$ " BS46  
Max. Torque 132,8 daNm [11755 In-in]

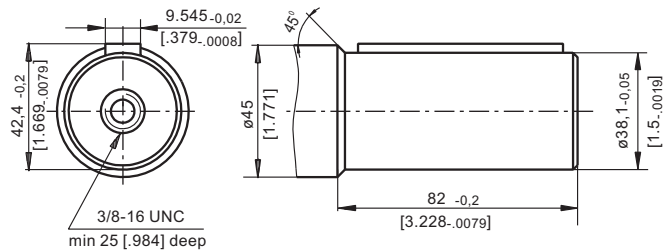

**SH** - $\varnothing 1\frac{1}{2}$ " splined 17T, DP 12/24 ANSI B92.1-1976  
Max. Torque 132,8 daNm [11755 In-in]

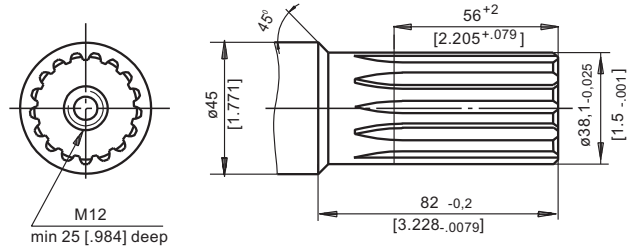

**ORDER CODE**

1	2	3	4	5	6
LB	/	-			

**Pos.1 - Type**

- S** - Disc Brake for short motor **S** - MTS
- V** - Disc Brake for very short motor **V** - MTV

**Pos.2 - Design code**

- 314** - for MTS and MTV Motors
- 315** - for MTS and MTV Motors (Wheel Mount)

**Pos.3 - Static Torque code** (See Specification data)

**21, 29, 43, 65, 85, 110, 130**

**Pos. 4 - Output Shaft Extensions\***

- C** -  $\varnothing 40$  straight, Parallel key A12x8x70 DIN 6885
- CO** -  $\varnothing 1\frac{1}{2}$ " straight, Parallel key  $\frac{3}{8}$ " x  $\frac{3}{8}$ " x  $2\frac{1}{4}$ " BS46
- SH** -  $\varnothing 1\frac{1}{2}$ " splined 17T, ANSI B92.1-1976
- K** -  $\varnothing 45$  tapered 1:10, Parallel key B12x8x28 DIN6885

**Pos. 5 - Option (Paint)\*\***

- omit - no Paint
- P** - Painted
- PC** - Corrosion Protected Paint

**Pos. 6 - Design Series**

- omit - Factory specified

**NOTES:**

- \* The permissible output torque for shafts must not be exceeded!
- \*\* The color is by customer's request.

The Disc Brakes are mangano-phosphatized as standard.

**ATTENTION:**

- Hydraulic brake is delivered without oil (it is lubricated only).
- In all brakes, friction discs and separators should be lubricated. Space is filled with 150÷300 cm<sup>3</sup> [9.15÷18.3 in<sup>3</sup>] mineral oil HLP (DIN 51524) or HM (ISO 6743/4).

**HYDRAULIC DISC BRAKES  
FOR FLANGE ATTACHMENT TO MVS HYDRAULIC MOTORS**

**Type LBS/313**

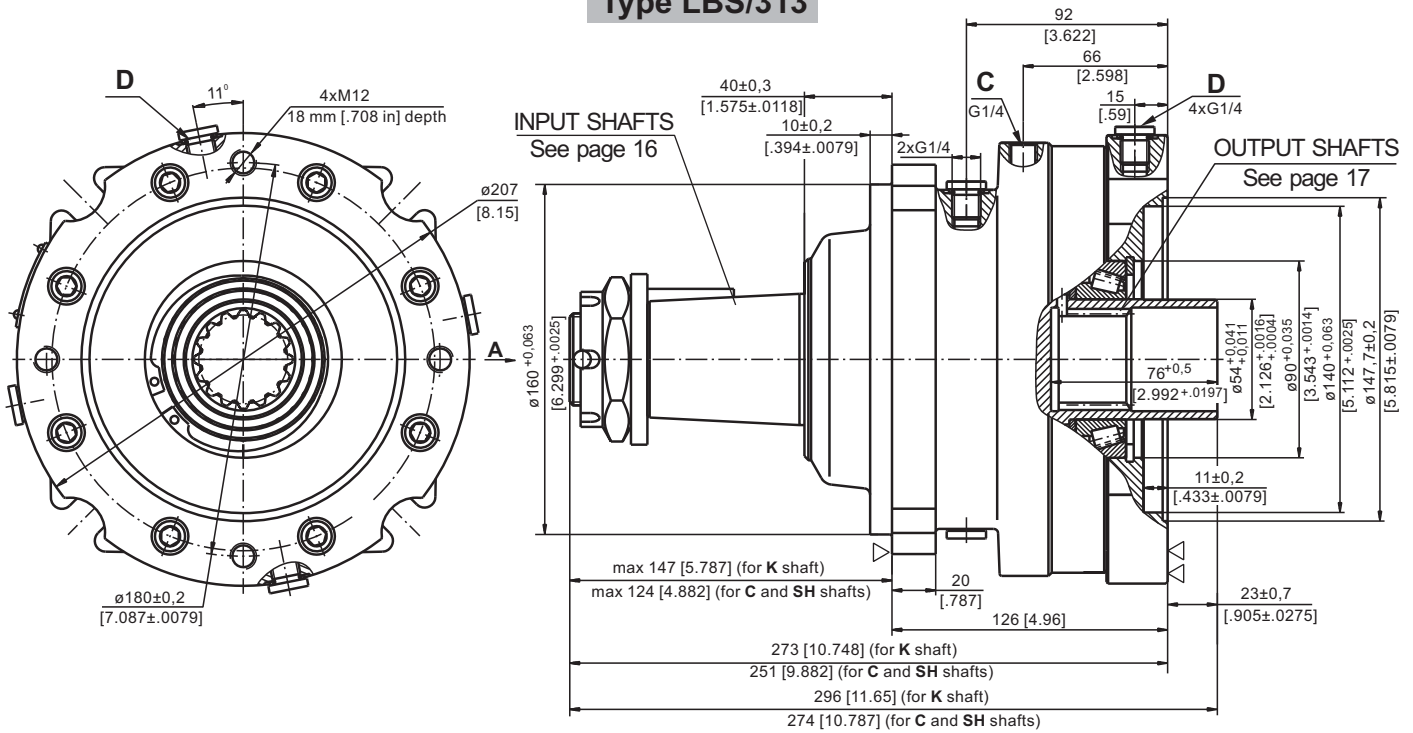

**C :** Brake release Port - G $\frac{1}{4}$ , 12 mm [0.47 in] depth

**D :** Drainage tap - G $\frac{1}{4}$ , 12 mm [0.47 in] depth

▽- Place for attachment

▽▽- Place for attachment  
(tightening torque for screw M12x35 - 8.8 DIN 912,  
7 daNm [620 lb-in])

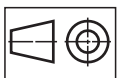
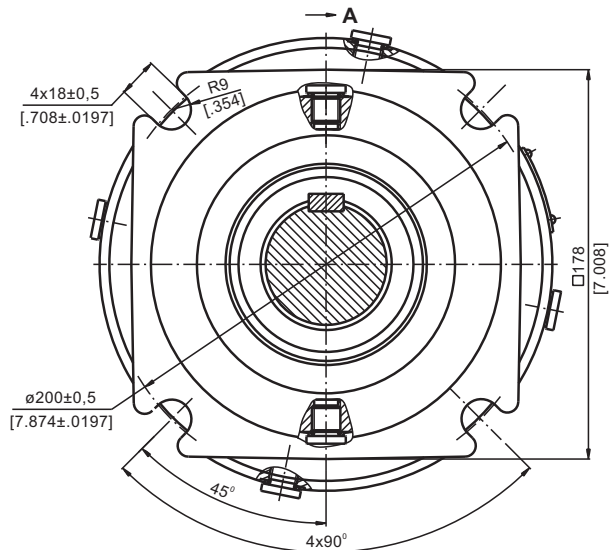

mm [in]

**PERMISSIBLE SHAFT LOADS**

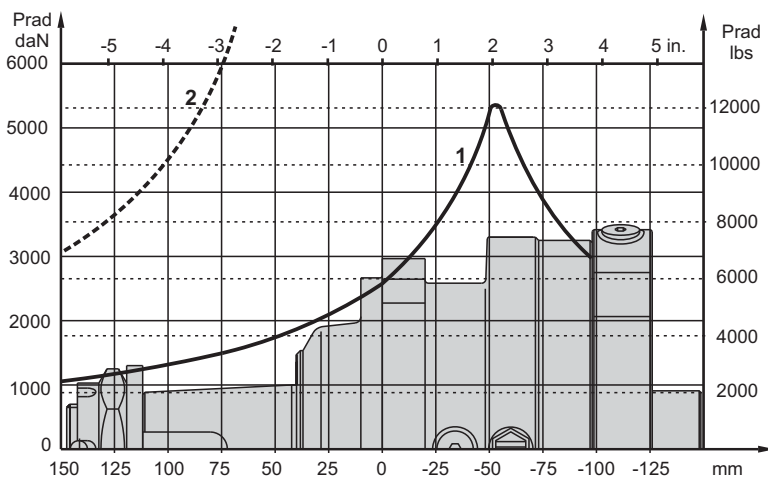

- 1 - Bearing curve:** The curve applies to a B10 bearing life of 3000 hours at 200 RPM.
- 2 - Shaft curve:** The curve represents Max. permissible radial shaft load with safety factor 3:1.

**HYDRAULIC DISC BRAKES  
FOR FLANGE ATTACHMENT TO MVS HYDRAULIC MOTORS**

**Type LBS/316**

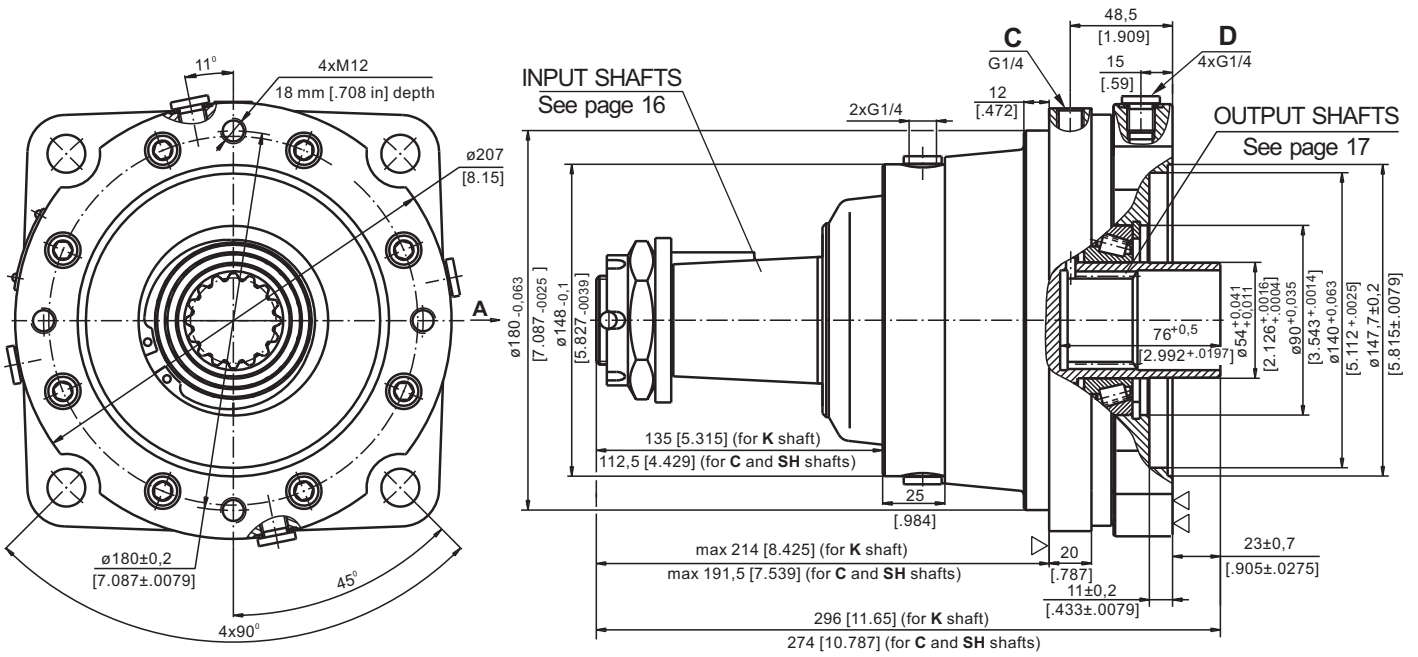

**C** : Brake release Port - G $\frac{1}{4}$ , 12 mm [.47 in] depth

**D** : Drainage tap - G $\frac{1}{4}$ , 12 mm [.47 in] depth

▽ - Place for attachment

▽▽ - Place for attachment  
(tightening torque for screw M12x35 - 8.8 DIN 912,  
7 daNm [620 lb-in])

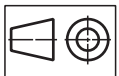
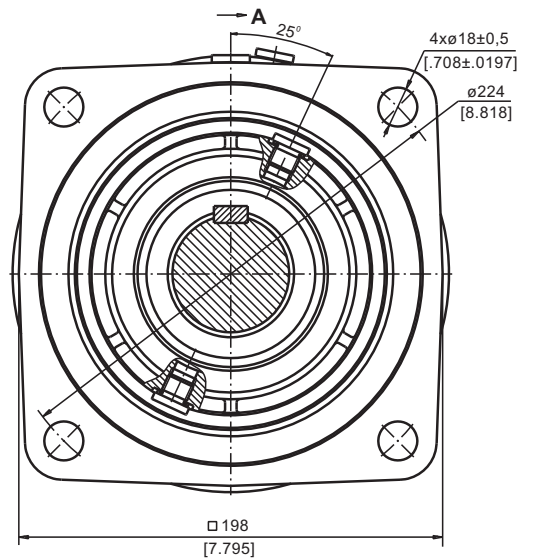

mm [in]

**PERMISSIBLE SHAFT LOADS**

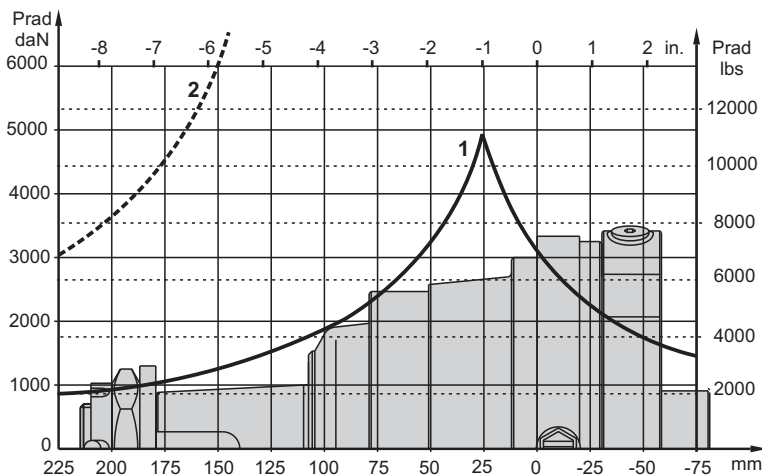

**1** - Bearing curve: The curve applies to a B10 bearing life of 3000 hours at 200 RPM.

**2** - Shaft curve: The curve represents Max. permissible radial shaft load with safety factor 3:1.

**SPECIFICATION DATA**

Description LBS/313,316	21	29	43	65	85	110	130
*Min. Static Torque, daNm [lb-in]	18-23 [1593-2036]	28-33 [2478-2921]	42-47 [3717-4160]	61-71 [5399-6285]	83-94 [7346-8320]	108-118 [9559-10444]	127-137 [11240-12125]
Opening Pressure min** bar [PSI]	4-5 [58-72]	6-7 [87-101]	9-10 [130-145]	13-15 [188-217]	18-20 [261-290]	23-25 [333-362]	27-29 [391-420]
	max 300 [4350]						
Min. oil quantity for brake releasing cm <sup>3</sup> [in <sup>3</sup> ]	8 ÷ 9 [.488 ÷ .549]						
Oil volume cm <sup>3</sup> [in <sup>3</sup> ]	250 [15.25]						
Max. Pressure in drain space bar [PSI]	5 [72]						

\*Static torque is obtained at working pressure - 0 bar.

\*\*The indicated value is a difference between the inlet pressure for driving of the brake and the drain pressure.

Brakes must always have a drain line

**SHAFT EXTENSIONS**

**C** - ø50 straight, Parallel key A14x9x70 DIN 6885

**SH** - ø21/8" splined, 16 DP 8/16 ANS B92.1-1976

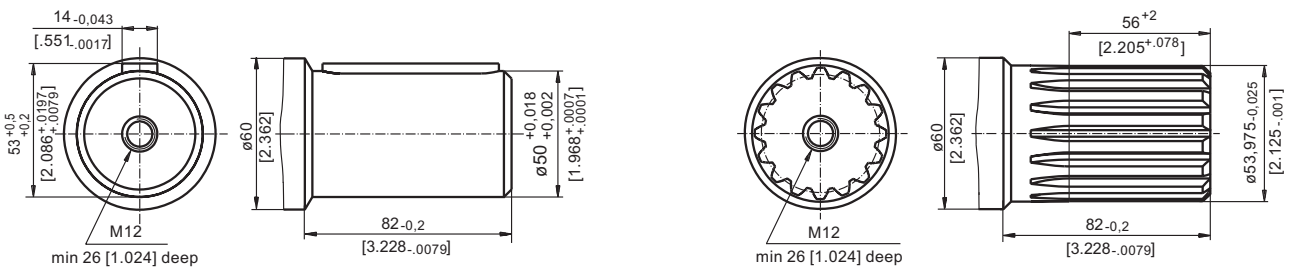

**K** -tapered 1:10, Parallel key B16x10x32 DIN 6885

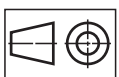
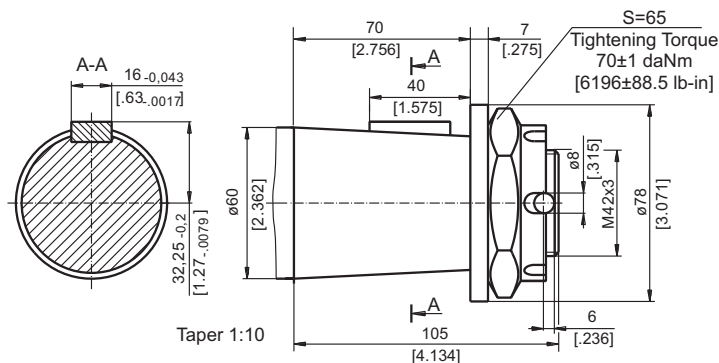

mm [in]



## INTERNAL SPLINE DATA FOR THE ATTACHED COMPONENT

Standard ANS B92.1-1970, class 5  
[ $m=2.54$ ; corrected  $x.m=+1,0$ ]

Fillet Root Side Fit		mm	inch
Number of Teeth	z	16	16
Diametral Pitch	DP	10/20	10/20
Pressure Angle		30°	30°
Pitch Dia.	D	40,640	1.6
Major Dia.	$D_{ri}$	45,2 <sup>+0,4</sup>	1.796÷1.780
Minor Dia.	$D_i$	38,5 <sup>+0,039</sup>	1.5175÷1.516
Space Width [Circular]	$L_o$	5,18±0,037	.2055±.2025
Fillet Radius	R	0,4	.015
Max. Measurement between Pins	L	32,47 <sup>+0,15</sup>	1.284±1.278
Pin Dia.	d	5,6±0,001	.22051±.22043

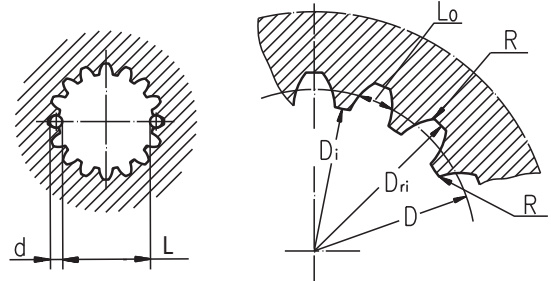

Hardening Specification:  
HV=750±50 on the surface.  
HV=560 at 0,7±0,2 mm [.035±.019in] case depth  
Material: 20 MoCr4 EN 10084 or better.

## ORDER CODE

	1	2	3	4	5
LBS/		-			

## Pos.1 - Designe code

**313** - for MVS Motors

**316** - for MVS Motors (Wheel mount)

## Pos.2 - Static Torque code (See Specification data)

21, 29, 43, 65, 85, 110, 130

## Pos.3 - Output Shaft Extensions\*

**C** - ø50 straight, Parallel key A14x9x70 DIN6885

**SH** - ø2 1/8" splined, ANSI B92.1-1976

**K** - ø60 tapered 1:10, Parallel key B16x10x32 DIN6885

## Pos.4 - Option (Paint)\*\*

omit - no Paint

**P** - Painted

**PC** - Corrosion Protected Paint

## Pos.5 - Design Series

omit - Factory specified

## NOTES:

\* The permissible output torque for shafts must be not exceeded!

\*\* The color is by customer's request.

The Disc Brakes are mangano-phosphatized as standard.

## ATTENTION:

1. Hydraulic brake is delivered without oil (it is lubricated only).

2. In all brakes, friction discs and separators should be lubricated. Space is filled with 150 ÷ 300 cm<sup>3</sup> [9.15 ÷ 18.3 in<sup>3</sup>] mineral oil HLP (DIN 51524) or HM (ISO 6743/4).