

PSQ-PSG

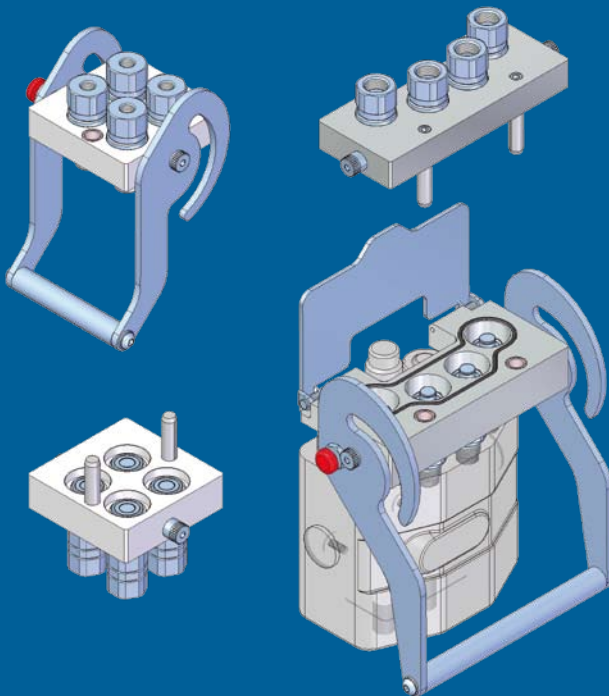

Caratteristiche tecniche

- Intercambiabilità: disegno esclusivo Dnp
- Occlusione: faccia piana
- Aggancio: maniglia con doppia sicura
- Materiale: acciaio e alluminio
- Finitura: Zn-Fe (Cr III)
- Filettature: BSP – NPT – SAE – METRICHE
- Guarnizioni standard: NBR
- Temperatura d'esercizio: -25 °C +100 °C
- Guarnizioni opzionali: FKM, EPDM o altro
- Pressioni di esercizio: 250-350 bar
- Connessione in pressione: consentita (lato piastra mobile)
- Massima pressione residua: pressione d'esercizio

Technical data

- Interchange: exclusiv Dnp profile
- Occlusion: flat face
- Locking: lever with safety devices
- Material: steel and aluminium
- Finishing: Zn-Fe (Cr III)
- Threads: BSP – NPT – SAE – METRIC
- Standard seals: NBR
- Working temperature: -25 °C +100 °C
- Optional seals: FKM, EPDM or more
- Working pressure: 250-350 bar
- Connection under pressure: allowed (mobile part only)
- Max residual pressure: working pressure

Technische Merkmale

- Austauschbarkeit: laut exklusiver Dnp Zeichnung
- Verschluss: flachdichtend
- Kupplung: Hebel mit doppelter Sicherung
- Werkstoff: Stahl und Aluminium
- Ausführung: Zn-Fe (Cr III)
- Gewinde: BSP – NPT – SAE – METRISCHE
- Standard-Dichtungen: NBR
- Betriebstemperatur: -25 °C +100 °C
- Dichtungen nach Wahl: FKM, EPDM, usw.
- Betriebsdruck: 250-350 bar
- Kuppeln unter Druck: erlaubt (nur Loshälfte)
- Max. Restdruck: Betriebsdruck

Caracteristiques techniques

- Intercambiabilité: projet exclusif Dnp
- Obturation: clapet plat
- Accrochage: levier avec double sécurité
- Matériel: acier et aluminium
- Traitement: Zn-Fe (Cr III)
- Taraudage: BSP – NPT – SAE – METRIQUES
- Joints standard: NBR
- Température de service: -25 °C +100 °C
- Joints facultatifs: FKM, EPDM, ect.
- Pression de service: 250-350 bar
- Connexion sous pression: possible (seulement partie mobile)
- Pression restante max: pression de service

Nominal size	Max working pressure	Rated flow	Max flow rate	Min burst pressure			Fluid spillage
				Male	Female	Coupled	
DNP BG ISO mm	Mpa	l/min	l/min	MPa	MPa	MPa	cc
PSQ 13 2 10 8,6	35	23	45	140	170	140	0,006
PSG 13 2 10 8,6	25	23	45	140	100	100	0,006

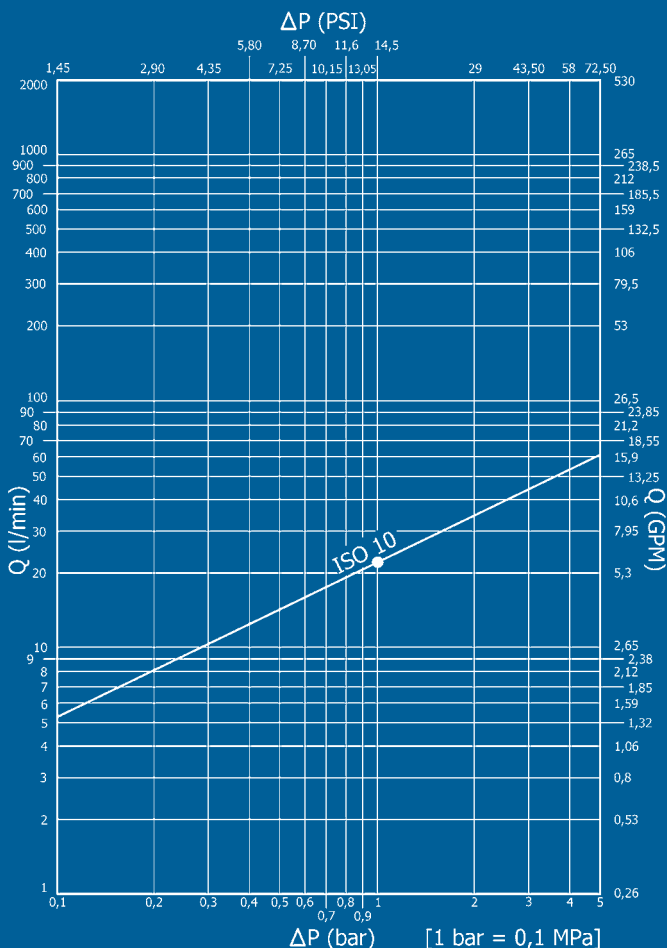

E

D

F

PSQ2 DN13 - BG 2 - ISO 10

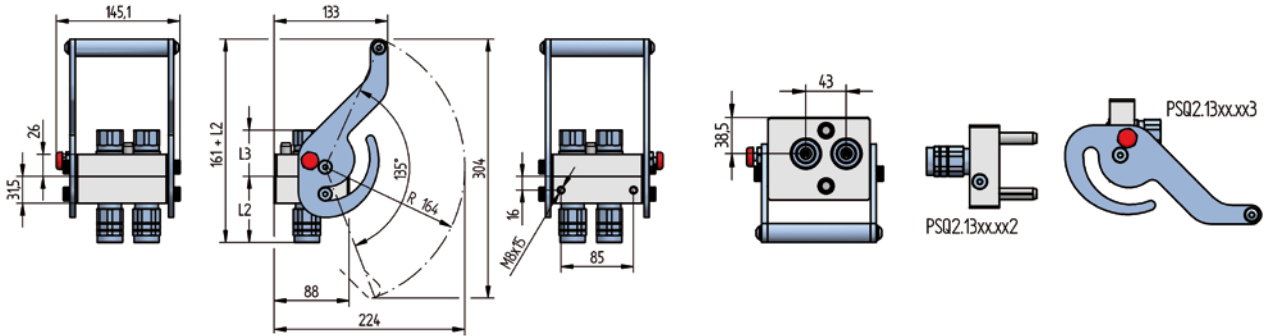

THREADS	L2	L3	L4	F	NORMA	PARTE FISSA-FIXED PART-FEST HÄLFTE-PARTIE FIXE			PARTE MOBILE-MOBILE PART-LOSHÄLFTE-PARTIE MOBILE		
						COUPLING (F)	PART (F)	Weight (g)	COUPLING (M)	PART (M)	Weight (g)
IG 1	77,5	54,1		BSP 1/4"	DIN 3852-2-X	POT4.1306.112	PSQ2.1306.002	1410	POT4.1306.113	PSQ2.1306.003	2326
	77,5	54,1		BSP 3/8"	DIN 3852-2-X	POT4.1310.112	PSQ2.1310.002	1390	POT4.1310.113	PSQ2.1310.003	2306
	77,5	57,6		NPT 3/8"	ANSI B1.20.3	POT4.1310.012	PSQ2.1310.012	1400	POT4.1310.013	PSQ2.1310.013	2330
	77,5	54,1		BSP 1/2"	DIN 3852-2-X	POT4.1313.112	PSQ2.1313.002	1360	POT4.1313.113	PSQ2.1313.003	2254
	77,5	58,1		NPT 1/2"	ANSI B1.20.3	POT4.1313.012	PSQ2.1313.012	1370	POT4.1313.013	PSQ2.1313.013	2305
	77,5	54,1		M16x1,5	ISO 6149-1	POT4.1316.102	PSQ2.1316.102	1390	POT4.1316.103	PSQ2.1316.103	2287
	77,5	54,1		M18x1,5	ISO 6149-1	POT4.1318.102	PSQ2.1318.102	1380	POT4.1318.103	PSQ2.1318.103	2273
IG 2	76	55,1		9/16"-18 UNF 2B	SAE J 1926-1	POT4.1315.032	PSQ2.1315.032	1390	POT4.1315.033	PSQ2.1315.033	2293
	77,5	55,1		3/4"-16 UNF 2B	SAE J 1926-1	POT4.1319.032	PSQ2.1319.032	1370	POT4.1319.033	PSQ2.1319.033	2283
	78,5	55,1		M22x1,5	SAE J 2244/1	POT4.1322.102	PSQ2.1322.102	1350	POT4.1322.103	PSQ2.1322.103	2257
AG 5	79	55,1	13	BSP 1/2"	BS B5200	POT4.1313.702	PSQ2.1313.702	1330	POT4.1313.703	PSQ2.1313.703	2235

PSQ4 DN13 - BG 2 - ISO 10

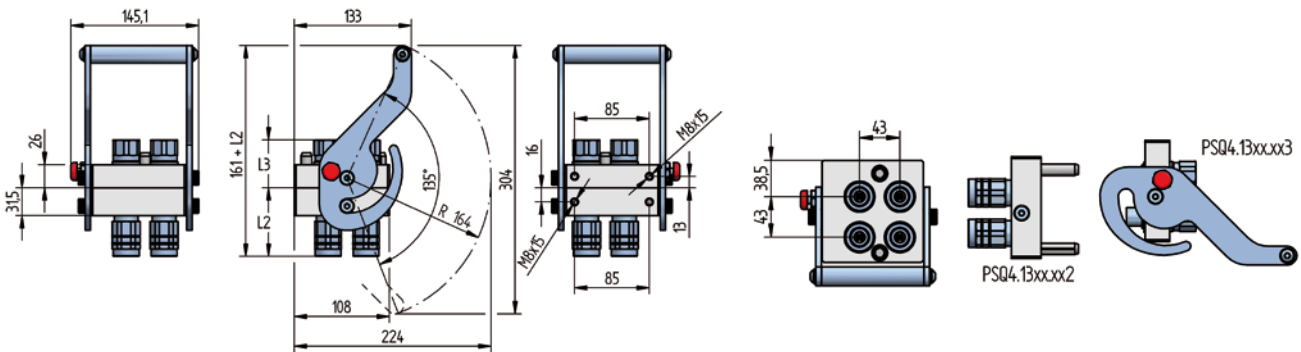

THREADS	L2	L3	L4	F	NORMA	PARTE FISSA-FIXED PART-FEST HÄLFTE-PARTIE FIXE			PARTE MOBILE-MOBILE PART-LOSHÄLFTE-PARTIE MOBILE		
						COUPLING (F)	PART (F)	Weight (g)	COUPLING F	PART (F)	Weight (g)
IG 1	77,5	54,1		BSP 1/4"	DIN 3852-2-X	POT4.1306.112	PSQ4.1306.002	2040	POT4.1306.113	PSQ4.1306.003	2900
	77,5	54,1		BSP 3/8"	DIN 3852-2-X	POT4.1310.112	PSQ4.1310.002	2000	POT4.1310.113	PSQ4.1310.003	2860
	77,5	57,6		NPT 3/8"	ANSI B1.20.3	POT4.1310.012	PSQ4.1310.012	2000	POT4.1310.013	PSQ4.1310.013	2880
	77,5	54,1		BSP 1/2"	DIN 3852-2-X	POT4.1313.112	PSQ4.1313.002	1940	POT4.1313.113	PSQ4.1313.003	2810
	77,5	58,1		NPT 1/2"	ANSI B1.20.3	POT4.1313.012	PSQ4.1313.012	1950	POT4.1313.013	PSQ4.1313.013	2820
	77,5	54,1		M16x1,5	ISO 6149-1	POT4.1316.102	PSQ4.1316.102	2010	POT4.1316.103	PSQ4.1316.103	2800
	77,5	54,1		M18x1,5	ISO 6149-1	POT4.1318.102	PSQ4.1318.102	1980	POT4.1318.103	PSQ4.1318.103	2770
IG 2	76	55,1		9/16"-18 UNF 2B	SAE J 1926-1	POT4.1315.032	PSQ4.1315.032	2000	POT4.1315.033	PSQ4.1315.033	2810
	77,5	55,1		3/4"-16 UNF 2B	SAE J 1926-1	POT4.1319.032	PSQ4.1319.032	1960	POT4.1319.033	PSQ4.1319.033	2790
	78,5	55,1		M22x1,5	SAE J 2244/1	POT4.1322.102	PSQ4.1322.102	1920	POT4.1322.103	PSQ4.1322.103	2740
AG 5	79	55,1	13	BSP 1/2"	BS B5200	POT4.1313.702	PSQ4.1313.702	1940	POT4.1313.703	PSQ4.1313.703	2810

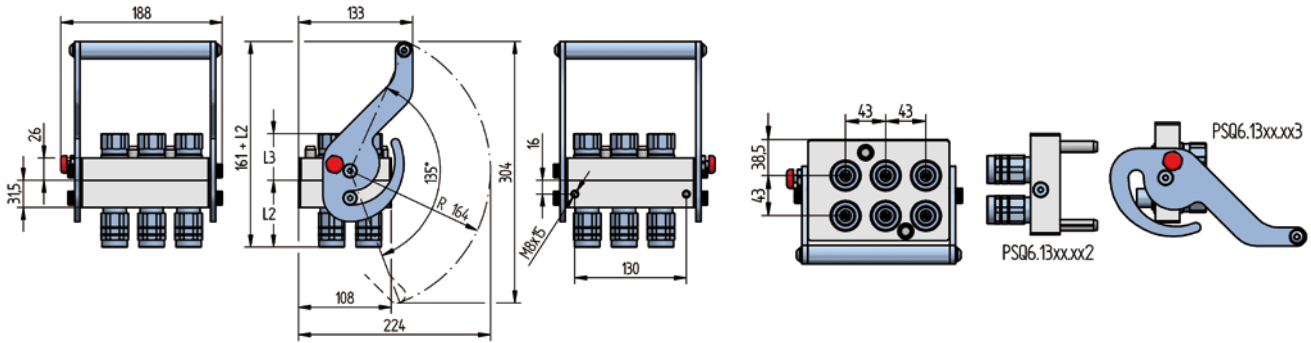
PSQ6 DN13 - BG 2 - ISO 10

THREADS	L2	L3	L4	F	NORMA	PARTE FISSA-FIXED PART-FEST HÄLFTE-PARTIE FIXE			PARTE MOBILE-MOBILE PART-LOSHÄLFTE-PARTIE MOBILE		
						COUPLING (F)	PART (F)	Weight (g)	COUPLING (M)	PART (M)	Weight (g)
IG 1	77,5	54,1		BSP 1/4"	DIN 3852-2-X	POT4.1306.112	PSQ6.1306.002	2850	POT4.1306.113	PSQ6.1306.003	3740
	77,5	54,1		BSP 3/8"	DIN 3852-2-X	POT4.1310.112	PSQ6.1310.002	2790	POT4.1310.113	PSQ6.1310.003	3680
	77,5	57,6		NPT 3/8"	ANSI B1.20.3	POT4.1310.012	PSQ6.1310.012	2800	POT4.1310.013	PSQ6.1310.013	3700
	77,5	54,1		BSP 1/2"	DIN 3852-2-X	POT4.1313.112	PSQ6.1313.002	2700	POT4.1313.113	PSQ6.1313.003	3600
	77,5	58,1		NPT 1/2"	ANSI B1.20.3	POT4.1313.012	PSQ6.1313.012	2720	POT4.1313.013	PSQ6.1313.013	3620
	77,5	54,1		M16x1,5	ISO 6149-1	POT4.1316.102	PSQ6.1316.102	2810	POT4.1316.103	PSQ6.1316.103	3580
	77,5	54,1		M18x1,5	ISO 6149-1	POT4.1318.102	PSQ6.1318.102	2770	POT4.1318.103	PSQ6.1318.103	3540
IG 2	76	55,1		9/16"-18 UNF 2B	SAE J 1926-1	POT4.1315.032	PSQ6.1315.032	2790	POT4.1315.033	PSQ6.1315.033	3600
	77,5	55,1		3/4"-16 UNF 2B	SAE J 1926-1	POT4.1319.032	PSQ6.1319.032	2740	POT4.1319.033	PSQ6.1319.033	3570
	78,5	55,1		M22x1,5	SAE J 2244/1	POT4.1322.102	PSQ6.1322.102	2690	POT4.1322.103	PSQ6.1322.103	3490
AG 5	79	55,1	13	BSP 1/2"	BS B5200	POT4.1313.702	PSQ6.1313.702	2700	POT4.1313.703	PSQ6.1313.703	3600

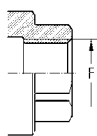
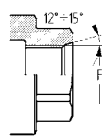
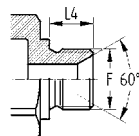
THREADS

IG 1

IG 2

AG 5

METAL



SPSQ.220



SPSQ.240

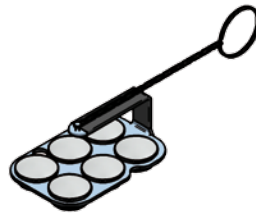

SPSQ.260

FIXED PART CAP		
PART (F)	CODE	Weight (g)
PSQ2.13xx.xx2	SPSQ.220	189
PSQ4.13xx.xx2	SPSQ.240	286
PSQ6.13xx.xx2	SPSQ.260	386

PARTI DI RICAMBIO / SPARE PARTS / ERSATZTEILE / PIECES DE RECHANGE

