



Series 1700 - Electronic proportional regulators

General

Modern industrial applications require increasingly high performances from their pneumatic components. For example, the speed and thrust of a pneumatic actuator may need to be varied. These parameters often need to be modified dynamically while an operation is running.

This solution can be achieved by means of a regulator that can vary pressure over time.

Pneumax portfolio includes 1700 Series electronic proportional regulator, available in three different sizes with flow rates of 7, 1100, and 4000 NI/min respectively and supporting Analog/Digital, CANopen® or IO-Link communication interfaces.

Application fields

Typical applications will include the necessity to dynamically control the force of the actuator, be it thrust or torque.

Examples include: Closing systems, painting systems, tensioning systems, packaging systems, pneumatic braking systems, force control for welding grippers, thickness compensation systems, balancing systems, laser cutting, pressure transducers for the control of modulating valves, test benches for system testing, force control for buffers on polishers, etc.

Product presentation

The supply and exhaust connections are on one side of the regulator and the working port is on the opposite side. The two remaining sides carry G 1/8" ports that are blanked off with removable plugs, these can be used to connect a pressure gauge or as an outlet port. If you order the version with the external feedback there is a M5 threaded connection to which connect the feedback pressure (to the pressure transducer). This connection is placed on the outlet connection side. This option allows to take the signal from a remote point instead of directly from the outlet connection; this function is typically used when the regulated pressure is used far away from the regulator. The control solenoid valves, the pressure sensor, and the management electronics are placed in upper part of the regulator. The electronic management system is the same for all the size 0, size 1 and size 3 regulators.

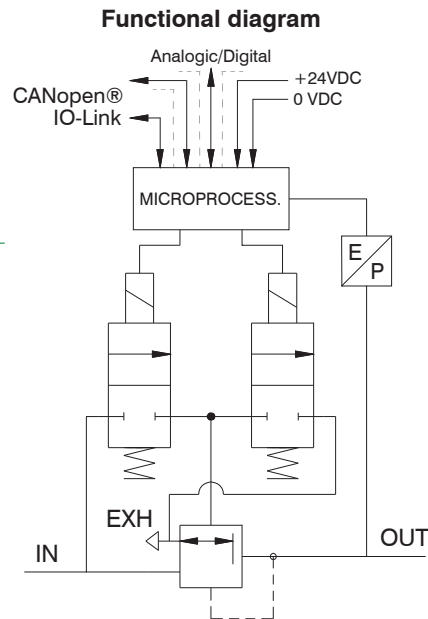

CLOSED LOOP diagram (internal control circuit)

The proportional regulator is known as a CLOSED LOOP regulator because a pressure transducer in the circuit transmits a continuous analog signal to the microprocessor, which compares the reference value and supplies the control solenoid valves accordingly.

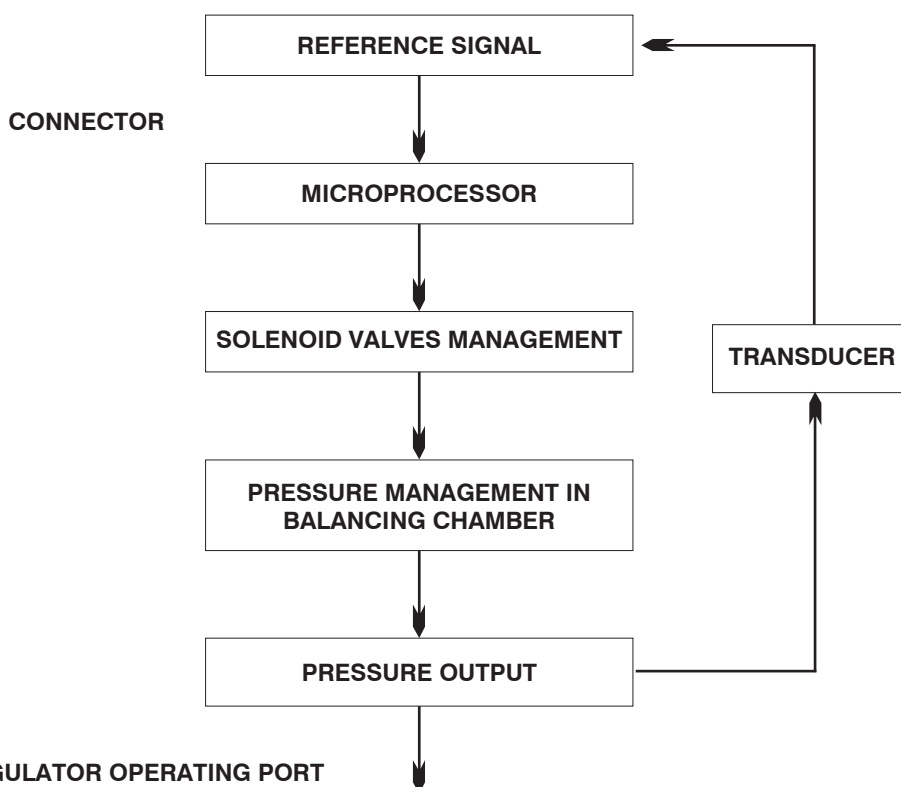

2 AIR SERVICE UNITS



Features

Pneumatic

Fluid	Air filtered at 5 micron and dehumidified		
Minimum inlet pressure	Desired outlet pressure + 1 bar		
Maximum inlet pressure	10 bar		
Outlet pressure	0 ÷ 9 bar		
Nominal flowrate from 1 to 2 (6 bar ΔP 1 bar)	Size 0	Size 1	Size 3
	7 NI/min	1100 NI/min	4000 NI/min
Discharge flowrate (a 6 bar with 1 bar overpressure)	7 NI/min	1300 NI/min	4500 NI/min
Air consumption	< 1 NI/min	< 1 NI/min	< 1 NI/min
Supply connection	M5	G 1/4"	G 1/2"
Operating connection	M5	G 1/4"	G 1/2"
Exhaust connection	Ø1,8	G 1/8"	G 3/8"
Maximum fitting tightening	3 Nm	15 Nm	15 Nm

Electric

Supply voltage	24VDC ± 10% (stabilized with ripple < 1%)	
Standby current consumption	70mA	
Current consumption with solenoid valves on	400mA	
**Reference Signal	Voltage	*0 ÷ 10 V *0 ÷ 5 V *1 ÷ 5 V
	Current	*4 ÷ 20 mA *0 ÷ 20 mA
**Input Impedance	Voltage	10 kΩ
	Current	250 Ω
**Digital Inputs	24VDC ± 10%	
**Digital Output	24 VDC PNP (max current 50 mA)	

Functional

Linearity	± Insensitivity
Hysteresis	± Insensitivity
Repeatability	± Insensitivity
Sensitivity	0,01 bar
Assembly position	Indifferent
Protection grade	IP65 (with casing fitted)
Ambient temperature	-5° ÷ 50° / 23°F ÷ 122°F

Constructional

Body	Anodized aluminum		
Shutters	Brass with vulcanized NBR		
Diaphragm	Cloth-covered rubber		
Seals	NBR		
Cover for electrical part	Technopolymer		
Springs	AISI 302		
Weight	Size 0	Size 1	Size 3
	168 gr.	360 gr.	850 gr.

* Selectable by keyboard or by RS-232

** Valid only for devices with analog input



Overall dimensions ("521" standard version and CANopen® version with SUB-D 15 poles)

Size 0

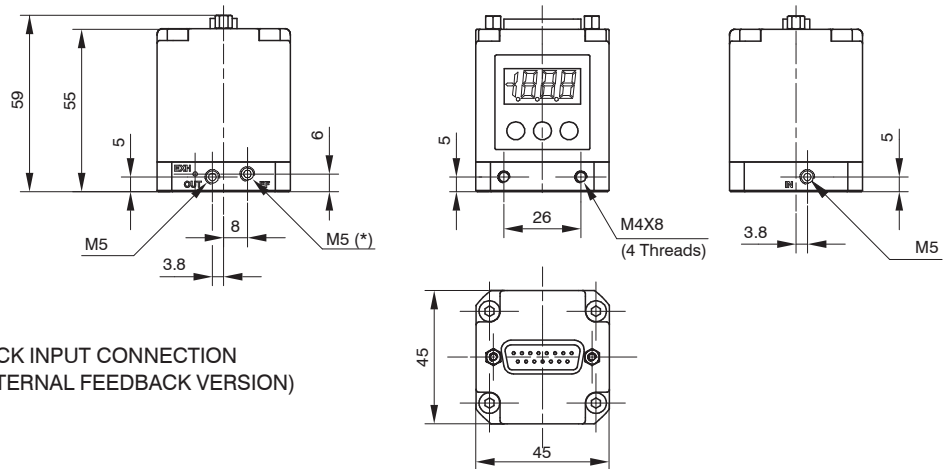

* = EXTERNAL FEEDBACK INPUT CONNECTION
(AVAILABLE ONLY ON THE EXTERNAL FEEDBACK VERSION)

Size 1

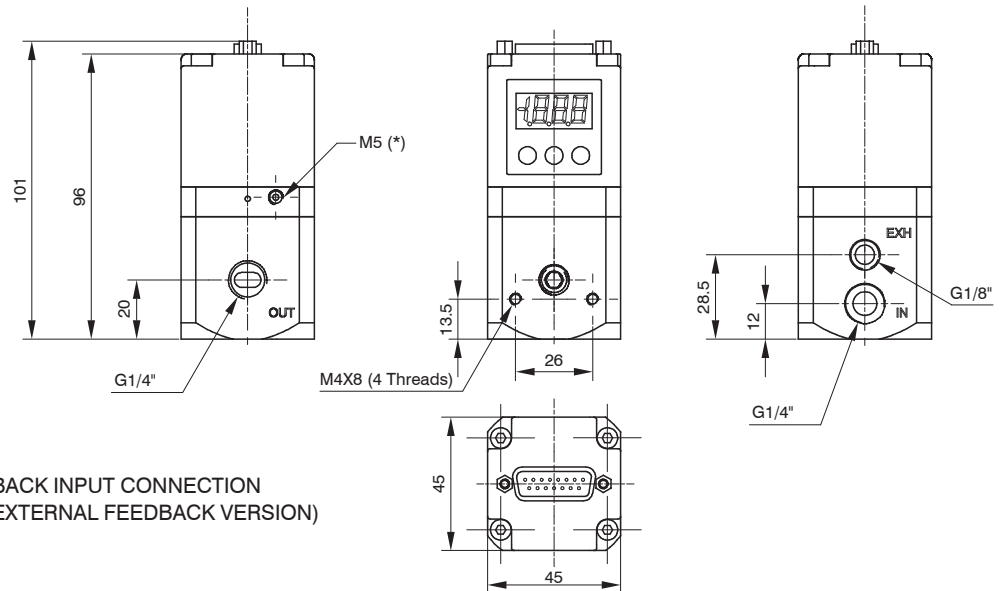

* = EXTERNAL FEEDBACK INPUT CONNECTION
(AVAILABLE ONLY ON THE EXTERNAL FEEDBACK VERSION)

Size 3

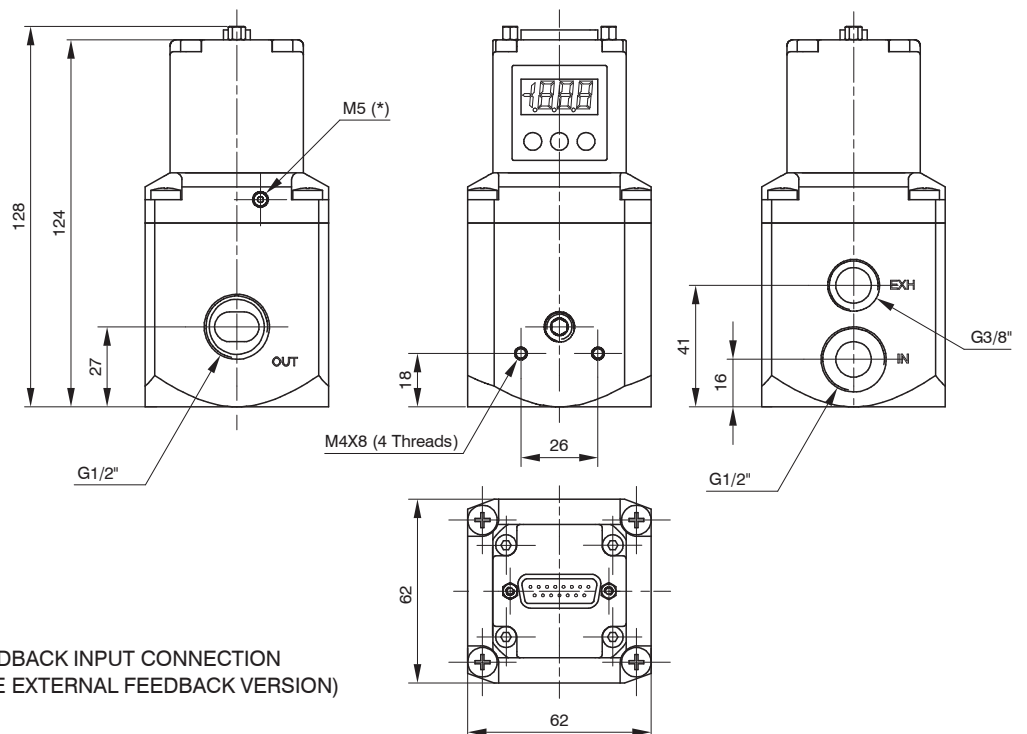

* = EXTERNAL FEEDBACK INPUT CONNECTION
(AVAILABLE ONLY ON THE EXTERNAL FEEDBACK VERSION)

2 AIR SERVICE UNITS

Mounting options ("521" standard version and CANopen® version with SUB-D 15 poles)

In addition to mounting directly using the M4 tappings on the body, the 170M5 bracket may also be used, as shown below:

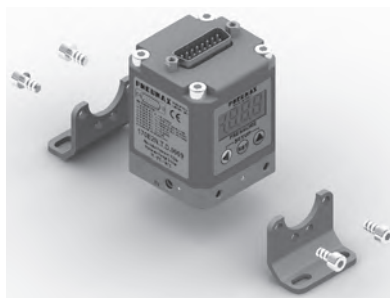
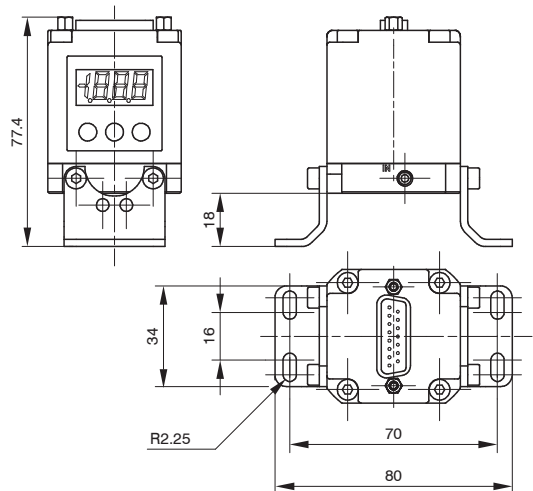

Size 0

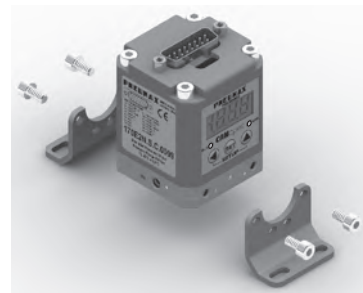

Size 1

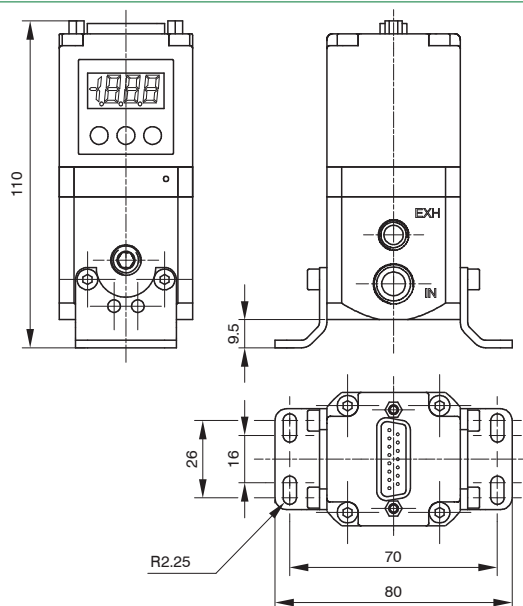
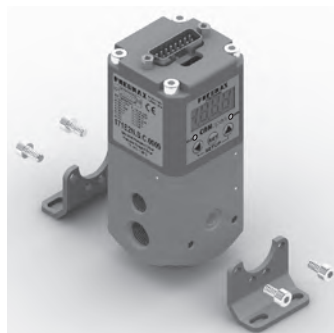

Size 3

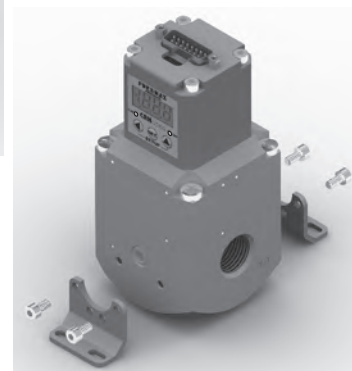
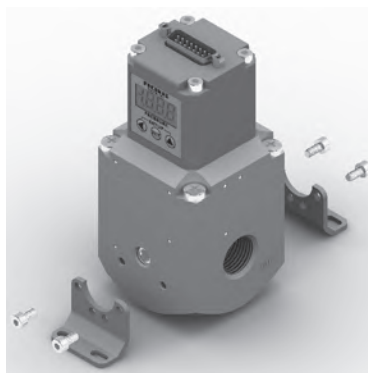
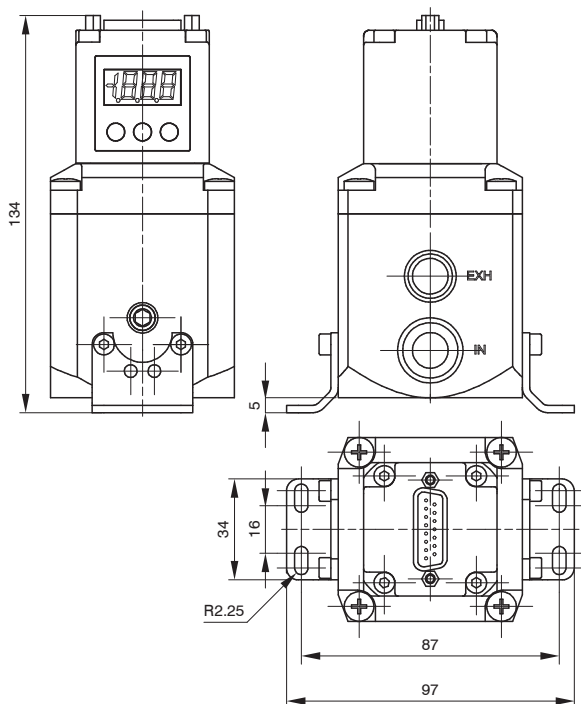

Overall dimensions ("521 M12 version" - CANopen® version)

Size 0

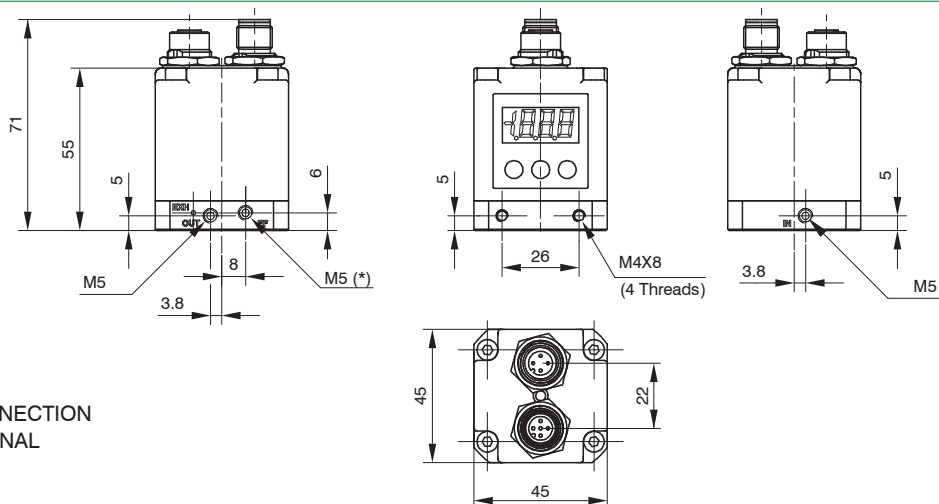

* = EXTERNAL FEEDBACK INPUT CONNECTION
(AVAILABLE ONLY ON THE EXTERNAL FEEDBACK VERSION)

Size 1

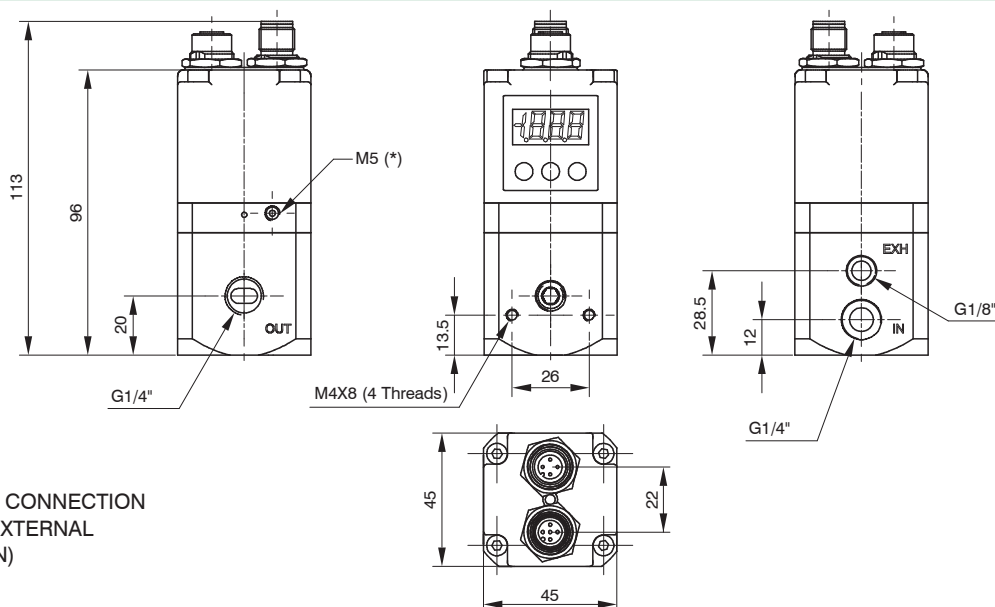

* = EXTERNAL FEEDBACK INPUT CONNECTION
(AVAILABLE ONLY ON THE EXTERNAL FEEDBACK VERSION)

Size 3

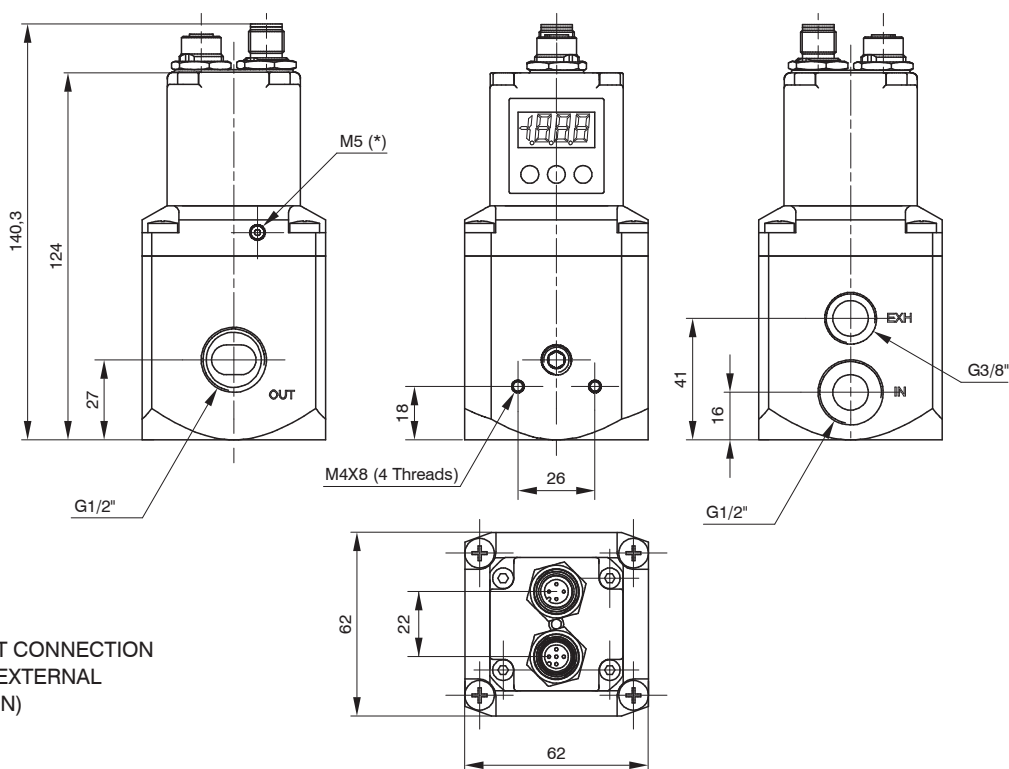

* = EXTERNAL FEEDBACK INPUT CONNECTION
(AVAILABLE ONLY ON THE EXTERNAL FEEDBACK VERSION)

2 AIR SERVICE UNITS

Mounting options ("521 M12 version" - CANopen® version)

In addition to mounting directly using the M4 tapping on the body, the 170M5 bracket may also be used, as shown below:

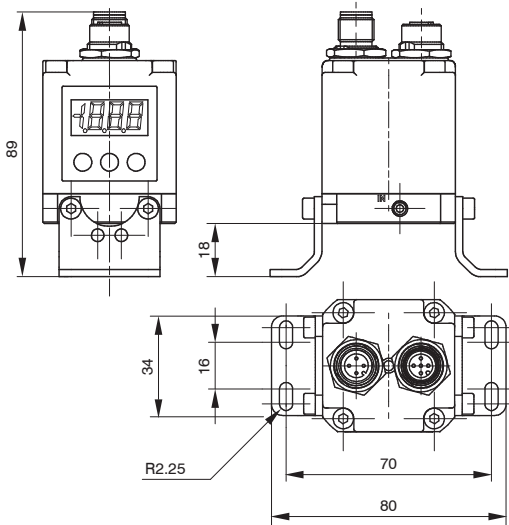

Size 0

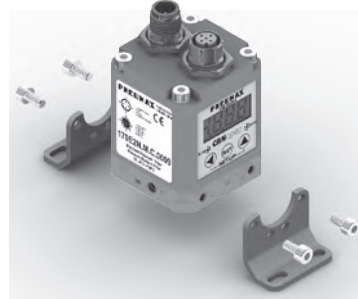

Size 1

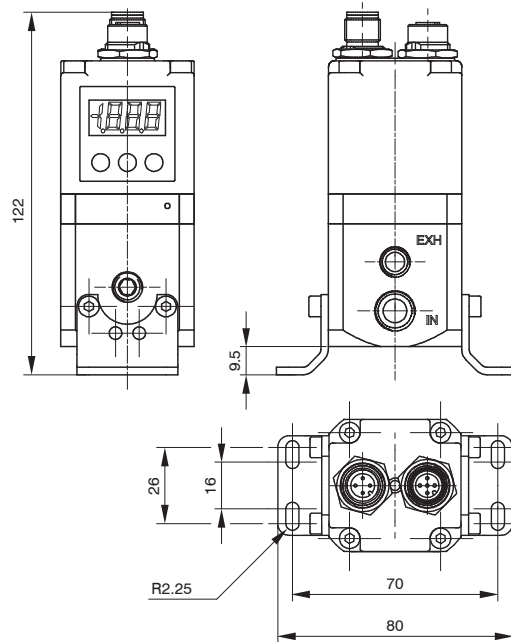

Size 3

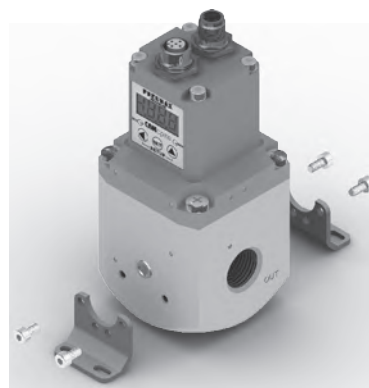
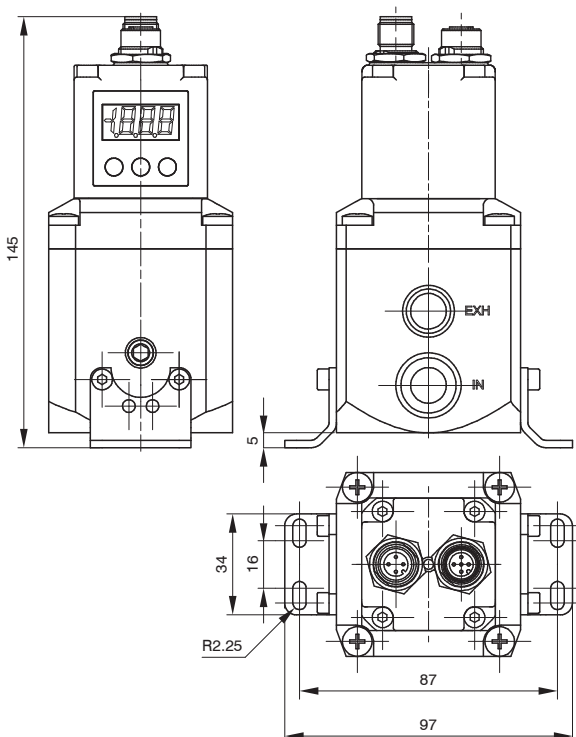

Overall dimensions ("521 M12 BASIC version")

Size 0

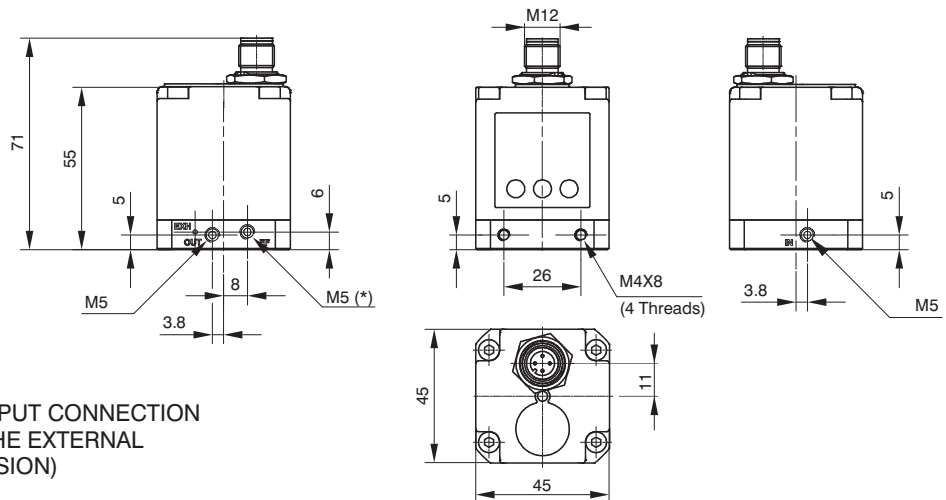

* = EXTERNAL FEEDBACK INPUT CONNECTION
(AVAILABLE ONLY ON THE EXTERNAL
FEEDBACK VERSION)

Size 1

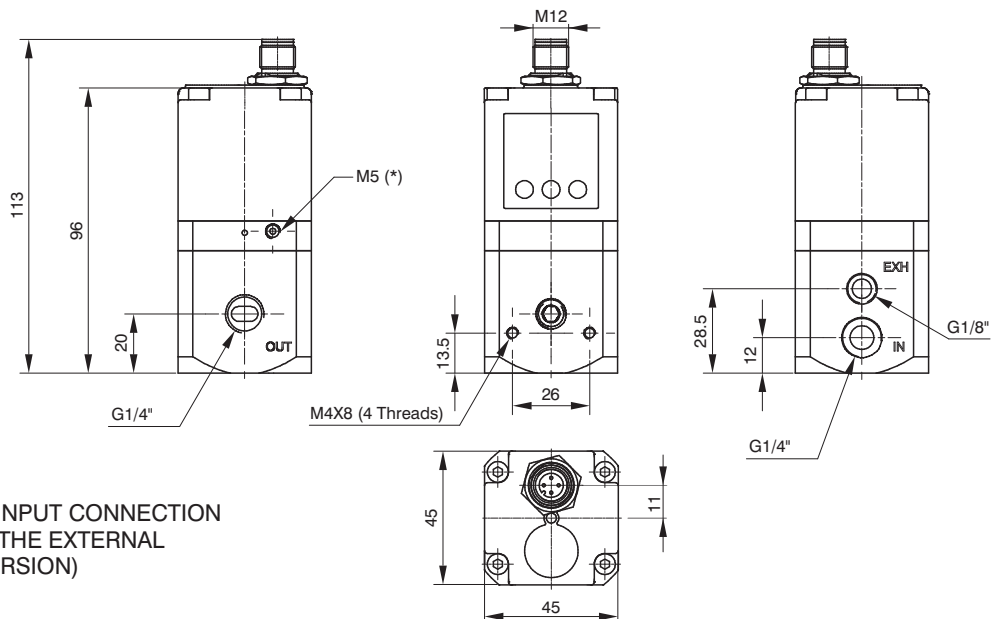

* = EXTERNAL FEEDBACK INPUT CONNECTION
(AVAILABLE ONLY ON THE EXTERNAL
FEEDBACK VERSION)

Size 3

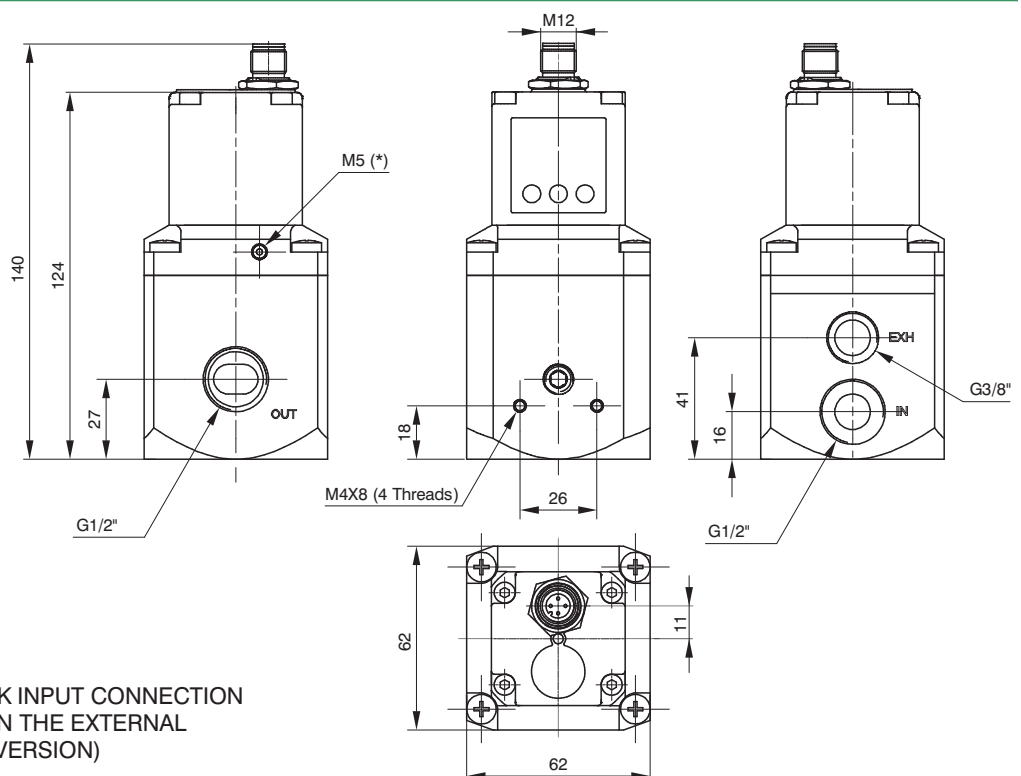

* = EXTERNAL FEEDBACK INPUT CONNECTION
(AVAILABLE ONLY ON THE EXTERNAL
FEEDBACK VERSION)

2 AIR SERVICE UNITS

Mounting options ("521 M12 BASIC version")

In addition to mounting directly using the M4 tapping on the body, the 170M5 bracket may also be used, as shown below:

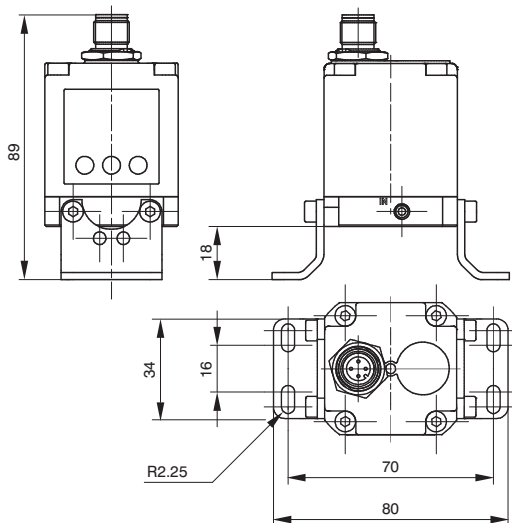

Size 0



Size 1

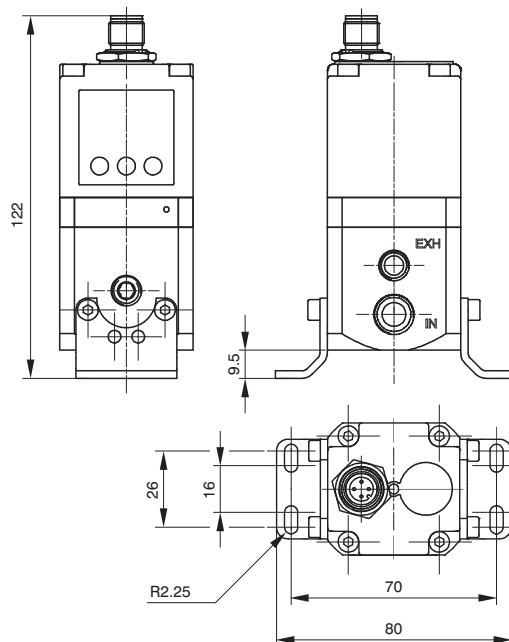

Size 3

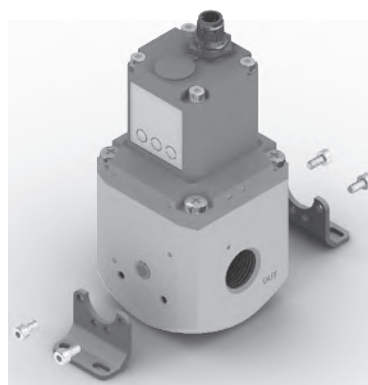
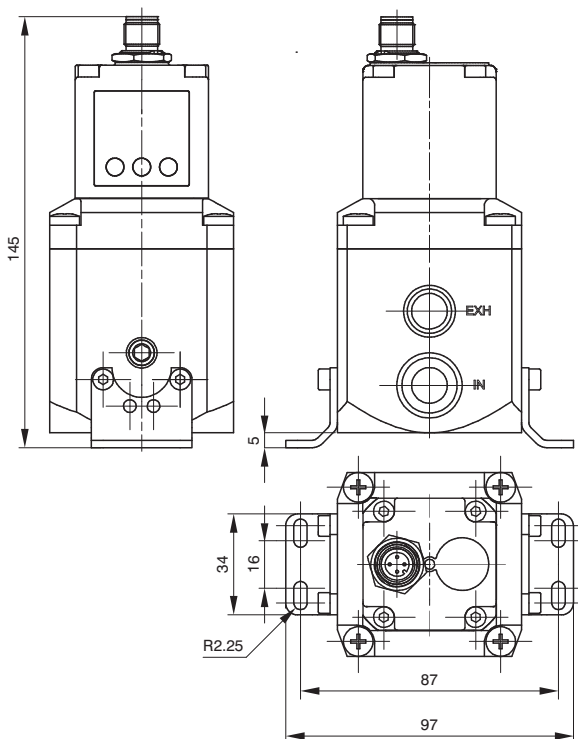

Overall dimensions ("521 M12 version" - Standard version)

Size 0

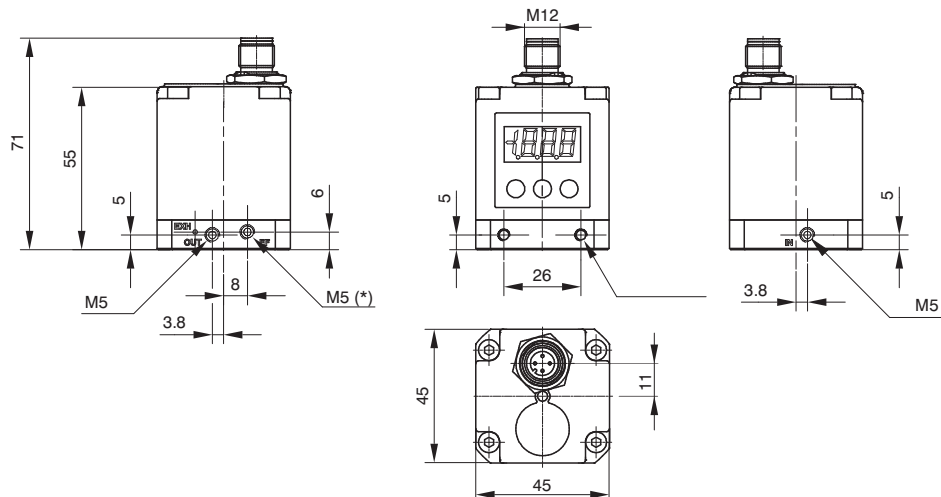

Size 1

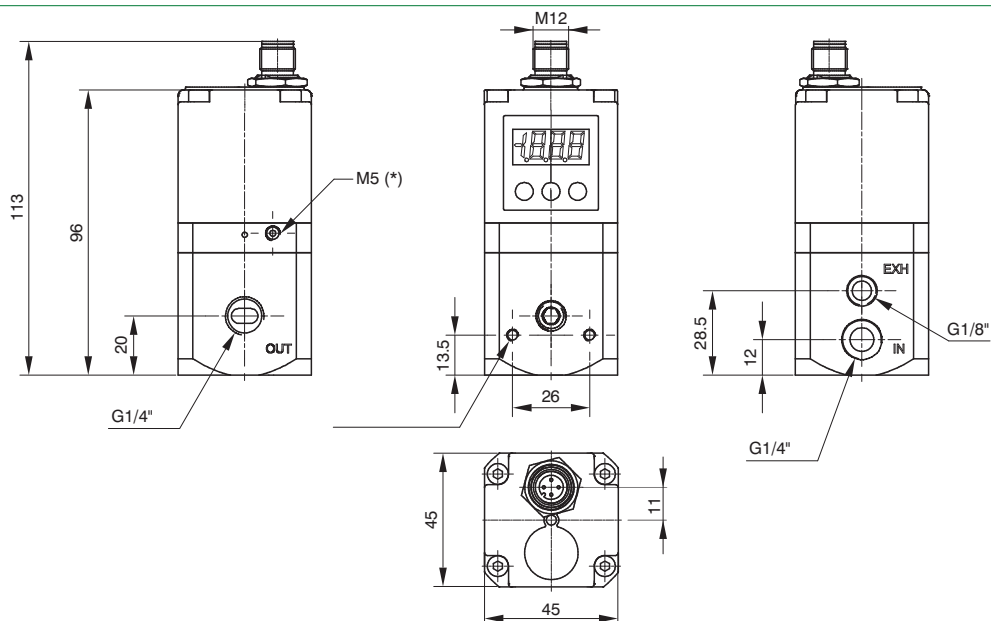

Size 3

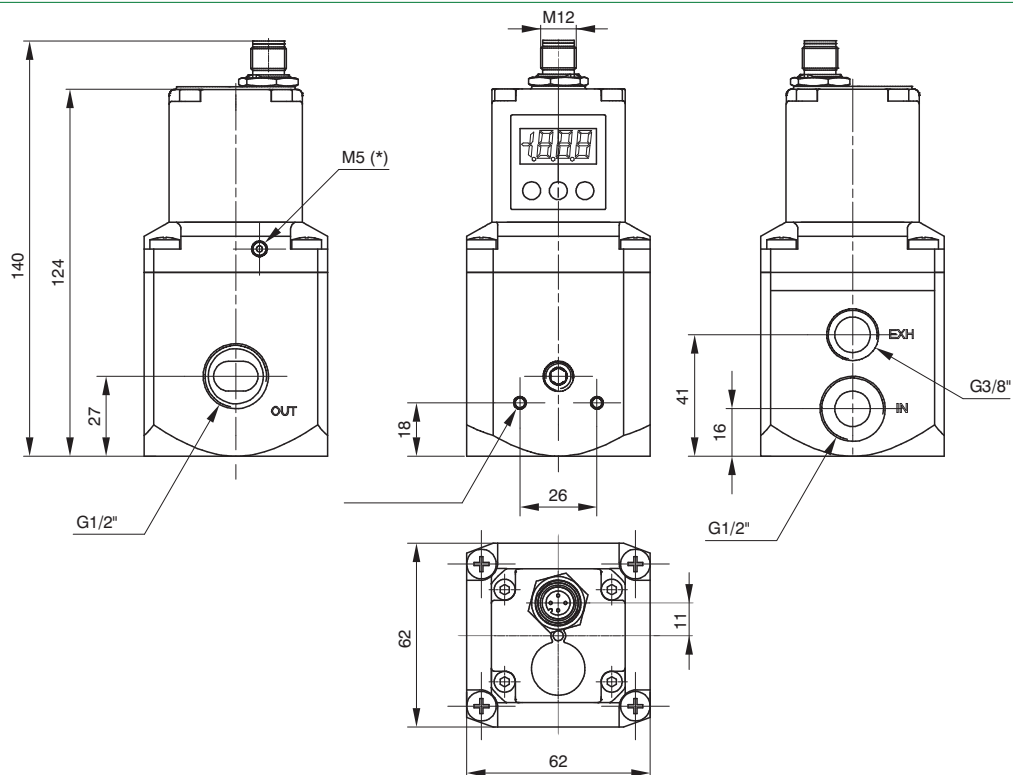

AIR SERVICE UNITS

2

Mounting options ("521 M12 version" - Standard version)

In addition to mounting directly using the M4 tapping on the body, the 170M5 bracket may also be used, as shown below:

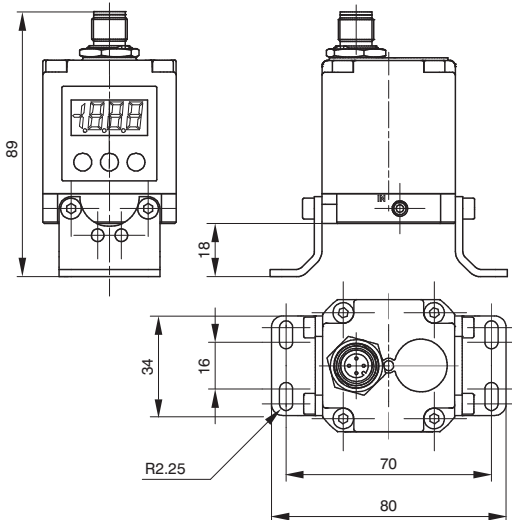

Size 0

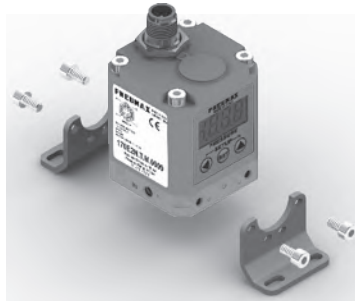

Size 1

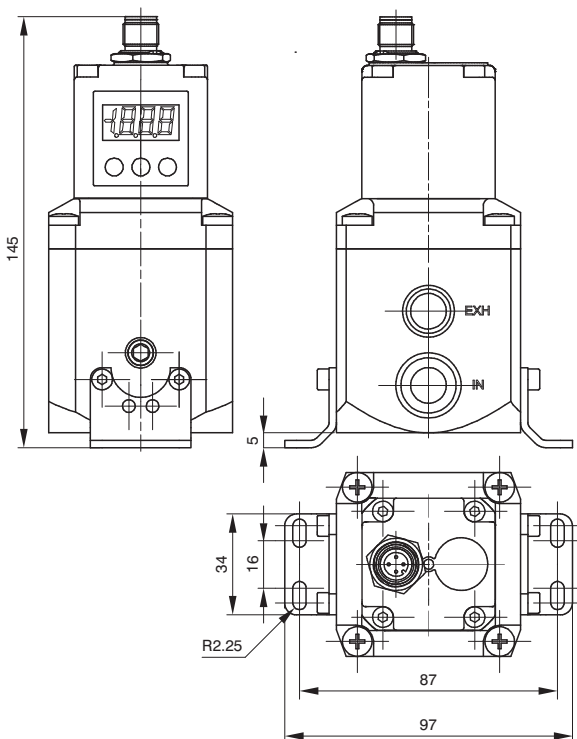
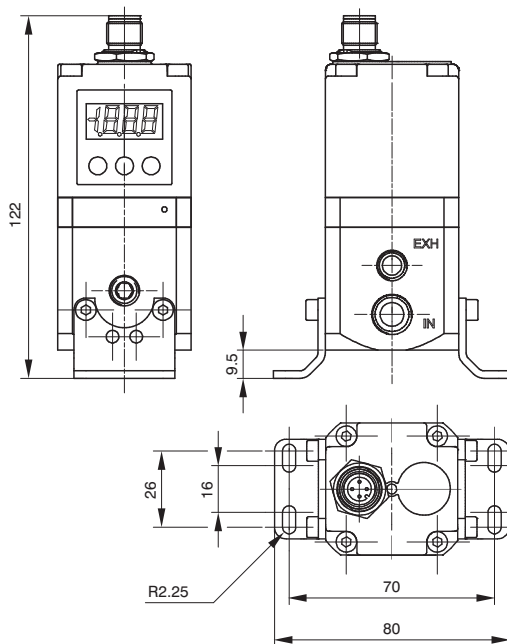

Size 3

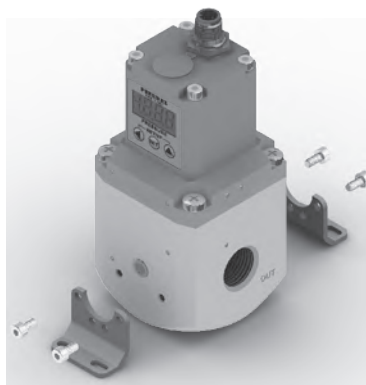

Overall dimensions ("521 IO-Link version")

Size 0

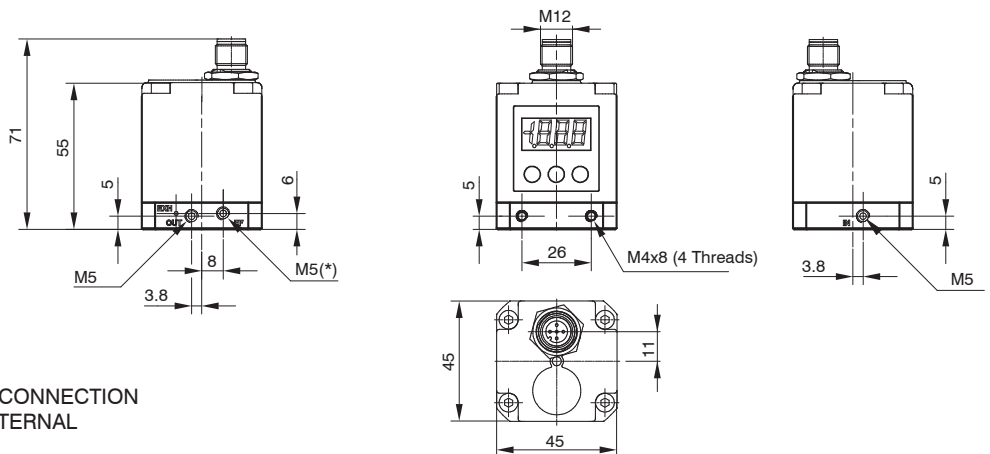

* = EXTERNAL FEEDBACK INPUT CONNECTION
(AVAILABLE ONLY ON THE EXTERNAL
FEEDBACK VERSION)

Size 1

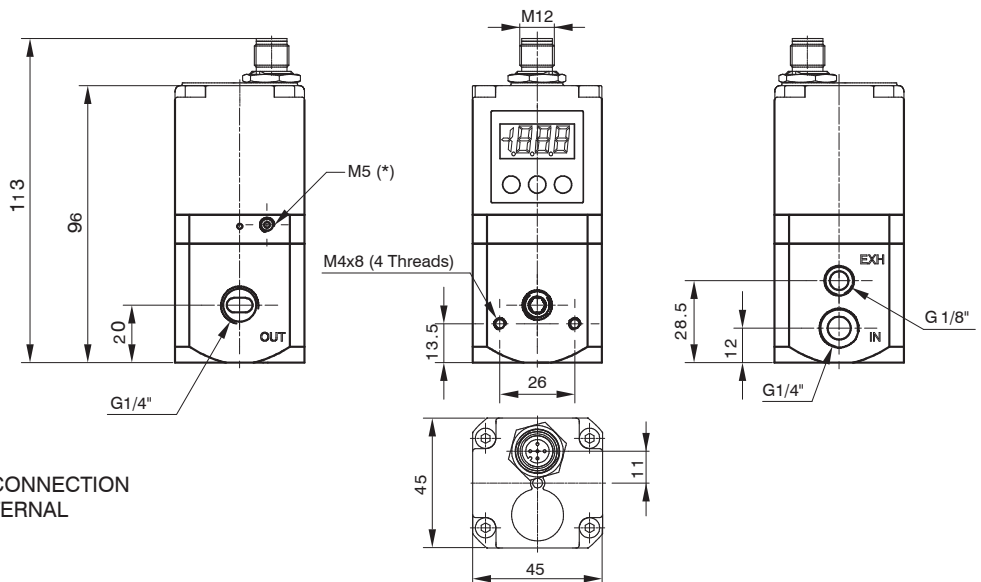

* = EXTERNAL FEEDBACK INPUT CONNECTION
(AVAILABLE ONLY ON THE EXTERNAL
FEEDBACK VERSION)

Size 3

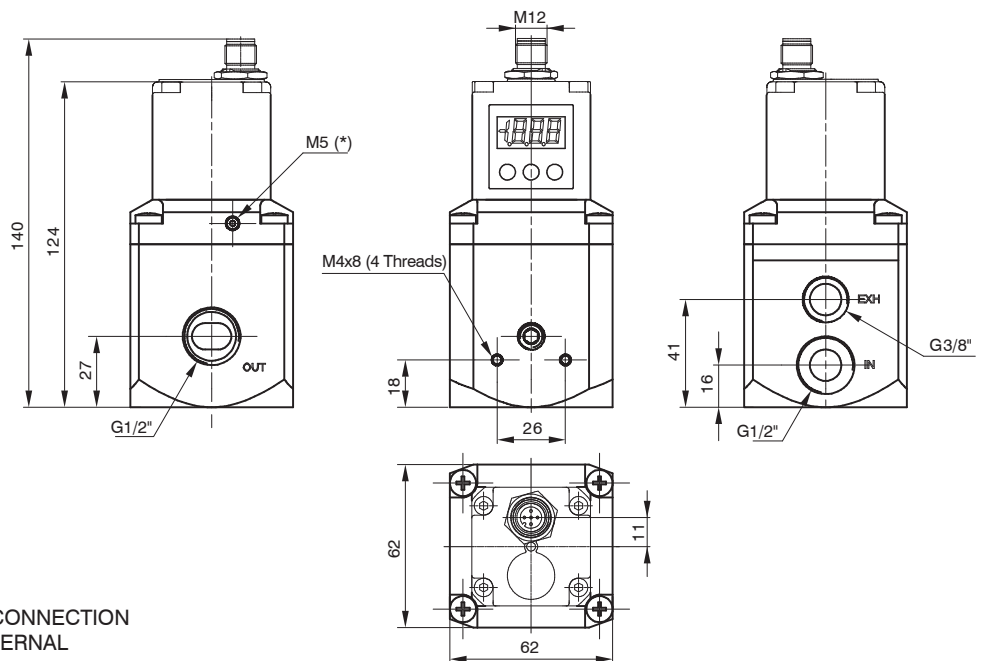

* = EXTERNAL FEEDBACK INPUT CONNECTION
(AVAILABLE ONLY ON THE EXTERNAL
FEEDBACK VERSION)

2 AIR SERVICE UNITS

Mounting options ("521 IO-Link version")

In addition to mounting directly using the M4 tappings on the body, the 170M5 bracket may also be used, as shown below.

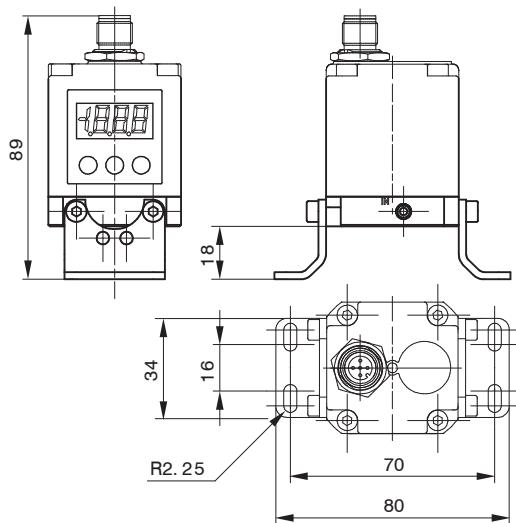

Size 0



Size 1

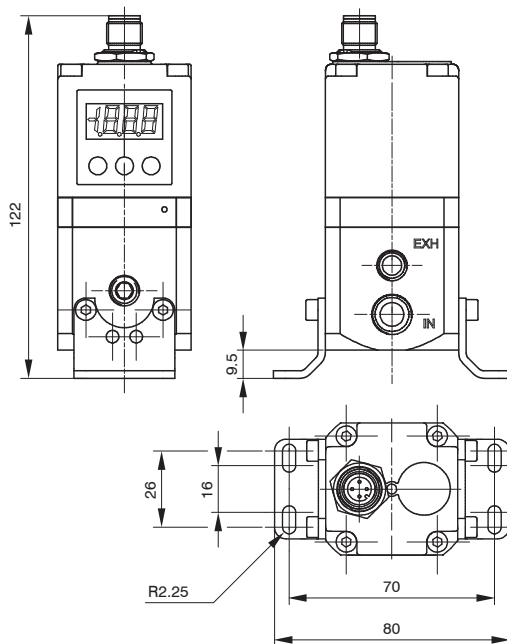

2
AIR SERVICE UNITS

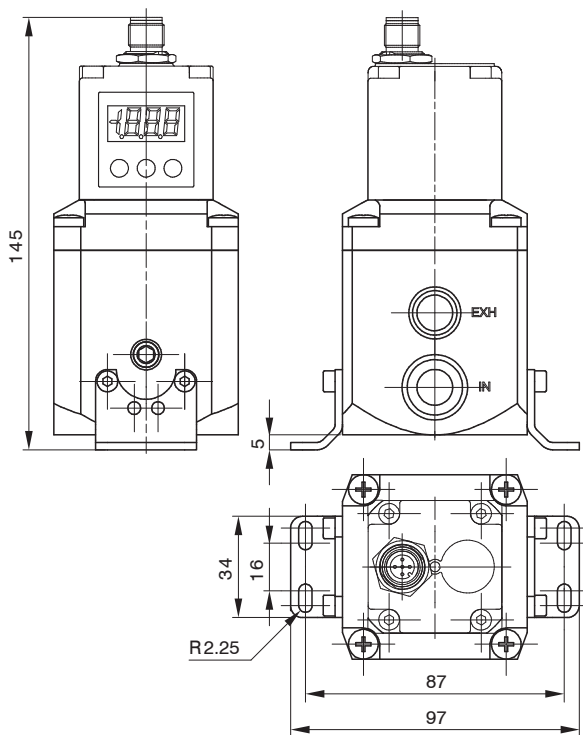

Size 3





Installation/Operation

PNEUMATIC CONNECTION



The compressed air is connected by means of M5 threaded holes (for size 0 regulators), G 1/4" threaded holes (for size 1 regulators) and G 1/2" threaded holes (for size 3 regulators) on the body.
Before making the connections, eliminate any impurities in the connecting pipes to prevent chippings or dust entering the unit. Do not supply the circuit with more than 10 bar pressure and make sure that the compressed air is dried (excessive condensate could cause the appliance to malfunction) and filtered at 5 micron. The supply pressure to the regulator must always be at least 1 bar greater than the desired outlet pressure.
If a silencer is applied to the discharge path the unit response time may change; periodically check that the silencer is not blocked and replace it if necessary.

ELECTRICAL CONNECTION



For the electrical connection a SUB-D 15-pole female or a M12 connector is used (accordingly to the model, to be ordered separately). Wire in accordance with the wiring diagram shown below.

Warning: INCORRECT CONNECTIONS MAY DAMAGE THE DEVICE

NOTES ON OPERATION



If the electric supply is interrupted, the outlet pressure is maintained at the set value. However, maintaining the exact value cannot be ensured as it is impossible to operate the solenoid valves.

In order to discharge the circuit downstream, zero the reference, make sure that the display shows a pressure value equal to zero and then disconnect the electric power supply.

A version of the device is available that exhausts the downstream circuit when the power supply is removed. (Option "A" at the end of the ordering code).

If the compressed-air supply is suspended and the electric power supply is maintained a whirring will be heard that is due to the solenoid valves; an operating parameter can be activated (P18) that triggers the regulator protection whenever the requested pressure is not reached within 4 seconds of the reference signal being sent. In this case the system will intervene to interrupt the control of the solenoid valves. Every twenty seconds, the unit will start the reset procedure until standard operating conditions have been restored.

"521" Standard version with D-SUB connector



TOP VIEW OF THE REGULATOR CONNECTOR

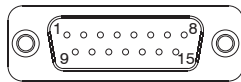

CONNECTOR PINOUT:

- 1 = DIGITAL INPUT 1
- 2 = DIGITAL INPUT 2
- 3 = DIGITAL INPUT 3
- 4 = DIGITAL INPUT 4
- 5 = DIGITAL INPUT 5
- 6 = DIGITAL INPUT 6
- 7 = DIGITAL INPUT 7
- 8 = ANALOG INPUT / DIGITAL INPUT 8
- 9 = SUPPLY (24 VDC)
- 10 = DIGITAL OUTPUT (24 VDC PNP)
- 11 = ANALOG OUTPUT (CURRENT)
- 12 = ANALOG OUTPUT (VOLTAGE)
- 13 = Rx RS-232
- 14 = Tx RS-232
- 15 = GND

"521" M12 BASIC and Standard versions

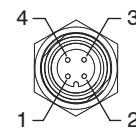

M12 4P MALE

M12 BASIC version

- CONNECTOR PINOUT:**
- 1 = POWER SUPPLY (24 VDC)
 - 2 = NC
 - 3 = GND
 - 4 = ANALOG INPUT

M12 Standard version

- CONNECTOR PINOUT:**
- 1 = POWER SUPPLY (24 VDC)
 - 2 = ANALOG OUTPUT (depending on the model)
 - 3 = GND
 - 4 = ANALOG INPUT

"521" CANopen® version with D-SUB connector



TOP VIEW OF THE REGULATOR CONNECTOR

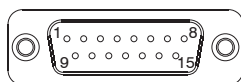

CONNECTOR PINOUT:

- 1 = CAN_SHIELD
- 2 = CAN_V+
- 3 = CAN_GND
- 4 = CAN_H
- 5 = CAN_L
- 6 = NC
- 7 = NC
- 8 = NC
- 9 = SUPPLY (+24 VDC)
- 10 = CAN_SHIELD
- 11 = CAN_V+
- 12 = CAN_GND
- 13 = CAN_H
- 14 = CAN_L
- 15 = GND

"521" CANopen® version with M12 connector

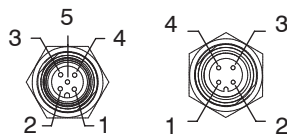
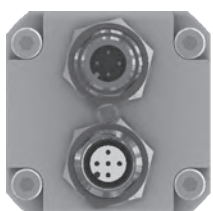

M12 5P FEMALE

M12 4P MALE

"521 IO-Link version"

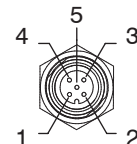

M12 5P MALE

CONNECTOR PINOUT:

- 1 = L+
- 2 = +24 VDC (P24)
- 3 = L-
- 4 = C/Q
- 5 = GND (N24)

2 AIR SERVICE UNITS



ORDERING CODES

"521" standard version with SUB-D 15 poles



17 E2N. . D . .

VARIANT

- = Standard Version
(no additional letter required)
- E** = External pressure feedback
- A** = Exhaust downstream pressure
when power supply is removed
- AE** = A Variant + E Variant

PRESSURE RANGE :

- 0001** = Range 0 - 1 bar
- 0005** = Range 0 - 5 bar
- 0009** = Range 0 - 9 bar

MANAGEMENT :

- C** = Current signal (4-20 mA / 0-20 mA)
- T** = Voltage signal (0-10 V / 0-5 V / 1-5 V)

SIZE :

- 0** = Size 0
- 1** = Size 1
- 3** = Size 3

ORDERING CODES

"521" CANopen® version with SUB-D 15 poles



17 E2N. S . C . .

VARIANT

- = Standard Version
(no additional letter required)
- E** = External pressure feedback
- A** = Exhaust downstream pressure
when power supply is removed
- AE** = A Variant + E Variant

PRESSURE RANGE :

- 0001** = Range 0 - 1 bar
- 0005** = Range 0 - 5 bar
- 0009** = Range 0 - 9 bar

SIZE :

- 0** = Size 0
- 1** = Size 1
- 3** = Size 3

Accessories

Model with SUB-D 15 poles connector	
	5300.F15.00.00 : Straight connector + Casing IP65
	5300.F15.00.03 : Straight connector + Cable 3 meters
	5300.F15.00.05 : Straight connector + Cable 5 meters
	5300.F15.90.00 : 90° connector + Casing IP65
	5300.F15.90.03 : 90° connector + Cable 3 meters
	5300.F15.90.05 : 90° connector + Cable 5 meters

* Whitout cable

Fixing bracket
170M5

2 AIR SERVICE UNITS

ORDERING CODES

"521 M12 version" - CANopen® version



17 E2N. M . C .

SIZE :
0 = Size 0
1 = Size 1
3 = Size 3

VARIANT
= Standard Version
(no additional letter required)
E = External pressure feedback
A = Exhaust downstream pressure
when power supply is removed
AE = A Variant + E Variant

PRESSURE RANGE :
0001 = Range 0 - 1 bar
0005 = Range 0 - 5 bar
0009 = Range 0 - 9 bar

Note:
This model doesn't include
the terminating resistor

Accessories

Model with M12 connector
POWER SUPPLY connector
Female straight connector M12A 4P
5312A.F04.00

Model with M12 connector
NETWORK connector
Male straight connector M12A 5P
5312A.M05.00

Fixing bracket
170M5

ORDERING CODES

"521 M12 BASIC version"



17 E2N. . M .

SIZE :
0 = Size 0
1 = Size 1
3 = Size 3

VARIANT
= Standard Version
(no additional letter required)
E = External pressure feedback
A = Exhaust downstream pressure
when power supply is removed
AE = A Variant + E Variant

PRESSURE RANGE :
0001 = Range 0 - 1 bar
0005 = Range 0 - 5 bar
0009 = Range 0 - 9 bar

MANAGEMENT :
C = Current signal (4-20 mA)
T = Voltage signal (0-10 V)

Note:
This model doesn't include display a keyboard.
Therefore it is not possible to set the parameters.
Unless specifically requested it is provided with
all parameters set with default values.
Personalisations are available.

Accessories

Model with M12 connector
POWER SUPPLY connector
Female straight connector M12A 4P
5312A.F04.00

Fixing bracket
170M5

ORDERING CODES

"521 M12 version" - Standard version



17 E2N.

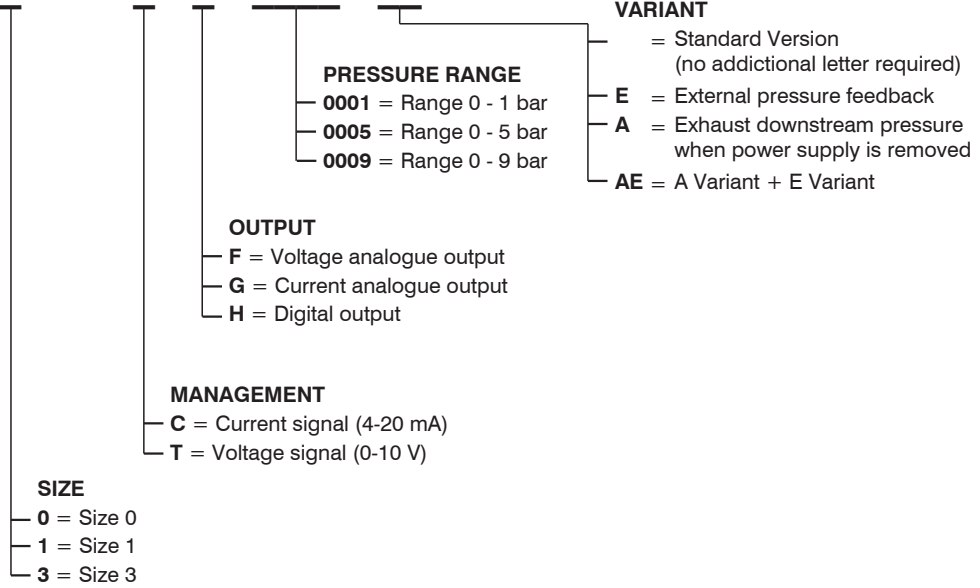

Accessories

Model with M12 connector
POWER SUPPLY connector
Female straight connector M12A 4P
5312A.F04.00

Fixing bracket
170M5

ORDERING CODES

"521 IO-Link version"



17 E2N. I . B.

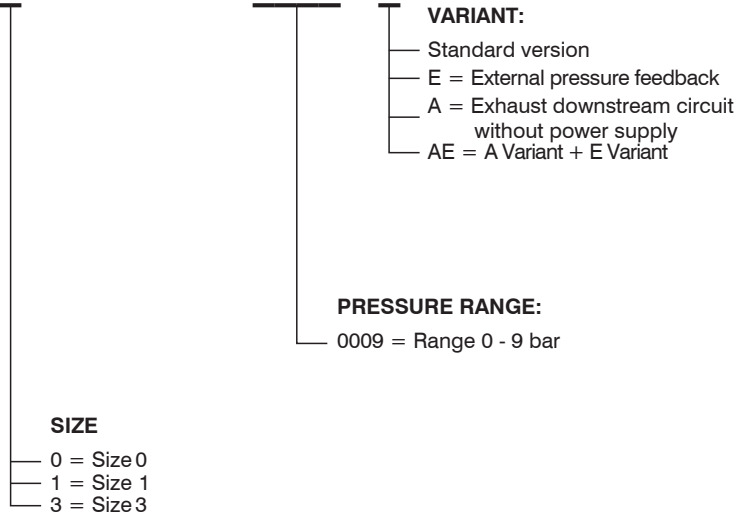

Accessories

Model with M12 connector
POWER SUPPLY connector
Female straight connector M12A 5P
5312A.F05.00

Fixing bracket
170M5



Series 1700 - Miniaturized proportional pressure regulator

General

Modern industrial applications constantly require more sophisticated and better performing pneumatic components. Flexibility and adaptability are key factor when designing a machine. The possibility to change the application parameter during operation such as for example the speed of a cylinder or the force generated by a rotary actuator are beneficial to the designer.

In the past it was necessary to design complicated pneumatic circuits based on pneumatic logic elements which required a lot of space and complicated set up, today, thanks to the electronic proportional regulators such operations are extremely easy to achieve and offer even more flexibility.

Pneumax miniaturized proportional regulators series integrates all the main features of the 521 series with the exclusion of the display and analogue/digital output.

High precision in pressure regulation, fast response speed, assembling options and reduced dimensions are the main advantages.

2

AIR SERVICE UNITS

Features

Pneumatic	Fluid	Air filtered at 5 micron and dehumidified		
	Minimum inlet pressure	Desired outlet pressure + 1 bar		
	Maximum inlet pressure	10 bar		
	Outlet pressure	Ordering code	009	
		Pressure value	0 - 9 bar	
	Nominal flowrate from 1 to 2 (6 bar Δp 1 bar)	7 NI /min		
	Discharge flowrate (at 6 bar with 1 bar overpressure)	7 NI /min		
	Air consumption	M5 / Ø4		
	Operating connection	M5 / Ø4		
	Exhaust connection	M5 / Ø4		
Maximum fitting tightening	3 Nm			
Electric	Supply voltage	24VDC \pm 10% (stabilised with ripple <1%)		
	Standby current consumption	55 mA		
	Current consumption with solenoid valves on	145 mA		
	Reference signal	Voltage*	0 - 10 V	
		Current*	4 - 20 mA	
	Input impedance	Voltage	10 K Ω	
		Current	250 Ω	
Analog outputs voltage	0,2 - 10 V (10 V to 9 bar)			
Connector	M8 4 poles			
Functional	Linearity	< \pm 0,3 % F.S.		
	Hysteresis	<0,3 % F.S.		
	Repeatability	< \pm 0,5 % F.S.		
	Sensitivity	< \pm 0,5 % F.S.		
	Assembly position	Indifferent		
	Protection grade	IP65 (with casing fitted)		
	Ambient temperature	-5° - 50°C / 23° - 122°F		
Constructional	Body	Technopolymer		
	Seals	NBR		
	Cover for electrical part	Technopolymer		
	Weight	60 g		

* Request during ordering process



2
AIR SERVICE UNITS

► Proportional Pressure Regulator c/w M5 In-Line Single Base

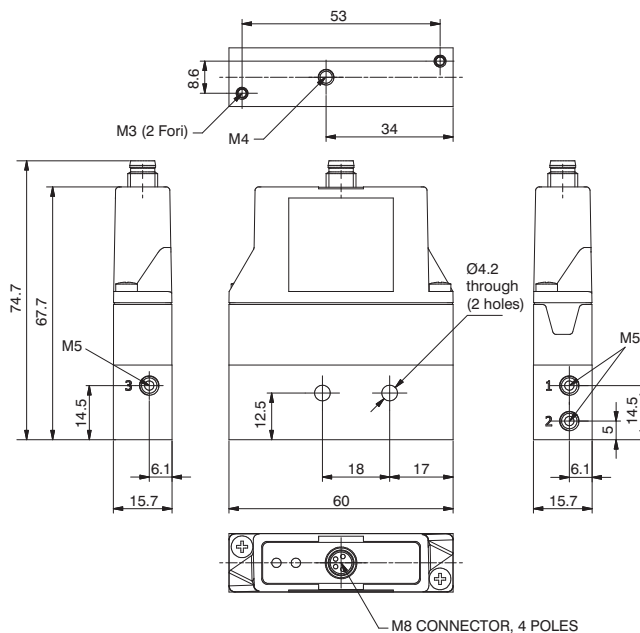

Ordering code	
170EPM.V.M.G.FO	
PROTECTION	
P	0 = Parameter 18 active
	2 = Parameter 18 not active
VERSION	
V	T = Voltage signal
	C = Current signal
PRESSURE RANGE	
G	001= Range 0 - 1 bar
	005= Range 0 - 5 bar
	009= Range 0 - 9 bar

Weight: 110 g

► M5 In-Line Single Base

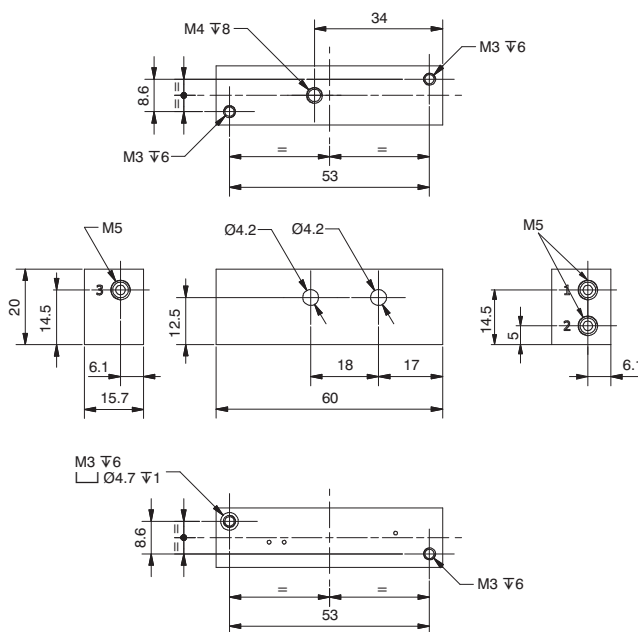

Ordering code	
170M1.FO	

Weight: 50 g

Proportional Pressure Regulator c/w M5 Bottom Entry Base

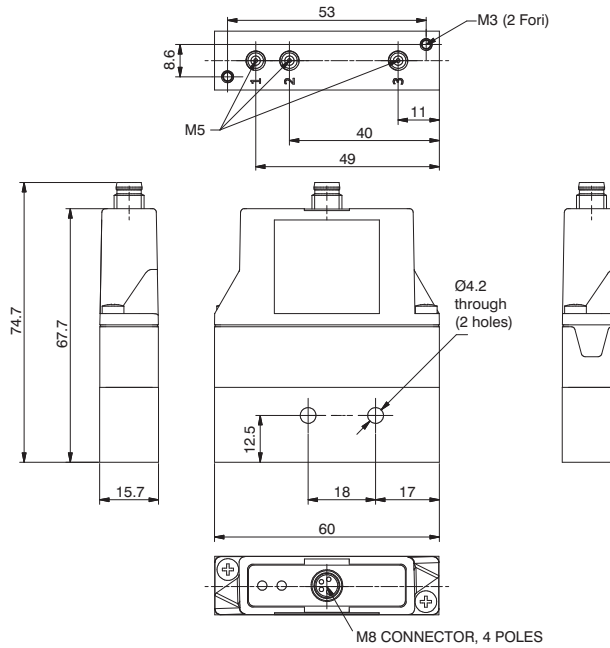

Ordering code	
170E M.V.M.G.FV	
PROTECTION	
P	0 = Parameter 18 active
	2 = Parameter 18 not active
VERSION	
V	T = Voltage signal
	C = Current signal
PRESSURE RANGE	
G	001 = Range 0 - 1 bar
	005 = Range 0 - 5 bar
	009 = Range 0 - 9 bar

Weight: 110 g

M5 Bottom Entry Single Base

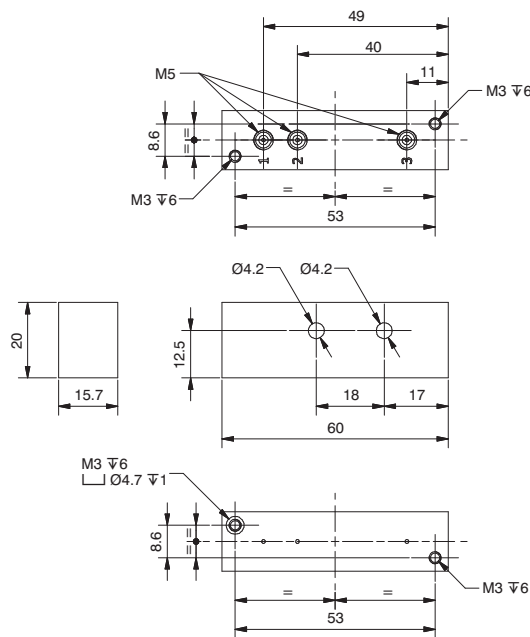

Ordering code	
170M1.FV	

Weight: 50 g

► Proportional Pressure Regulator c/w 4mm In-Line Single base

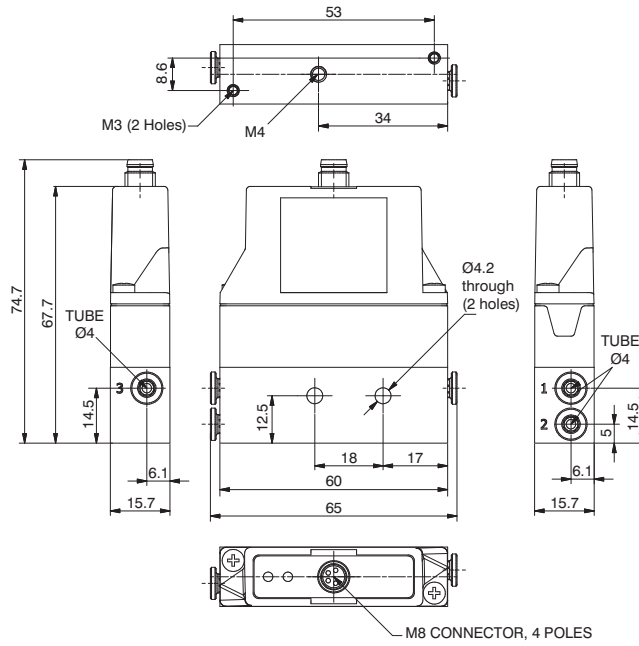

Ordering code	
170E0M.V.M.G.TO	
PROTECTION	
P	0 = Parameter 18 active
	2 = Parameter 18 not active
VERSION	
V	T = Voltage signal
	C = Current signal
PRESSURE RANGE	
G	001 = Range 0 - 1 bar
	005 = Range 0 - 5 bar
	009 = Range 0 - 9 bar

Weight: 110 g

► Single 4mm In-Line Base

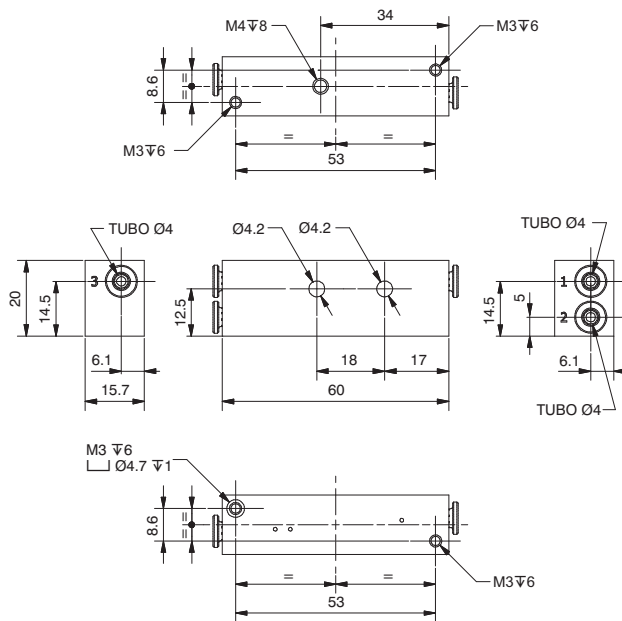

Ordering code	
170M1.TO	

Weight: 50 g

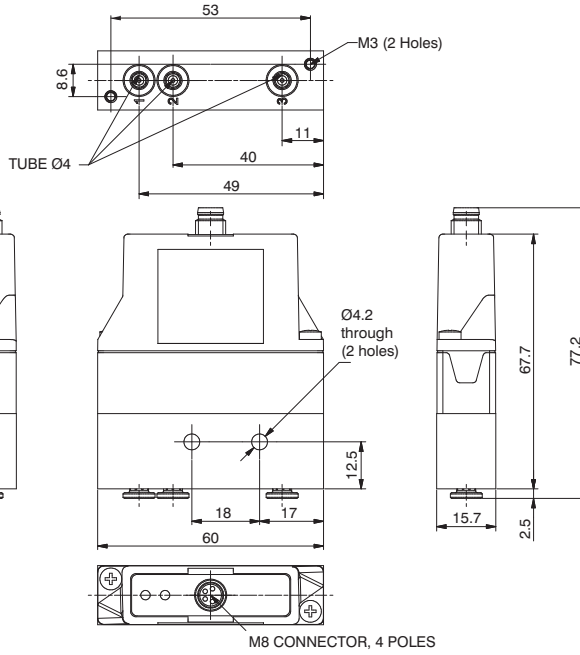

Weight: 110 g

Ordering code	
170EPM.V.M.⊙.TV	
PROTECTION	
P	0 = Parameter 18 active
	2 = Parameter 18 not active
VERSION	
V	T = Voltage signal
	C = Current signal
PRESSURE RANGE	
G	001 = Range 0 - 1 bar
	005 = Range 0 - 5 bar
	009 = Range 0 - 9 bar

2
AIR SERVICE UNITS

Single 4mm Bottom Entry Base

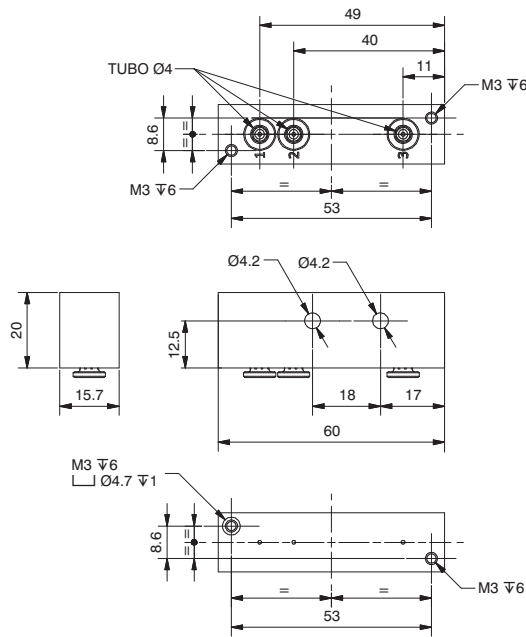

Weight: 50 g

Ordering code	
170M1.TV	

Proportional pressure regulator with external feedback

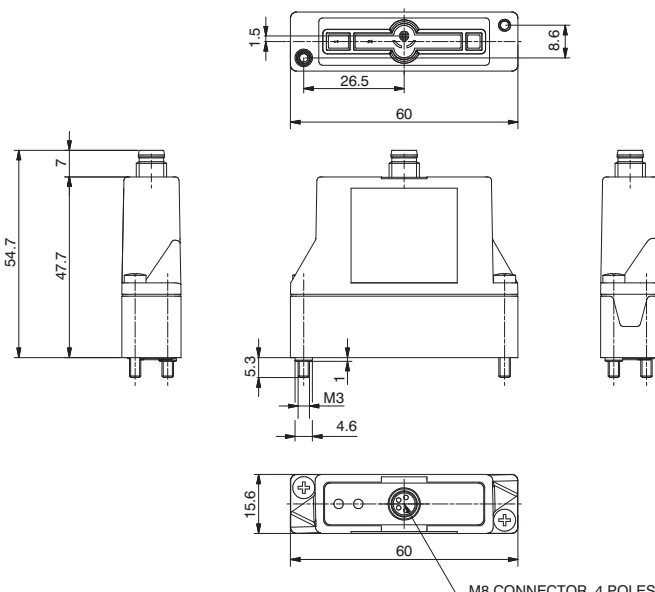

Ordering code	
170E M.C.M. G.E	
PROTECTION	
P	0 = Parameter 18 active
	2 = Parameter 18 not active
VERSION	
V	T = Voltage signal
	C = Current signal
PRESSURE RANGE	
G	001 = Range 0 - 1 bar
	005 = Range 0 - 5 bar
	009 = Range 0 - 9 bar

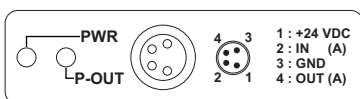
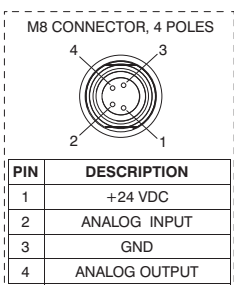

PWR	Green Led: The regulator is properly powered
P-OUT	Green Led: lights up when the outlet pressure is higher than the desired pressure minus 0.2 bar and less than the desired pressure more 0.2 bar

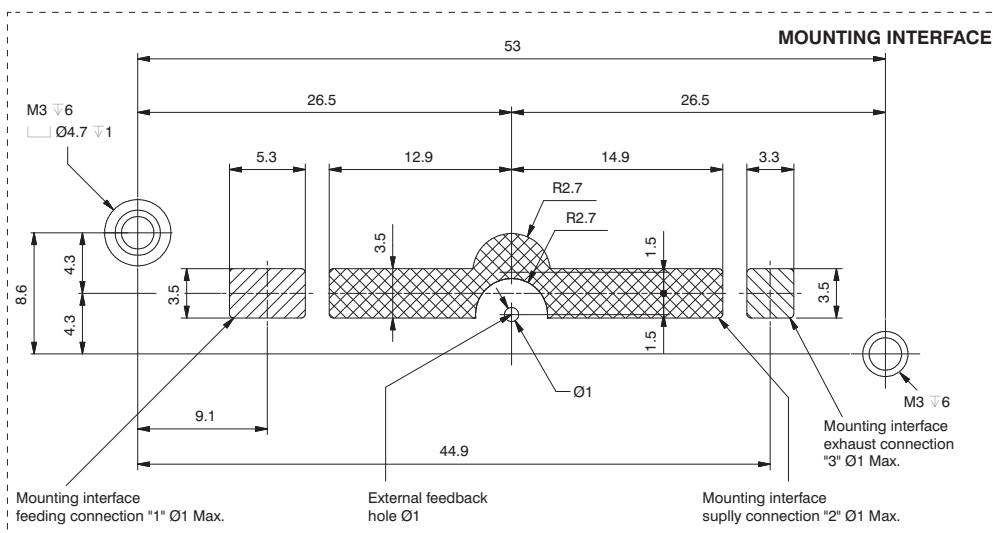

► Proportional Pressure Regulator c/w M5 In-Line Single Base with External Feedback

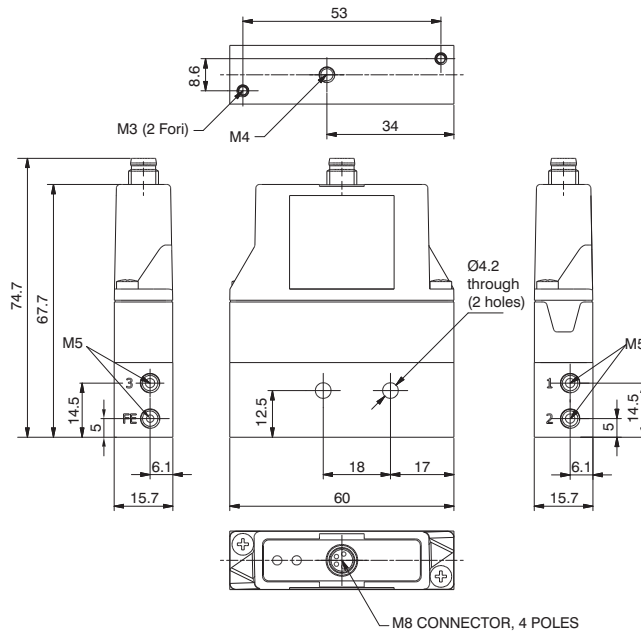

Ordering code	
170EPM.V.M.G.EFO	
PROTECTION	
P	0 = Parameter 18 active
	2 = Parameter 18 not active
VERSION	
V	T = Voltage signal
	C = Current signal
PRESSURE RANGE	
G	001 = Range 0 - 1 bar
	005 = Range 0 - 5 bar
	009 = Range 0 - 9 bar

Weight: 110 g

► Single M5 In-Line Base with External Feedback

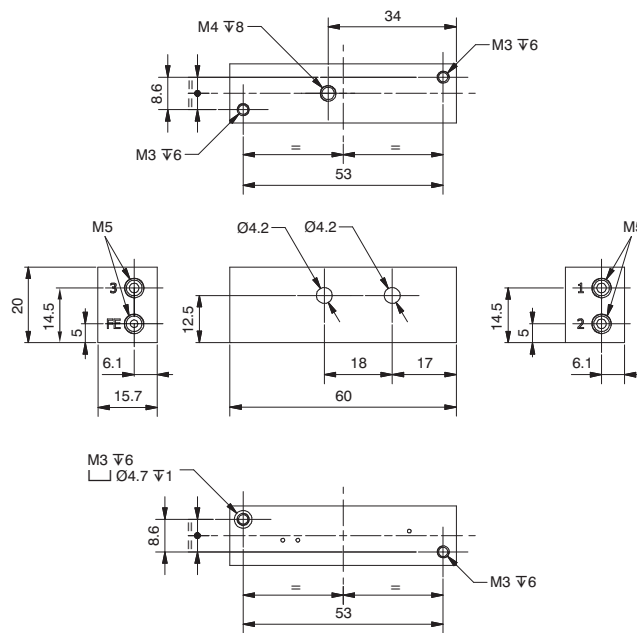

Ordering code	
170M1.EFO	

Weight: 50 g

2

AIR SERVICE UNITS



Proportional Pressure Regulator c/w M5 Bottom Entry Base with External Feedback

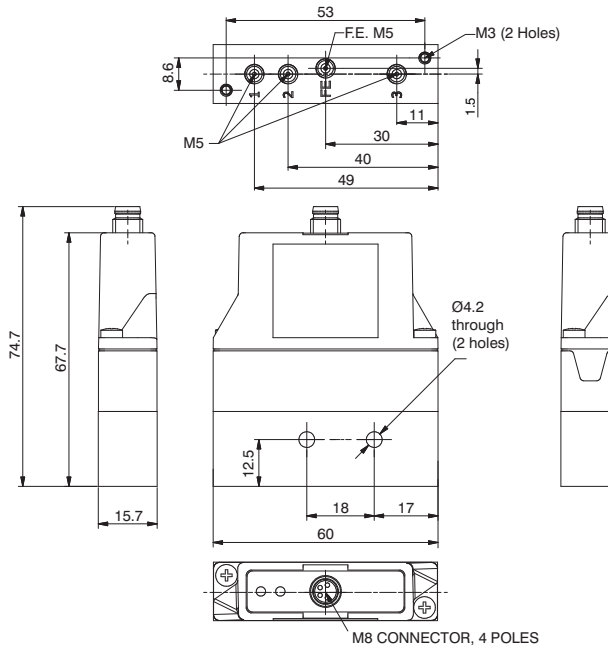

Ordering code	
170EPM.V.M.G.EFV	
PROTECTION	
P	0 = Parameter 18 active
	2 = Parameter 18 not active
VERSION	
V	T = Voltage signal
	C = Current signal
PRESSURE RANGE	
G	001 = Range 0 - 1 bar
	005 = Range 0 - 5 bar
	009 = Range 0 - 9 bar

Weight: 110 g

Single M5 Bottom Entry Base with External Feedback

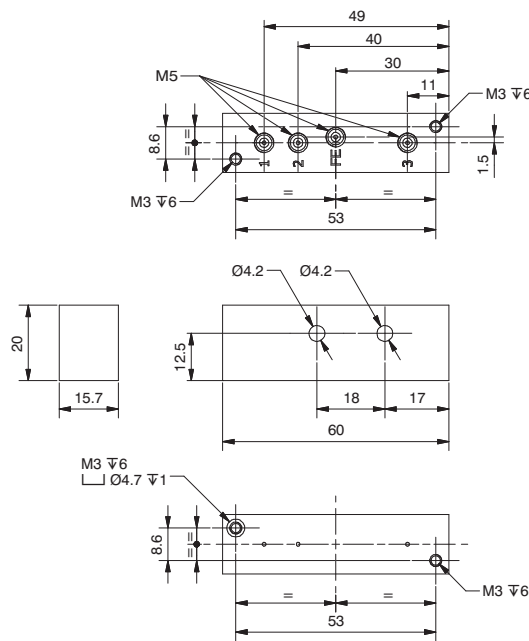

Ordering code	
170M1.EFV	

Weight: 50 g

► Proportional Pressure Regulator c/w 4mm In-Line Single Base with External Feedback

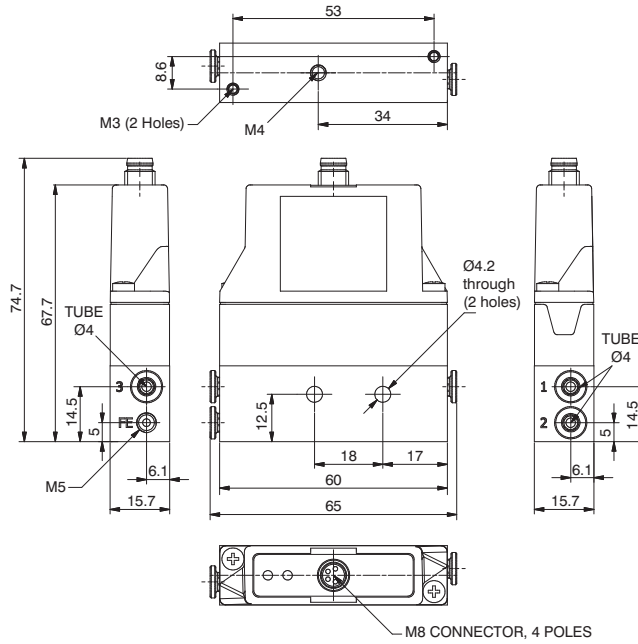

Ordering code	
170EPM.V.M.⊙.ETO	
PROTECTION	
P	0 = Parameter 18 active
	2 = Parameter 18 not active
VERSION	
V	T = Voltage signal
	C = Current signal
PRESSURE RANGE	
⊙	001 = Range 0 - 1 bar
	005 = Range 0 - 5 bar
	009 = Range 0 - 9 bar

Weight: 110 g

► Single 4mm In-Line Base with External Feedback

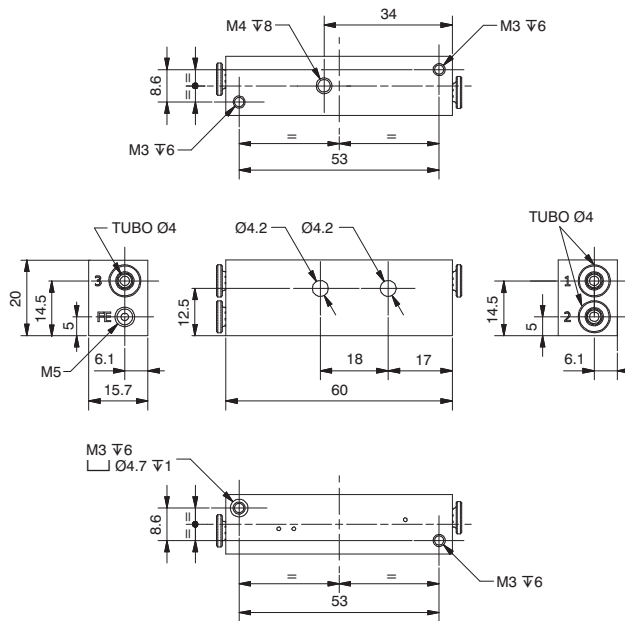

Ordering code	
170M1.ETO	

Weight: 50 g



Proportional Pressure Regulator c/w 4mm Bottom Entry Single Base with External Feedback

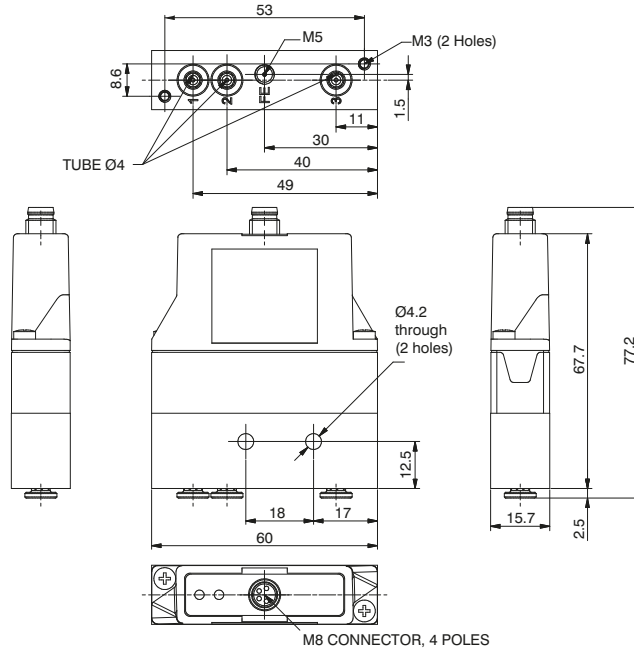

Weight: 110 g

Ordering code	
170EPM.V.M.G.ETV	
PROTECTION	
P	0 = Parameter 18 active
	2 = Parameter 18 not active
VERSION	
V	T = Voltage signal
	C = Current signal
PRESSURE RANGE	
G	001 = Range 0 - 1 bar
	005 = Range 0 - 5 bar
	009 = Range 0 - 9 bar

Single 4mm Bottom Entry Base with External Feedback

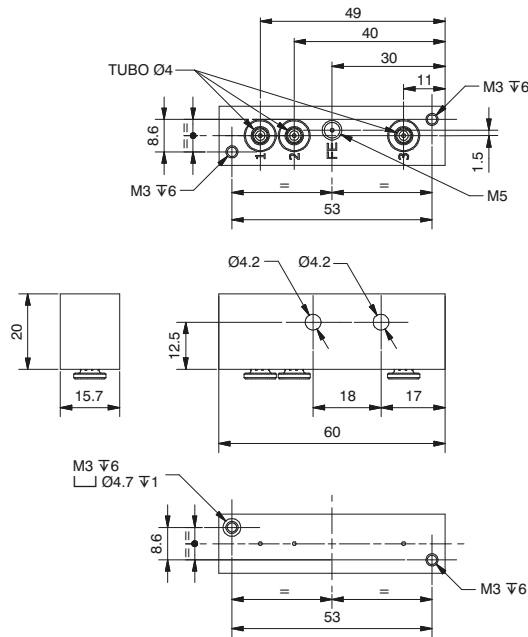

Weight: 50 g

Ordering code	
170M1.ETV	

Coding For Proportional Pressure Regulator Modular Manifold

It is possible to assemble a manifold of Miniature Proportional Regulators to a maximum of 12 Regulators.
For the coding of the Manifold, refer to the configuration Table below.

The Regulators are fed by a single supply pressure via the G1/8" connection. In the Manifold, the Pressure Regulators operate independently, the output pressure is supplied via the M5 or 4mm output connection depending on the model requested. The electrical signal is controlled via the M8 connector.

There are also configured single bases up to a maximum of 12 positions with power supplies and independent consumptions (See following pages).

G	1	7	0	-	-	-	M	-	-	-	P	-
Group	Series	Size	Parameter 18	N. Places	Control Type	Electrical connection	Pressure range	Connection	Version	Options		
			0=Eco P18 On	A=02	T=Voltage		001=0 - 1 bar	T=Tube Ø4		= Standard *		
			2=Eco P18 Off	B=03	C=Current		005=0 - 5 bar	F=M5 Thread		E= External feedback		
				C=04			009=0 - 9 bar			* no additional letter required		
				D=05								
				E=06								
				F=07								
				G=08								
				H=09								
				I=10								
				L=11								
				M=12								

Example	
Code	G1700ITM009FP
Description	10 Position Miniature Proportional Pressure Regulator, Voltage controlled with M5 Outputs

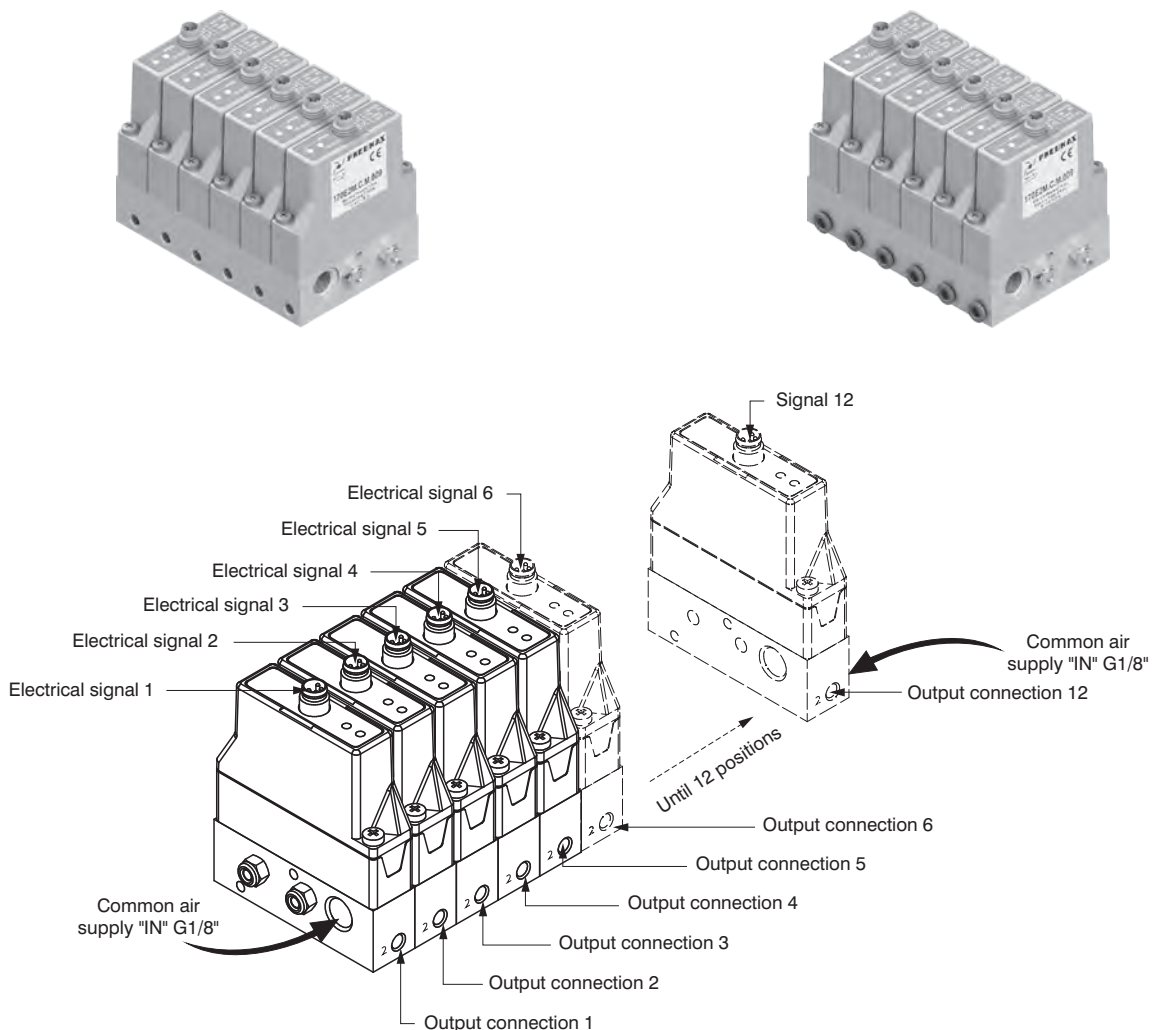

Multiple M5 In-Line Base

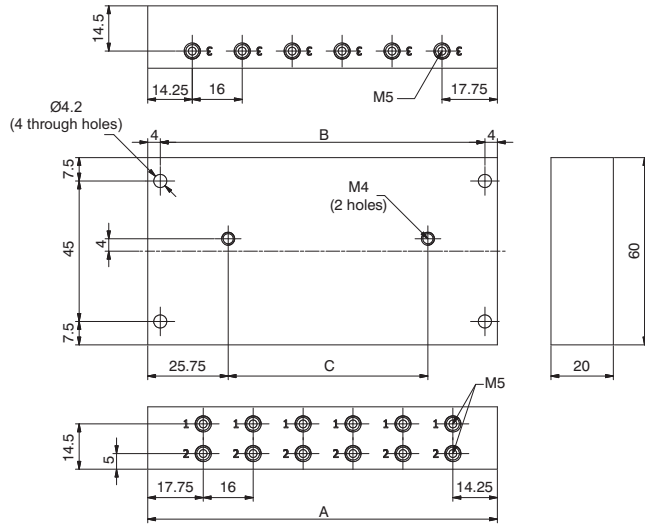
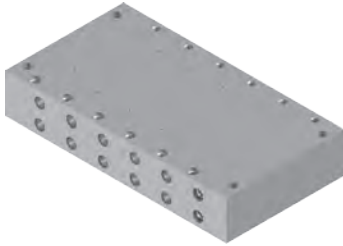

DIMEN.	N° PLACES									
	2 PLA.	3 PLA.	4 PLA.	5 PLA.	6 PLA.	7 PLA.	8 PLA.	9 PLA.	10 PLA.	
A	48	64	80	96	112	128	144	160	176	
B	40	56	72	88	104	120	136	152	168	
C	0	16	32	48	64	80	96	112	128	

Ordering code	
170M\emptyset.FO	
N. PLACES	
2=2 places (weight gr.100)	
3=3 places (weight gr.150)	
4=4 places (weight gr.200)	
5=5 places (weight gr.250)	
6=6 places (weight gr.300)	
7=7 places (weight gr.350)	
8=8 places (weight gr.400)	
9=9 places (weight gr.450)	
10=10 places (weight gr. 500)	

Multiple M5 Bottom Entry Base

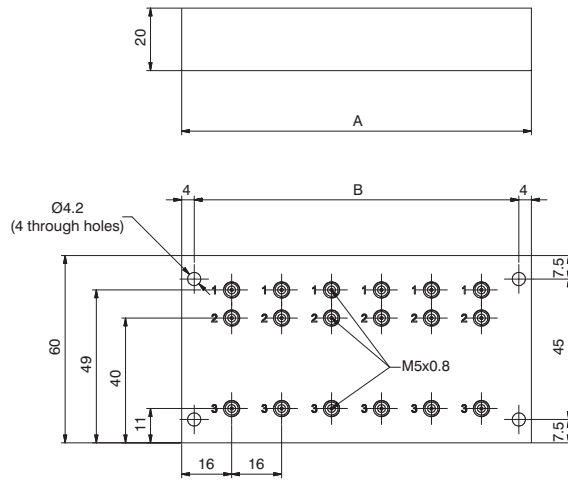

DIMEN.	N° PLACES									
	2 PLA.	3 PLA.	4 PLA.	5 PLA.	6 PLA.	7 PLA.	8 PLA.	9 PLA.	10 PLA.	
A	48	64	80	96	112	128	144	160	176	
B	40	56	72	88	104	120	136	152	168	

Ordering code	
170M\emptyset.FV	
N. PLACES	
2=2 places (weight gr.100)	
3=3 places (weight gr.150)	
4=4 places (weight gr.200)	
5=5 places (weight gr.250)	
6=6 places (weight gr.300)	
7=7 places (weight gr.350)	
8=8 places (weight gr.400)	
9=9 places (weight gr.450)	
10=10 places (weight gr. 500)	

Multiple M5 In-Line Base with External Feedback

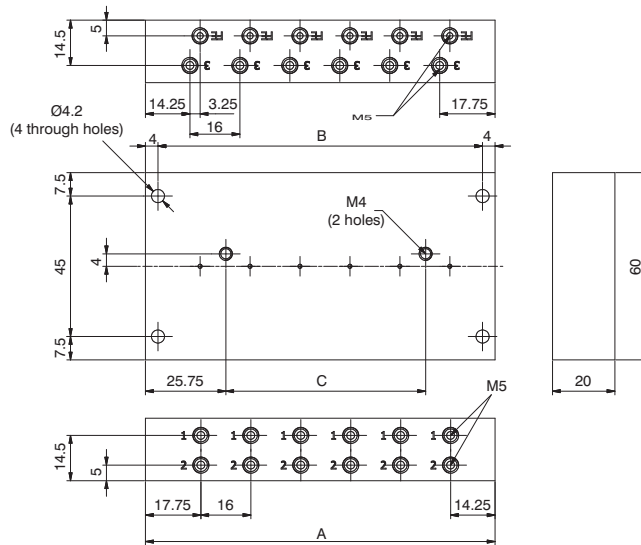
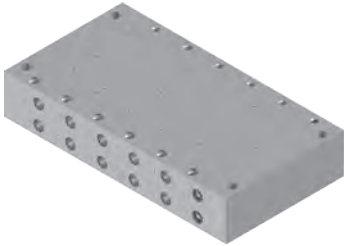

Ordering code	
170M\varnothing.EFO	
N. PLACES	
2=2 places (weight gr.100)	
3=3 places (weight gr.150)	
4=4 places (weight gr.200)	
5=5 places (weight gr.250)	
6=6 places (weight gr.300)	
7=7 places (weight gr.350)	
8=8 places (weight gr.400)	
9=9 places (weight gr.450)	
10=10 places (weight gr. 500)	

DIMEN.	N° PLACES									
	2 PLA.	3 PLA.	4 PLA.	5 PLA.	6 PLA.	7 PLA.	8 PLA.	9 PLA.	10 PLA.	
A	48	64	80	96	112	128	144	160	176	
B	40	56	72	88	104	120	136	152	168	
C	0	16	32	48	64	80	96	112	128	

Multiple M5 Bottom Entry Base with External Feedback

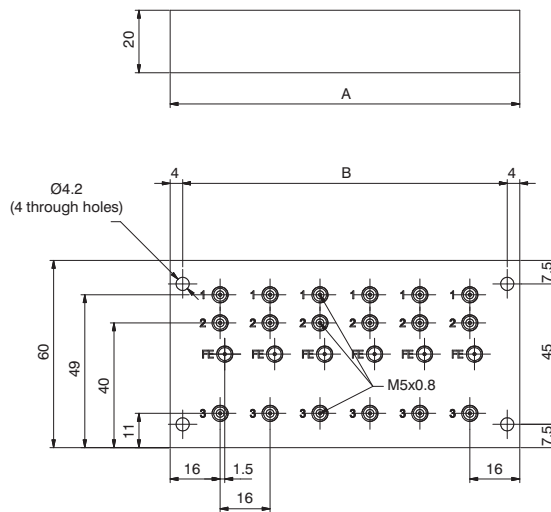
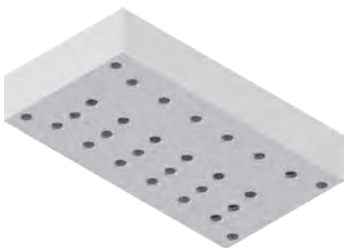

Ordering code	
170M\varnothing.EFV	
N. PLACES	
2=2 places (weight gr.100)	
3=3 places (weight gr.150)	
4=4 places (weight gr.200)	
5=5 places (weight gr.250)	
6=6 places (weight gr.300)	
7=7 places (weight gr.350)	
8=8 places (weight gr.400)	
9=9 places (weight gr.450)	
10=10 places (weight gr. 500)	

DIMEN.	N° PLACES									
	2 PLA.	3 PLA.	4 PLA.	5 PLA.	6 PLA.	7 PLA.	8 PLA.	9 PLA.	10 PLA.	
A	48	64	80	96	112	128	144	160	176	
B	40	56	72	88	104	120	136	152	168	

Clip

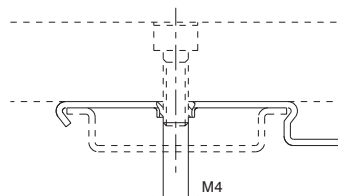

Ordering code	
800.00	

Weight g 5