

Document number  
S071

Revision  
C

Date  
2011-10-17

Document type  
Manual

# SERVICE MANUAL

## Remote Control System RC400 G2B/G3B



# Contents

<b>1</b>	<b>General.....</b>	<b>3</b>
1.1	Synopsis	3
1.2	Distribution	3
1.3	Terminology	4
1.4	Applicable products	4
1.5	Product identification	5
<b>2</b>	<b>Preface.....</b>	<b>6</b>
2.1	General information	6
<b>3</b>	<b>General system description.....</b>	<b>7</b>
3.1	General description	7
3.2	Schematic overview of Scanreco RC-400 G2B	8
3.3	Schematic overview of Scanreco RC400 G3B	9
<b>4</b>	<b>Getting started.....</b>	<b>10</b>
4.1	Portable Control Unit definition	10
4.2	Central Unit G2B definition	11
4.3	Central Unit G3B definition	12
4.4	Cable or radio communication	13
4.5	Cable connection schematics	13
<b>5</b>	<b>Inputs &amp; Outputs.....</b>	<b>14</b>
5.1	Analogue functions	14
5.2	Portable Control Unit MAXI digital inputs	16
5.3	Portable Control Unit MINI digital inputs	17
5.4	Digital functions	18
5.5	Terminal schematics for current controlled Central Unit G2B	19
5.6	Terminal schematics for voltage controlled Central Unit G2B	20
5.7	Terminal schematics for Central Unit G2B CAN interface	21
5.8	Connection schematics for Central Unit G3B	22
<b>6</b>	<b>Operational indications.....</b>	<b>23</b>
6.1	Central Unit status and operational indications	23
6.2	Central Unit LED-display	24
6.3	Portable Control Unit status indications	25
<b>7</b>	<b>Error code indications.....</b>	<b>26</b>
7.1	General description	26
7.2	Central Unit error codes	26
7.3	Portable Control Unit error codes	29
<b>8</b>	<b>Radio.....</b>	<b>30</b>
8.1	General description	30
8.2	Determining radio quality	30
8.3	Radio channel / Frequency	30
8.4	Range	30
<b>9</b>	<b>Diagnostics mode.....</b>	<b>31</b>
9.1	General description	31
9.2	Activating diagnostics mode	31
9.3	Table / Diagnostics data	32
<b>10</b>	<b>Online Programming mode.....</b>	<b>35</b>
10.1	General description	35
10.2	Activating online programming mode	36
10.3	Table / Programming options	37
<b>11</b>	<b>Portable Control Unit self test mode.....</b>	<b>40</b>
11.1	General description	40
11.2	Activating PCU Test Mode	40
<b>12</b>	<b>ID-code programming.....</b>	<b>41</b>
12.1	General description	41
12.2	Procedure	41
<b>13</b>	<b>G2B Standard cable kits.....</b>	<b>42</b>
13.1	General description	42
13.2	Standard supply cable kits	43
13.3	Standard valve cable kits for Sauer-Danfoss PVG-32	44
13.4	Standard valve cable kits for HAWE	45
13.5	Standard valve cable kits for PWM solenoids	46

## Document information

Attribute	Information
Document type	Manual
Title	Remote Control System RC400 G2B / G3B
Subtitle	Service Manual
Document number	S071
Filename	S071
Revision	C
Revision date	2011-10-17

## Revision history

Revision	Date	Name	Note
A	2010-10-29	Scanreco AB	First release
B	2011-08-14	Scanreco AB	G3B Central Unit added Major changes in document
C	2011-10-17	Scanreco AB	G2B Standard Cable kit chapter added Minor changes in document

# 1 General

## 1.1 Synopsis

Scanreco Remote Control System RC400 G2B/G3B Service Manual

This service manual is intended as a complement to the Remote Control System RC400 G2B Instruction manual and covers more in-depth information surrounding service and fault findings on the systems.

## 1.2 Distribution

Name	Rule
Internal	Only within own organization

### 1.3 Terminology

Abbreviation	Description
n/a	Not applicable
PWM	Pulse Width Modulation
PCU	Portable Control Unit
CU	Central Unit
LED	Light Emitting Diode
ST	Status LED
DV	Dump Valve

### 1.4 Applicable products

This document is applicable on the below declared products and program versions.

Item no:	Description	Program version
3010	G2B Central Unit PWM EU	4.10
3011	G2B Central Unit PWM NAFTA	4.10
2010	G2B Central Unit Danfoss EU	2.14
2011	G2B Central Unit Danfoss NAFTA	2.14
1602	G3B Central Unit Type 1 EU	1.00
1603	G3B Central Unit Type 1 NAFTA	1.00
1604	G3B Central Unit Type 2 EU	1.00
1605	G3B Central Unit Type 2 NAFTA	1.00
n/a*	G2B Portable Control Unit Maxi Linear	1.07
n/a*	G2B Portable Control Unit Maxi Joystick	1.07
n/a*	G2B Portable Control Unit Mini Linear	1.07
n/a*	G2B Portable Control Unit Mini Joystick	1.07

\*Due to the variety of configurations available for the Portable Control Units, item numbers are not declared; only the available Portable Control Unit platform types are declared, for more detailed information refer to customer part list where available.

## 1.5 Product identification

All SCANRECO Products are labeled with product part number and serial number for verification. Below illustrations shows where these numbers can be located.

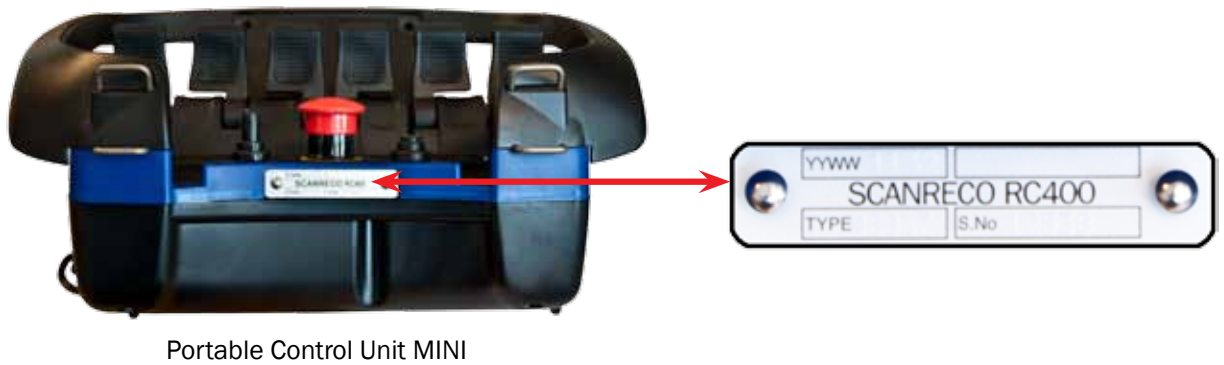
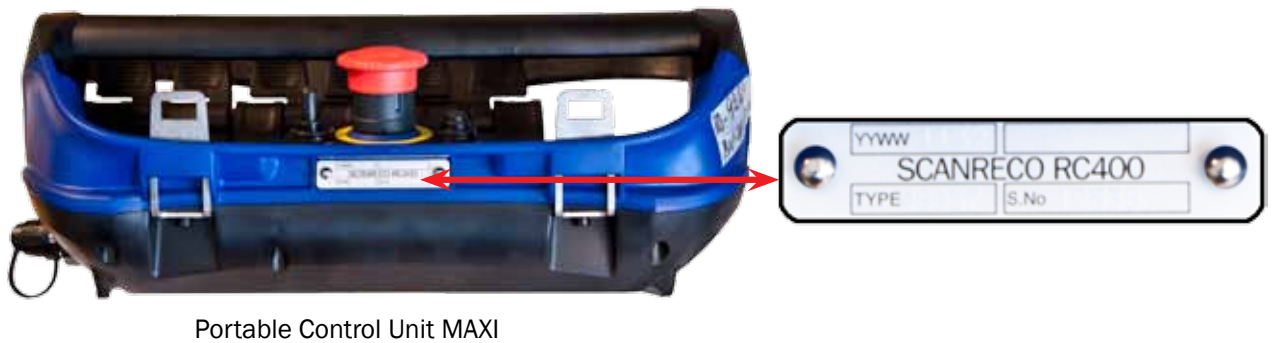
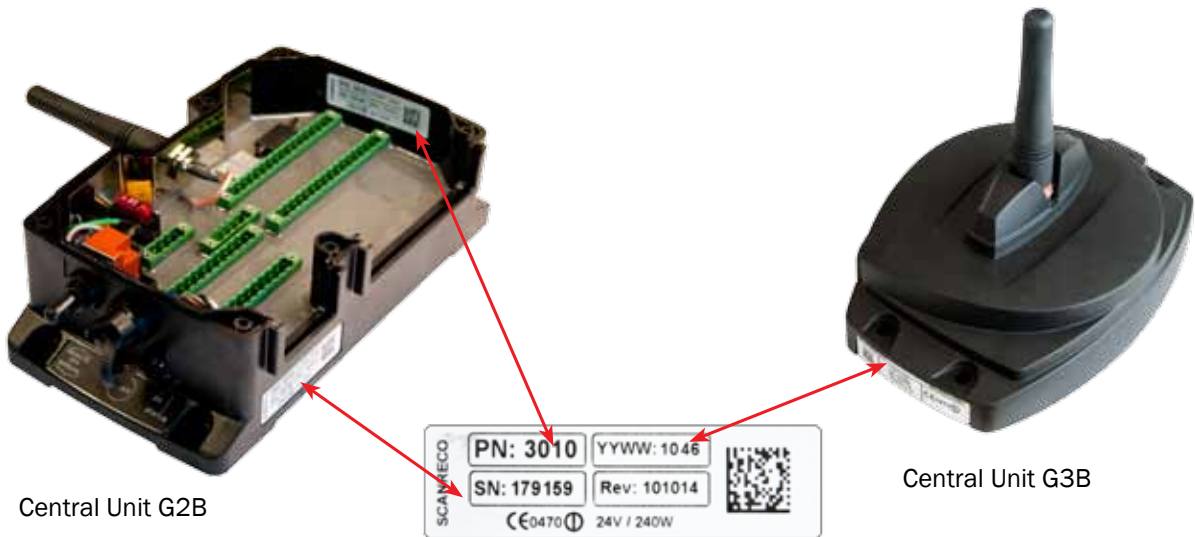

Always check and verify product item- and serial no. before any type of service is commissioned, refer to customer parts list and system-/product technical specifications in order to determine system-/product configuration.

## 2 Preface

---

### 2.1 General information

This manual is intended as a complement to the crane / machine instruction book and covers the Scanreco RC 400 G2B/G3B Remote Control System.

The Scanreco RC 400 G2B/G3B offers the driver an extremely advanced remote control system with speed, precision, control and maximum safety.

In order to ensure your safety and the safety of your crane / machine you should study and learn these instructions. This will enable you to quickly familiarise yourself with your new remote control system and how to utilise it.

- Remotely controlled cranes may only be operated by qualified personnel. The driver must be aware of the contents of chapter 4 “Safety regulations and Operating instructions” available in the Instruction Manual before operation is started. Serious accidents may occur if these instructions are not followed.
- To protect the portable control unit from damage and for safety reasons, the control unit must be kept in a locked cabin
- Follow the instructions given in the crane handbook regarding moving the crane from its parking position, the best arm positioning while loads are being handled and parking of the crane.
- Due to the unlimited variety of cranes, machines, objects, vehicles and equipment on which the remote control system are used, and the numerous standards which are frequently the subject of varying interpretation, it is impossible for the personnel at Scanreco to provide expert advice regarding the suitability of a given remote control for a specific application. It is the responsibility of the purchaser to determine the suitability of any Scanreco remote control product for an intended application and to insure that it is installed and guarded in accordance with all country, federal, state, local, and private safety and health regulation, codes, standards and Scanreco recommendation (this manual). If the Scanreco RC 400 G2B/G3B will be used in a safety critical application, the customer / driver must undertake appropriate testing and evaluation to prevent injury to the ultimate user. Scanreco does not take responsibility for any damage or injury.
- Unauthorized tampering with a Scanreco remote control system automatically invalidates guarantee.

## 3 General system description

---

### 3.1 General description of Scanreco RC-400 G2B/G3B

The Scanreco RC 400 G2B/G3B remote control system has been especially developed for hydraulically driven mobile cranes and machinery. The system is a digital remote control system based on an extremely advanced microprocessor technology. Years of exhaustive and demanding testing have shown that the remote control system can cope with the roughest of environments.

The system is protected against electromagnetic and radio frequency radiation and can be installed onto most hydraulic valve types (voltage, current pulse width, or protocol steered) found on the market.

In its basic form the remote control system is comprised of a portable control unit with manoeuvre levers for proportional control and switches for ON/OFF functions, a central unit with connection cable for driving proportional electro-hydraulic slide controllers.

Digitally coded control information (lever deflection and switch position) is sent from the control unit via electric cable or via radio to the central unit. The control unit and central unit translate the magnitude and direction of the manoeuvre lever deflections and switch positions to corresponding valve function, speed and direction and thus crane movement.

### 3.2 Schematic overview of Scanreco RC-400 G2B

Below illustrations shows a typical system consistency for the G2B system



No	Description	Qty
1	Portable Control unit (PCU)	1
2	Central unit G2B (CU)	1
3	Battery Charger (10 - 30 VDC)	1
4	Battery cassette (NiMH 7.2 VDC)	2
5	Manoeuvre cable (10 meters)	1
6	Emergency stop box (Optional)	1
7	Cable kit supply cables + digital outputs	1
8	Cable kit valves cables (analogue outputs)	1



### 3.3 Schematic overview of Scanreco RC-400 G3B

Below illustrations shows a typical system consistency for the G3B system



No	Description	Qty
1	Portable Control unit (PCU)	1
2	Central unit G3B (CU)	1
3	Battery Charger (10 - 30 VDC)	1
4	Battery cassette (NiMH 7.2 VDC)	2
5	Manoeuvre cable (10 meters)	1

## 4 Getting started

### 4.1 Portable Control Unit definition

The illustrations below aims to delare all entities mentioned in this document.



### Activating the Portable Control Unit

#### Insert battery or connect cable connector!

1. Twist up the Stop-button
2. Press the On-button once  
- LED-Power will be illuminated RED



## 4.2 Central Unit G2B definition

The illustrations below aims to declare all entities mentioned in this document.



### Activating the Central Unit

The Central Unit can be activated in two modes via the R/M switch; REMOTE or MANUAL mode. In REMOTE mode the Central Unit is controlled by the PCU, in MANUAL mode the system supplies only the DV-output intended for Dump valve supply; the complete system is by-passed allowing manual operation of distributor bench (where available).

#### REMOTE MODE:

Operation via PCU  
LED STATUS will be illuminated red at first then green when in contact with PCU.

#### MANUAL MODE:

System by-pass / Manual operation

LED DV will be illuminated red.

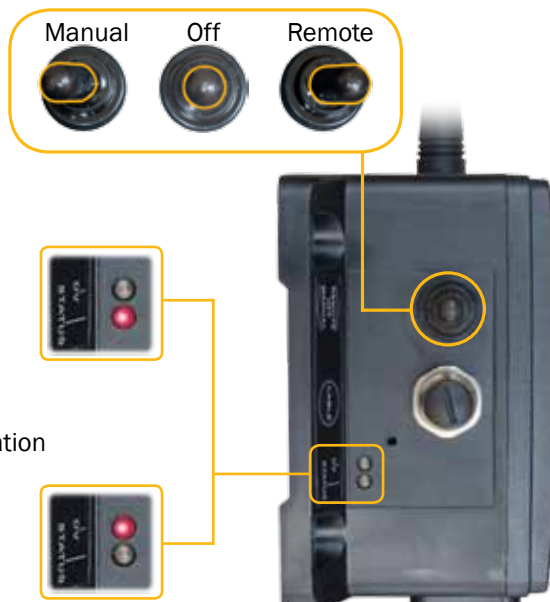

### 4.3 Central Unit G3B definition

The illustrations below aims to declare all entities mentioned in this document.



#### Activating the Central Unit G3B

The Central Unit G3B is supplied thru Cable A and requires external power switching, see chapter 5.8 for further info.

The Central Unit G3B exists in 2 different versions; one with 2 cable outputs and one with 3 cable outputs. Refer to chapter 5.8 for further info.

#### 4.4 Cable or radio communication

Cable communication has higher priority than radio communication, if a cable link is present between the PCU and Central Unit this will be detected by the system, disabling radio communication.

#### 4.5 Cable connection schematics

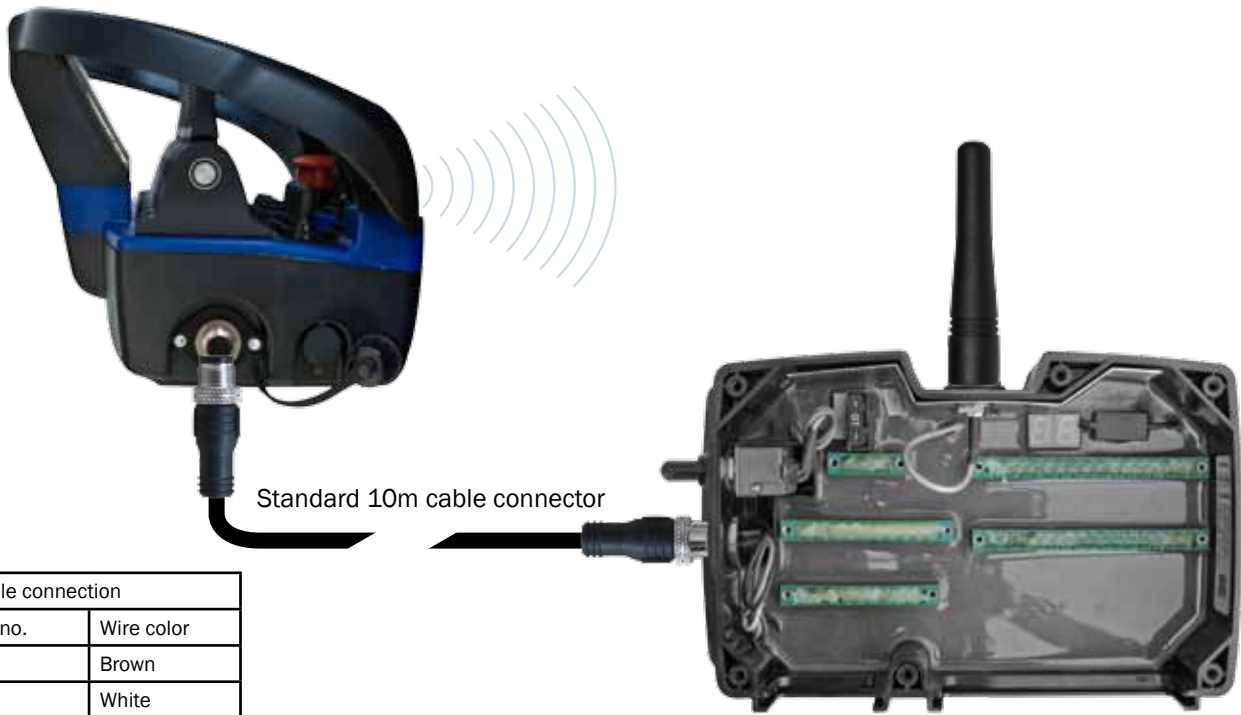

Cable connection	
Pin no.	Wire color
1	Brown
2	White
3	Blue
4	Black
5	Grey

#### Portable Control Unit Pin assignments

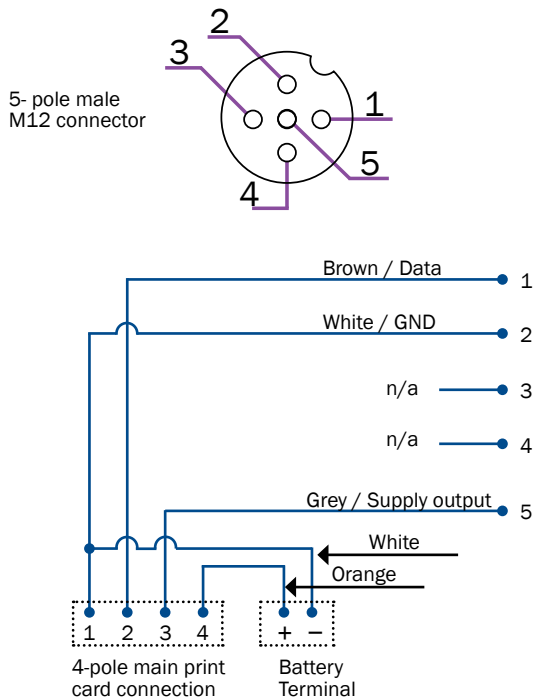

#### Central Unit G2B/G3B Pin Assignments

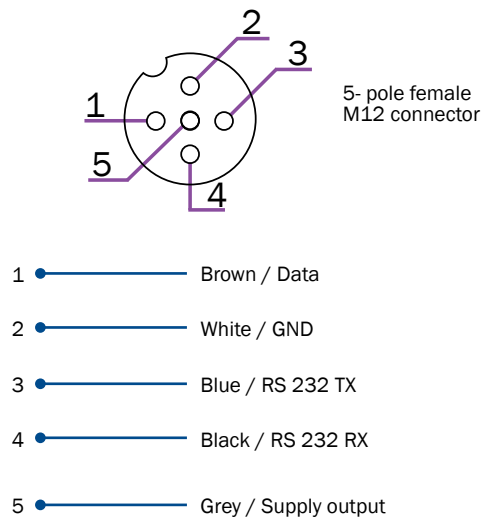

## 5 Inputs & Outputs

### 5.1 Analogue functions

The analogue inputs available for each platform (MAXI Linear, MAXI Joystick, MINI Linear and MINI Joy stick) are by default assigned an analogue output on the Central Unit, below figures declares the standard assignments.

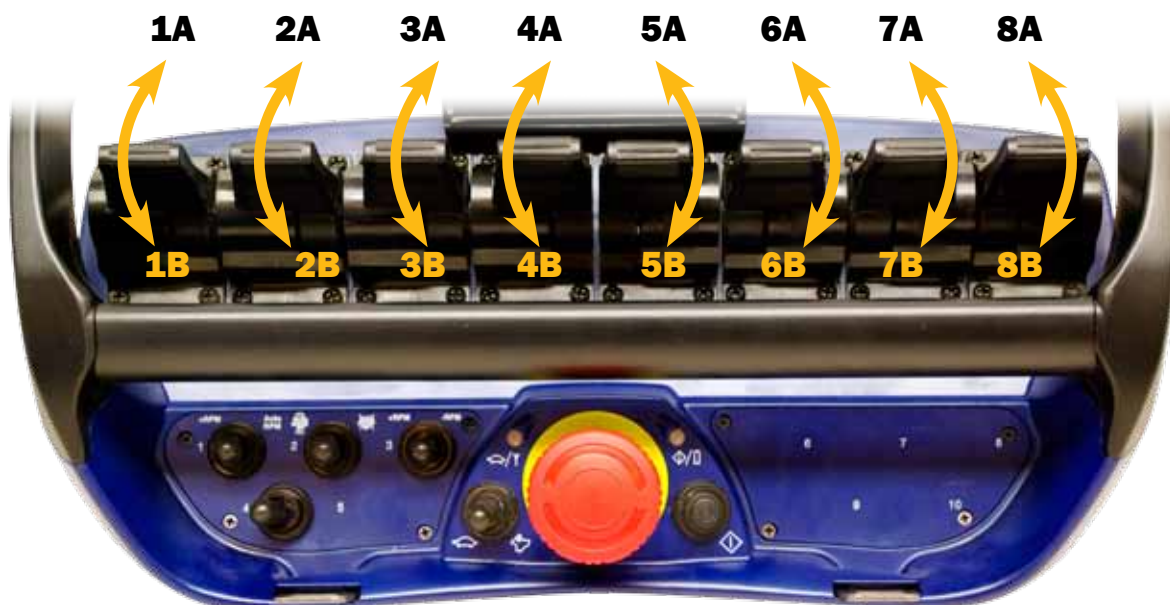

PCU MAXI Linear standard assignments

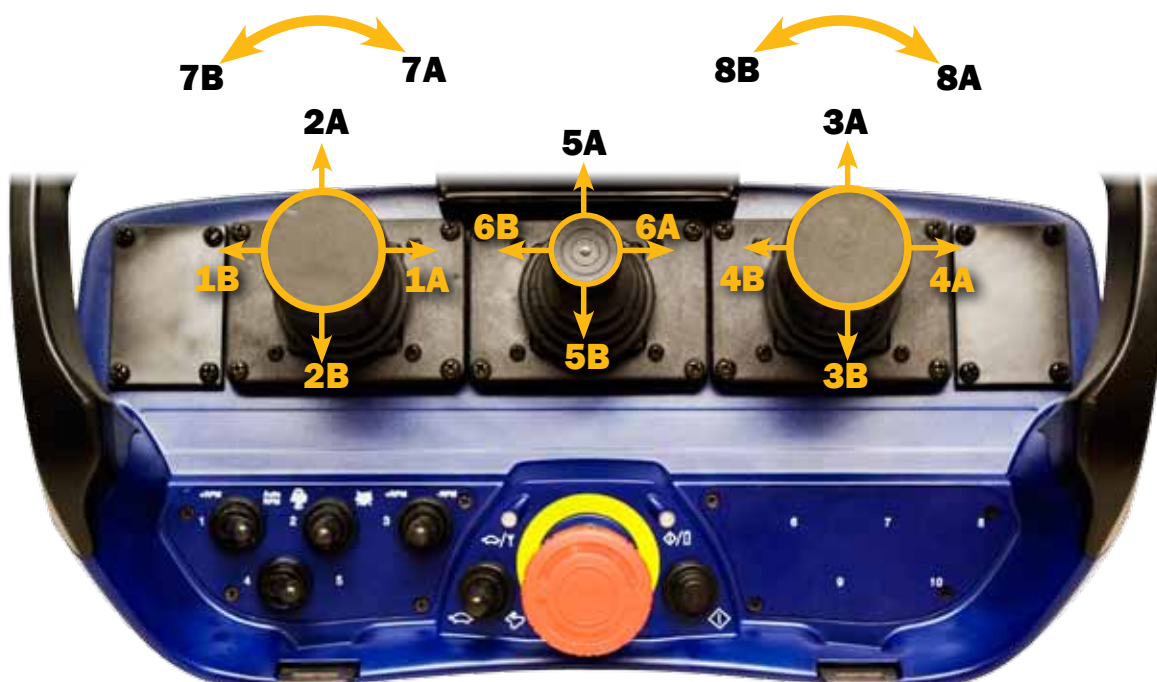

PCU MAXI Joystick standard assignments

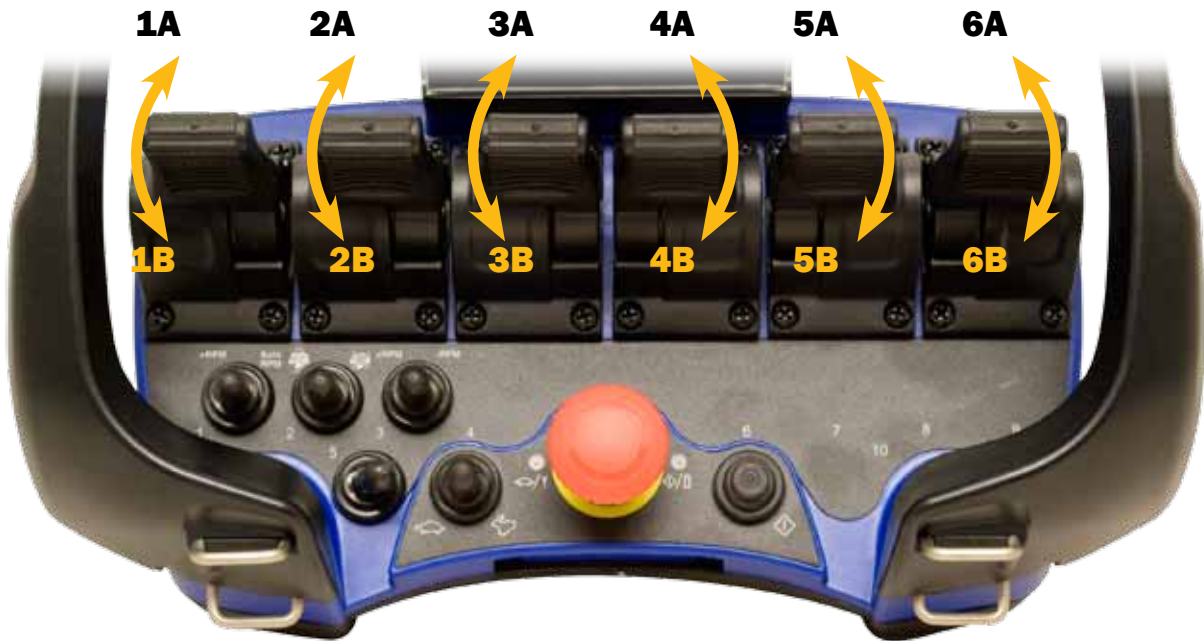

PCU MINI Linear standard assignments



PCU MINI Joystick standard assignments

## 5.2 Portable Control Unit MAXI digital inputs

The digital inputs available are NOT all by default assigned an digital output on the Central Unit, below figures only declares digital input access.

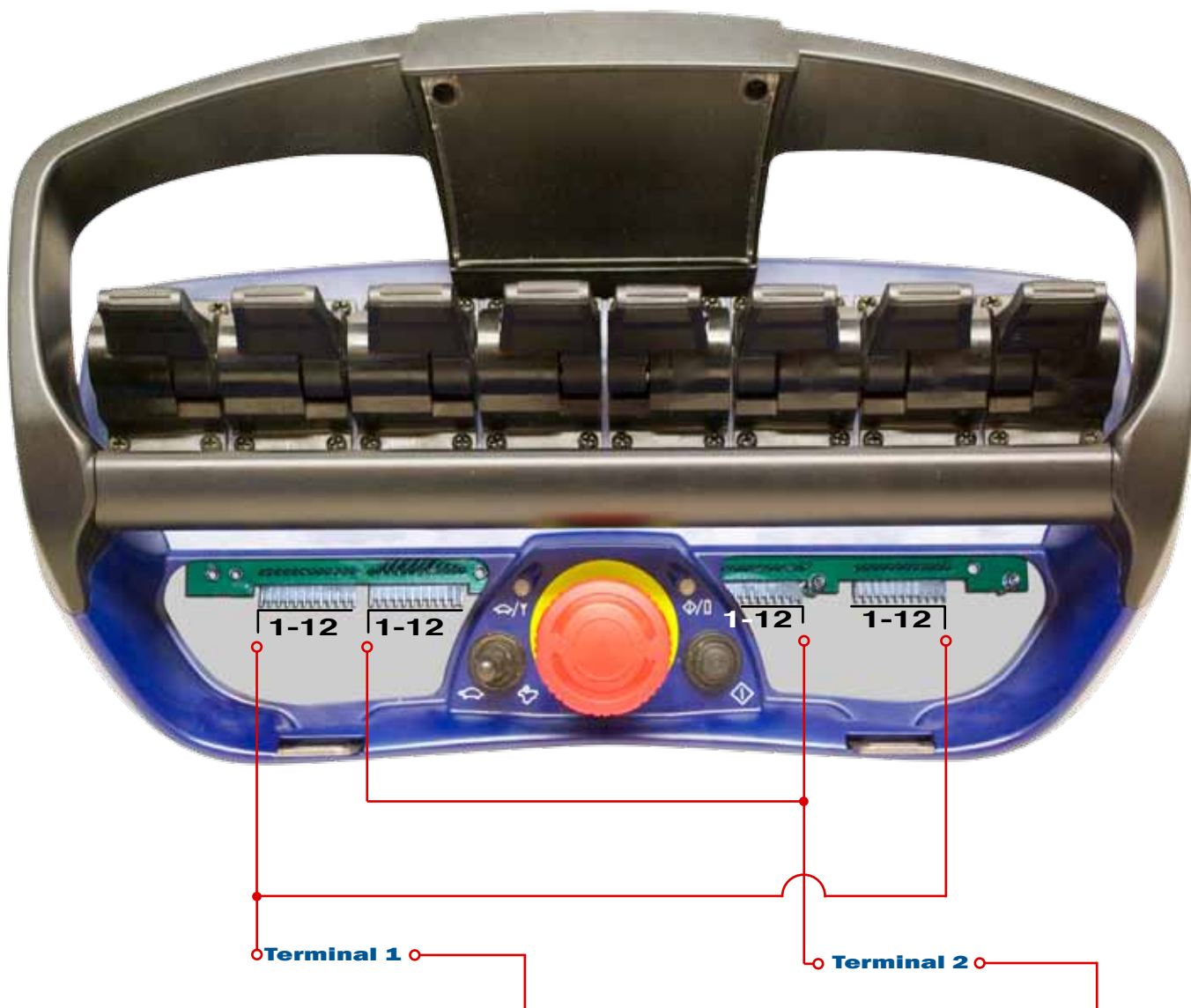

No.	Type	Colour code	AMP Pin no.
-	Common (GND)	Black	1
10	Digital input 33	Pink	2
9	Digital input 06	Grey	3
8	Digital input 02	Brown	4
7	Digital input 32	Purple	5
6	Digital input 05	Orange	6
5	Digital input 31	Black	7
4	Digital input 07	White	8
3	Digital input 04	Blue	9
2	Digital input 03	Green	10
1	Digital input 01	Yellow	11
-	Supply output	Red	12

No.	Type	Colour code	Amp Pin no.
-	Common (GND)	Black	1
20	Digital input 36	Pink	2
19	Digital input 35	Grey	3
18	Digital input 34	Brown	4
17	Digital input 37	Purple	5
16	Digital input 08	Orange	6
15	Digital input 09	Black	7
14	Digital input 13	White	8
13	Digital input 12	Blue	9
12	Digital input 11	Green	10
11	Digital input 10	Yellow	11
-	Supply output	Red	12

Note that on the MAXI platform the Terminals 1 and 2 are mirrored and available on both left and right hand side of the stop button



### 5.3 Portable Control Unit MINI digital inputs

The digital inputs available are NOT all by default assigned an digital output on the Central Unit, below figures only declares digital input access.

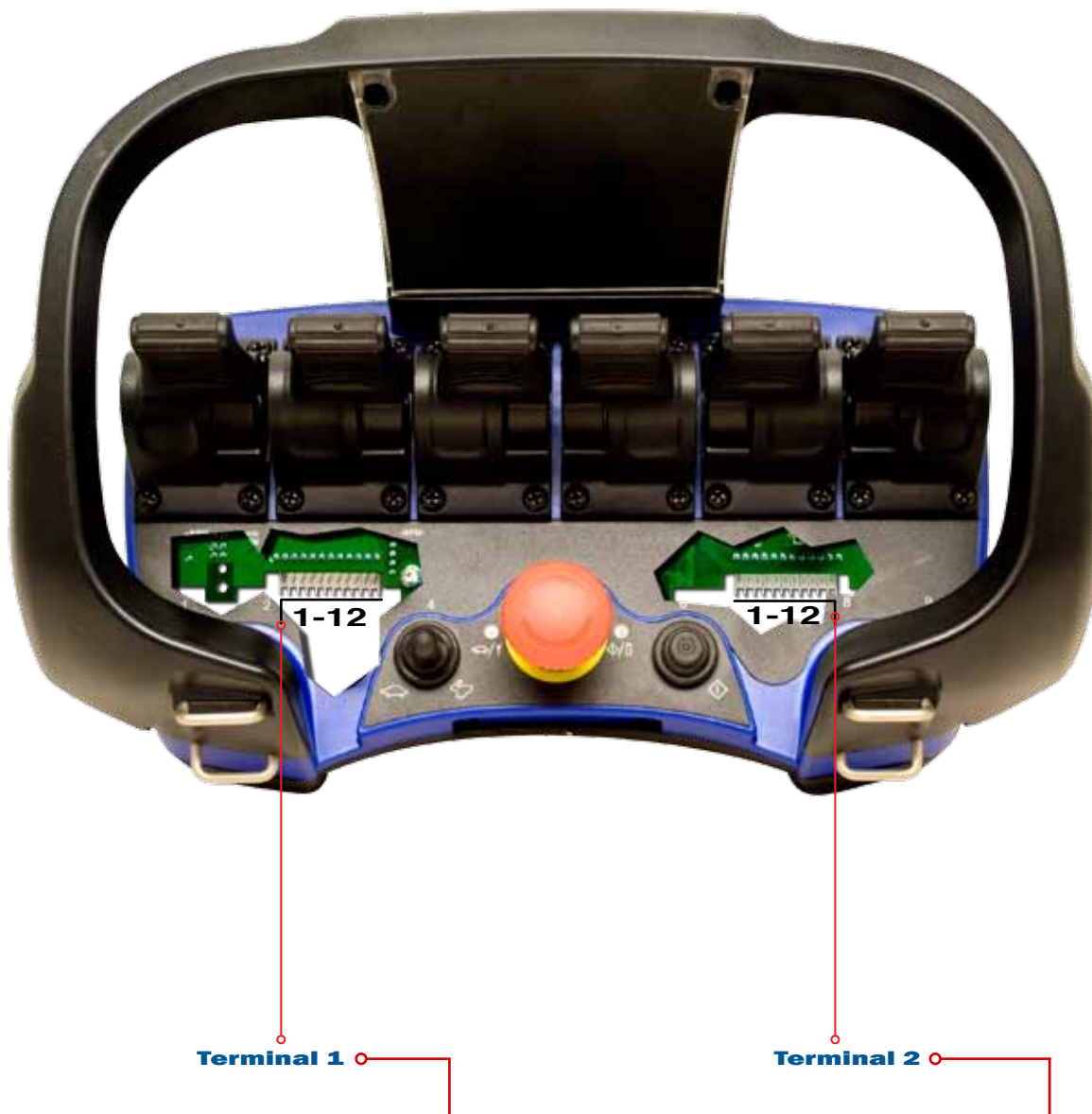

No.	Type	Colour code	AMP Pin no.
-	Common (GND)	Black	1
10	Digital input 33	Pink	2
9	Digital input 06	Grey	3
8	Digital input 02	Brown	4
7	Digital input 32	Purple	5
6	Digital input 05	Orange	6
5	Digital input 31	Black	7
4	Digital input 07	White	8
3	Digital input 04	Blue	9
2	Digital input 03	Green	10
1	Digital input 01	Yellow	11
-	Supply output	Red	12

No.	Type	Colour code	Amp Pin no.
-	Common (GND)	Black	1
20	Digital input 36	Pink	2
19	Digital input 35	Grey	3
18	Digital input 34	Brown	4
17	Digital input 37	Purple	5
16	Digital input 08	Orange	6
15	Digital input 09	Black	7
14	Digital input 13	White	8
13	Digital input 12	Blue	9
12	Digital input 11	Green	10
11	Digital input 10	Yellow	11
-	Supply output	Red	12

## 5.4 Digital functions

The digital functions utilized varies depending on system configuration, up to 20 digital functions can be implemented thru left- and/or right switch panels with programmable assignments to up to 14 digital outputs.

In excess the On-button may also be assigned a digital output.

Below shows PCU platforms standard digital inputs and default Central Unit output assignment



PCU MINI Standard assignment



PCU MAXI Standard assignment

Position	Type	Central Unit
301	3 way detent toggle	Digital output 1 / Digital output 1 Parallel with analogue input movement (AutoRPM engine feature)
302	3 way spring back toggle	Digital output 2 / Digital output 3 (Engine start / Engine stop)
303	3 way spring back toggle	Digital output 4 / Digital output 5 (Engine RPM+ / Engine RPM-)
304/305	2 way detent toggle	Digital output 6 (Optional)
On-button	Push button	Digital output 7

### 5.5 Terminal schematics for current controlled Central Unit G2B

The drawing below declares access points for each available input and output both from the inside terminal (above) and the standard cable kits (below). Standard cable wire number/markings is also declared.

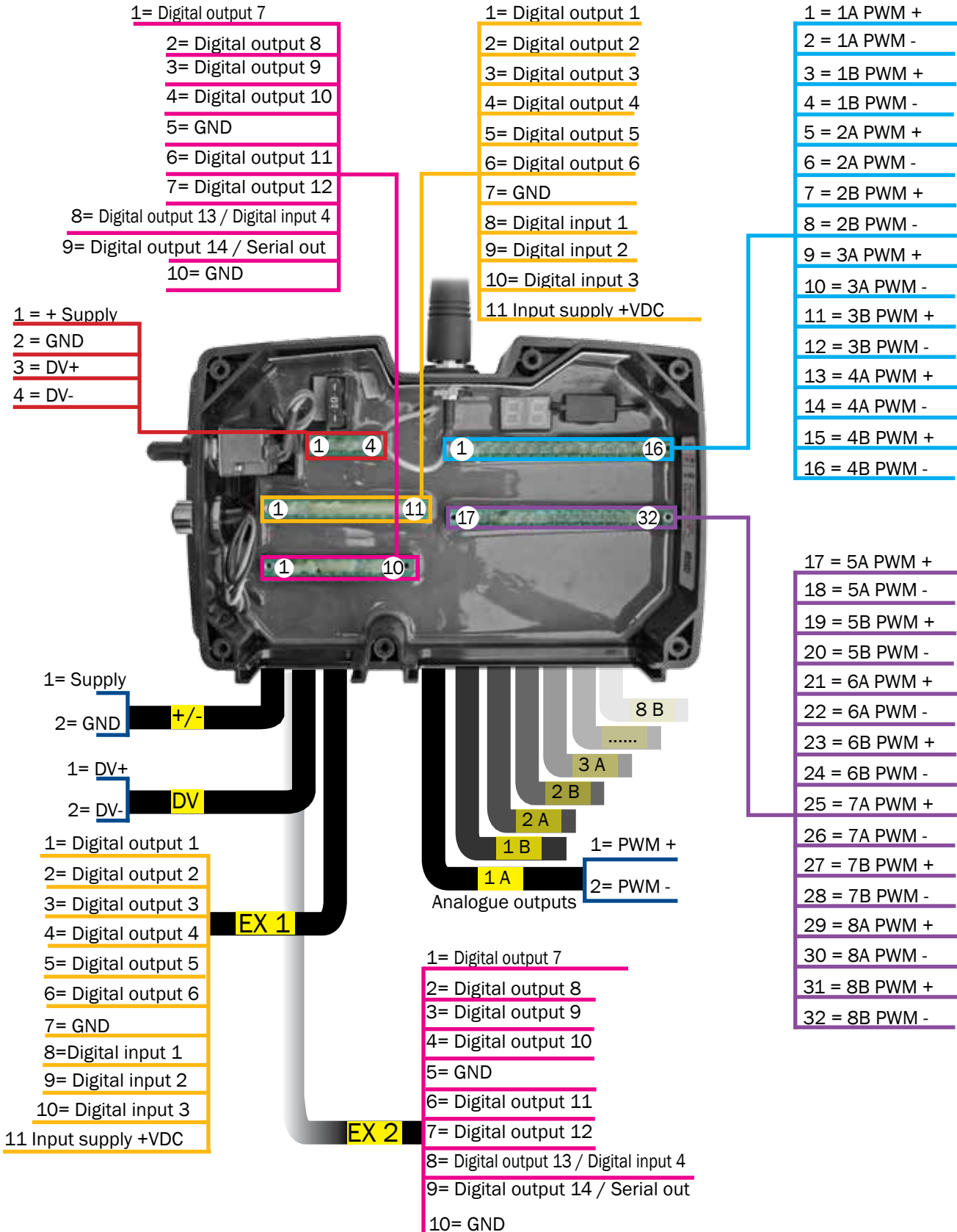

### 5.6 Terminal schematics for voltage controlled Central Unit G2B

The drawing below declares access points for each available input and output both from the inside terminal (above) and the standard cable kits (below). Standard cable wire number/markings is also declared.

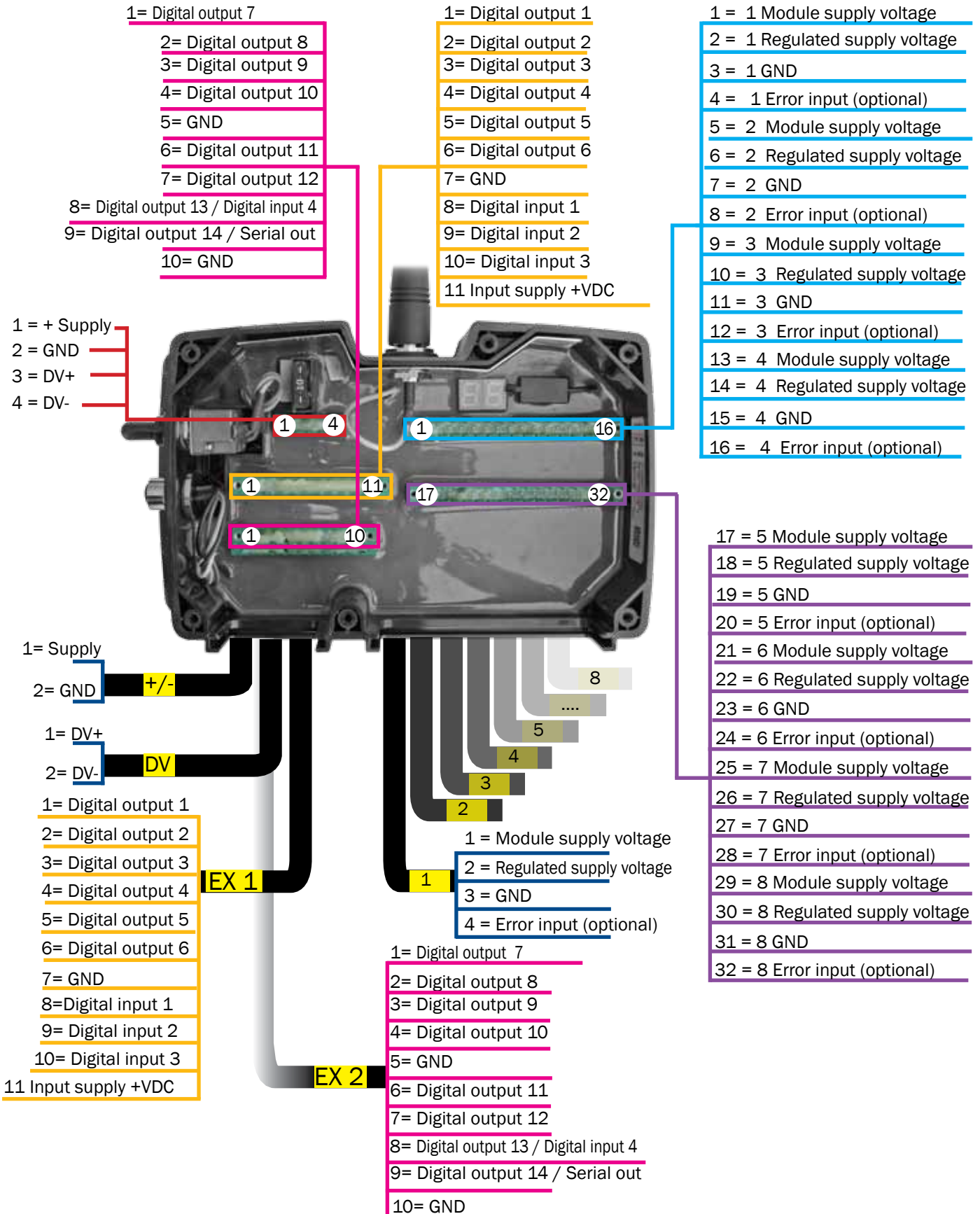

## 5.7 Terminal schematics for Central Unit G2B CAN interface

The Central Unit is equipped with terminal connections for CAN. The drawing below declares the access points both from the inside terminals (above) and the standard cable kit (below).

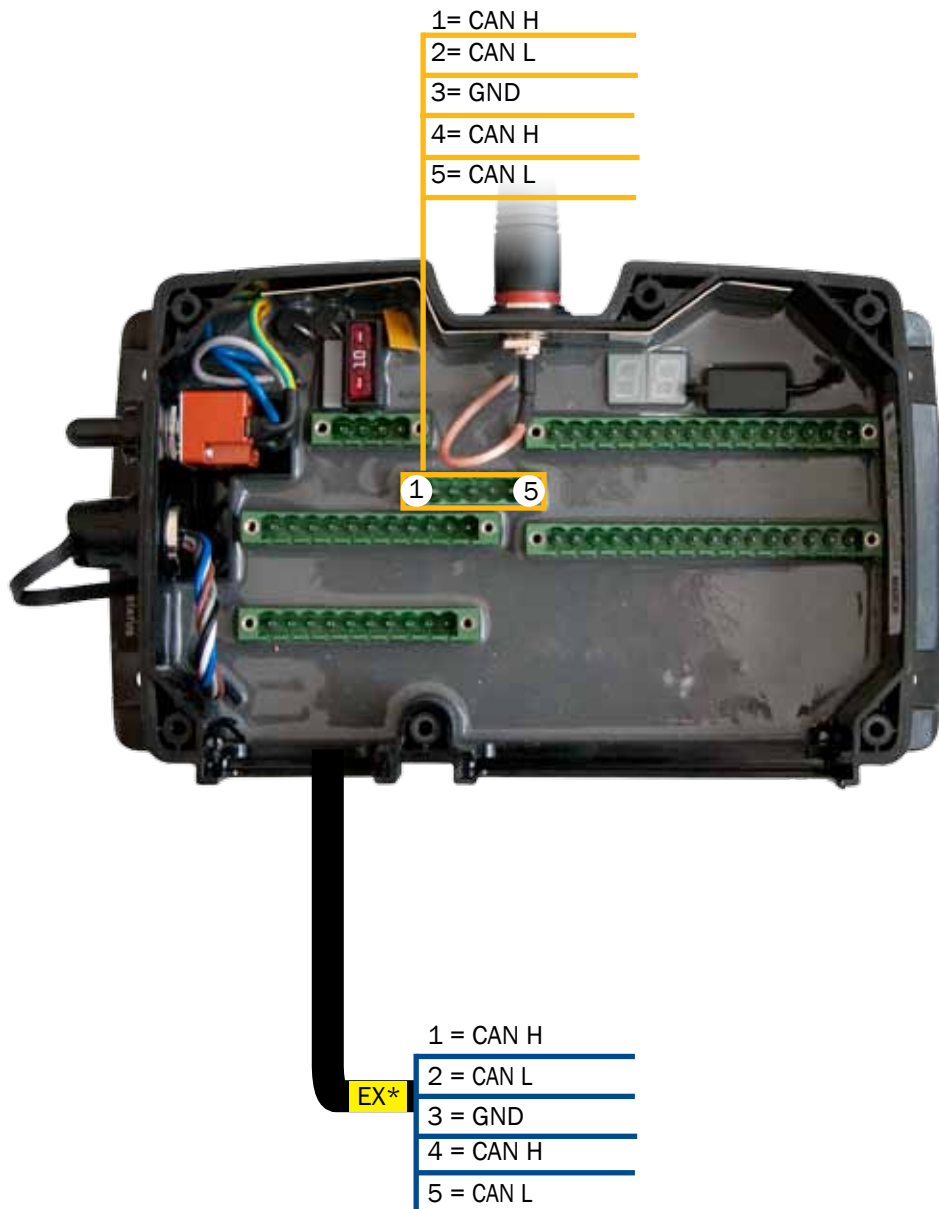

NOTE:

\* as various cable kits exist, please refer to chapter 13 or system technical specification for further information

The Central Unit G2B is not equipped with a specific "STOP loop" connection, if needed a digital output are in such cases assigned; if more info is required; refer to system technical specification.

If required; a terminator resistor can be installed between points 4 & 5: the resistor value needs to be defined by the system installer.

### 5.8 Connection schematics for Central Unit G3B

The Central Unit G3B is equipped with either 2 or 3 circular M12 5-pole connectors (check item no). The drawing below declares Pin-assignments for both versions of the Central Unit G3B



Item no: 1602, 1603

Item no: 1604, 1605

#### Cable A (3 meters)

Connection	
Pin no.	Colour / Function
1	Brown / DV1
2	White / Power supply
3	Blue / GND
4	Black / CAN_HIGH
5	Grey / CAN_LOW



#### Cable B (3 meters)

Connection	
Pin no.	Colour / Function
1	Brown / DATA
2	White / GND
3	Blue / RS 232 TX
4	Black / RS 232 RX
5	Grey / Supply output

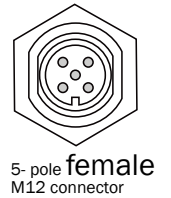

#### Cable C (3 meters)

Connection	
Pin no.	Colour / Function
1	Brown / DV2
2	White / LOOP1_OUT
3	Blue / LOOP1_IN
4	Black / LOOP2_OUT
5	Grey / LOOP2_IN



## 6 Operational indications

### 6.1 Central Unit status and operational indications

The Central Unit G2B is equipped with 2 individual positions where status and operational indications can be read, the external LEDs STATUS and DV provides basic limited information whilst the LED display provides more detailed information, the Central Unit G3B only have the LED-display as shown below.



Position 4: Status LEDs

Position 5: LED-display

#### External LEDs (on Central Unit G2B only!)

LED STATUS	Meaning
OFF	Off, Central Unit is deactivated
RED	ON - Central Unit is activated in REMOTE mode No communication with PCU
GREEN	ON - Central Unit is activated in REMOTE mode Communication link with Portable Control Unit
RED flashing 4/1	Error code being displayed on internal LED Display

LED DV	Meaning
RED	Dump Valve output is supplied

Note that the LED STATUS is used also for error code alarms and operator controlled functions and is then triggered by an event, the type of indication will be declared for each event further in this document.

## 6.2 Central Unit LED-display

Below table shows the variety of status indications available for both the Central Unit G2B and G3B:

LED Display	Meaning
	Off, deactivated
	Standby mode, no communication link with PCU
	Standby mode, communication link with PCU
	Communication link via cable, ID-code approved
	Communication link via cable, ID-code not approved
	Communication link via radio, frequency hopping
	Communication link via radio, frequency locked on channel 1
	Communication link via radio, frequency locked on channel 2
	Communication link via radio, frequency locked on channel 3
	Communication link via radio, frequency locked on channel 4
	Communication link via radio, frequency locked on channel 5
	Communication link via radio, frequency locked on channel 6
	Communication link via radio, frequency locked on channel 7
	Communication link via radio, frequency locked on channel 9
	Communication link via radio, frequency locked on channel 10
	Communication link via radio, frequency locked on channel 11
	Communication link via radio, frequency locked on channel 12
	Communication link via radio, frequency locked on channel 13
	Radio communication deactivated via program setting (WinSCI)
	ID-programming procedure is active (See chapter 12 for further info)
	ID-programming procedure rejected (See chapter 12 for further info)



### 6.3 Portable Control Unit status indications

The Portable Control Unit uses 2 LEDs to indicate operational status, the Portable Control Unit is also equipped with an internal buzzer that emits sounds and alarms when required.



Typical status indications involving the Micro- and Power-LED are declared below:

Power-LED	Meaning
OFF	Off, Portable Control Unit is deactivated
RED Fixed	ON – Transmitting data
RED Flashing 1/1 sec.	ON – Transmitting data Low battery! (Buzzer will emit an alarm for the first three sequences when low level is detected)

Micro-LED	Meaning
OFF	Normal mode
Green Flashing 1/3th sec.	Micro step 1 active
2 / 3rd sec	Micro step 2 active
3 / 3rd sec	Micro step 3 active
4 / 3rd sec	Micro step 4 active
5 / 3rd sec	Micro step 5 active

Note that these LEDs are used also for error code alarms and operator controlled functions and are then triggered by an event, the type of indication will be declared for each event further in this document.

# 7 Error code indications

---

## 7.1 General description

Both the Portable Control Unit and the Central Unit are embedded with constant fault monitoring, any errors noticed by the system will result in interruption of all operational commands.

## 7.2 Central Unit Error codes

All of the Central Units outputs are fault monitored for short circuits and/or overloads, in the event of an error being detected the Central Unit will alert that an error has occurred via the external LED Status and indicate the appropriate error code via the LED-display, the Central Unit will then reset to operational mode if possible.

Below example flowchart on behaviour:

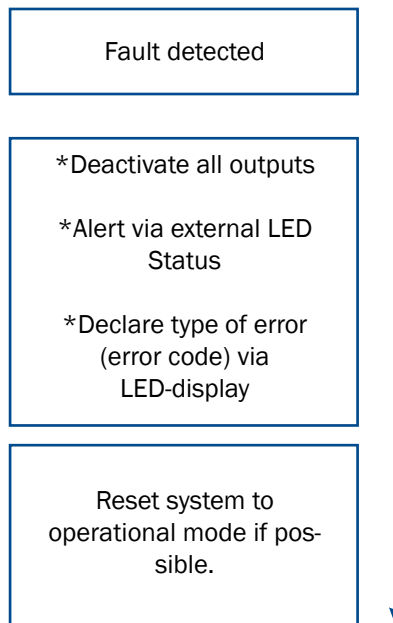

This fault sequence will take an approximately 6 seconds The external LED STATUS will flash rapidly in red colour declaring that an error has been detected, for more detailed information; the LED-display must be monitored (or error code log available from diagnostics menu).

The LED-display Error codes are displayed in up to 3 sequences, this allows the Central Unit to declare exactly which output that is related to the error (where applicable).

First sequence: Letters E:r is presented declaring an error code

Second sequence: Type of error code

Third sequence: Additional information (where applicable)

In example:

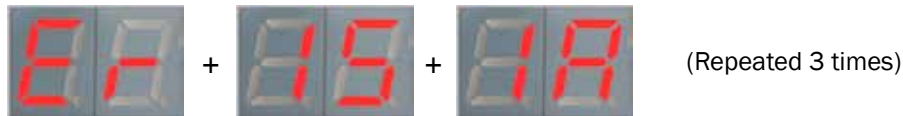

The example would imply that there is an short circuit on output 1A

### 7.2.1 Error codes

2nd	3rd	Description	Cause	Action
01.	01	EEPROM failure.	Incorrect checksum on EEPROM, last stored data will be set.	Reset system, if persistent; Re-load application program.
01.	02	Flash memory failure.	Incorrect checksum on flash memory.	Reset system, if persistent; Re-load application program.
01.	03	Stack memory failure.	Incorrect sizes of data in CANopen protocol, incorrect dataflow or stack overflow.	System will self reset automatically. If persistent; Re-load application program.
01.	04	RAM memory failure.	Incorret RAM and/or hardware identification.	System will self reset automatically. If persistent; Re-load application program.
02.	01	Illegal voltage; DVoutput.	DV-output error; DV-output (DV+) externally supplied	System will self reset. Check DV-output connection. Remove terminal connector and reset system.
02.	02	Short circuit; DV-output.	DV-output error; DV output (DV+) short circuited or overloaded.	System will self reset. Check DV-output connection. Remove terminal connector and reset system.
02.	03	Safety switch error	Safety switch output read back error, incorrect voltage (High instead of Low)	System will self reset. Remove all terminal connectors and reset system.
02.	04	Safety switch error	Safety switch output read back error, incorrect voltage (Low instead of High)	System will self reset. Remove all terminal connectors and reset system.
03.	00	Illegal voltage; Digital output	Digital output (1-14) illegal voltage, expected low signal but read as high (Could be any of the available 14	System will self reset. Check digital output connections. Remove terminal connector and reset

### 7.2.1 Error codes (continued)

2nd	3rd	Description	Outputs	system
04.	00	Short circuit; Digital output	Digital output (1-14) short circuited or overloaded (Could be any of the available 14 outputs)	System will self reset. Check digital output connections. Remove terminal connector and reset system.
05.	00	Error input triggered (Danfoss CU only).	Error signal for Danfoss valve triggered (Could be any of the available 8 inputs)	System will self reset. Check analogue output connections. Remove terminal connector and reset system.
06.	x	Illegal voltage analogue output	Wrong voltage on analogue output (3rd sequence declares related output; 1A,1B....).	System will self reset. Check analogue output connections. Remove terminal connector and reset system.
07.	x	Illegal voltage analogue output	Wrong current on analogue output (3rd sequence declares related output; 1A,1B....).	System will self reset. Check connections. Remove terminal connector and reset system.
08.	01	CAN Passive	CAN bus in passive mode.	System will self reset. Check CAN connections. Check other nodes on bus and reset system.
08.	02	CAN I/O Buffer overflow	CAN overrun; either the CAN input or CAN output buffer are full	System will self reset. Reset system, re-initiate via CAN controller.
08.	03	CAN physical layer error	Bad communication/transmission	System will self reset. Check CAN connections. Check other nodes on bus and reset system.
08.	04	CAN PDO length exceeded	PDO length is too long	System will self reset. Reset system, re-initiate via CAN controller.
08.	05	CAN PDO length error	PDO length is too short	System will self reset. Reset system, re-initiate via CAN controller.
08.	06	CAN Transmit COB-ID collision	To many collisions on CANbus	System will self reset. Check CAN connections. Check other nodes on bus and reset system, re-initiate via CAN controller.
10.	00	PCU failure; Emergency stop	Error transmitted from PCU: Illegal signal from PCU emergency stop switch	System will self reset. Check emergency stop switch on PCU
11.	00	PCU failure; Analogue input	Error transmitted from PCU: Analogue input active on start-up input	System will self reset. Ensure all analogue inputs on PCU are at zero/neutral position. Restart PCU.
12	00	PCU failure; Analogue input	Error transmitted from PCU: Signal redundancy test; illegal signal from analogue input.	System will self reset; Diagnose PCU via TEST MODE
13.	n/a	PCU failure; Analogue input	Error transmitted from PCU: Signal redundancy test; illegal signal from analogue input.	System will self reset; Diagnose PCU via TEST MODE

### 7.2.1 Error codes (continued)

14.	01	ID programming failure	ID-code and/or parameter settings not accepted.	System will self reset. Verify ID-programming procedure. Reset application program.
14.	02	Program failure	Programmable logic parameter error	System will self reset. Reset application program.
15.	x	PWM output failure	Analogue output short circuited or overloaded. (3rd sequence declares related output; 1A,1B....).	System will self reset. Check analogue output connections. Remove terminal connector and reset system.
16.	x	PWM output failure	Analogue output not connected (Programmable feature). (3rd sequence declares related output; 1A,1B....).	System will self reset. Check analogue output connections. Remove terminal connector and reset system.
17.	01	Low supply power	Low power supply (Below 8,5 VDC)	System will self reset. Check power supply and supply connections.
17.	02	High supply power	High power supply (Above 36,0 VDC)	System will self reset. Check power supply and supply connections.
98.	n/a	Undefined PCU error	Undefined error in PCU.	Diagnose PCU via TEST MODE
99.	n/a	Undefined CU error	Undefined error in CU.	System will self reset. Remove all terminal connectors Check power supply and supply connections. Reset system.

### 7.3 Portable Control Unit error codes

The Portable Control Unit monitors all analogue and digital inputs for faults and uses the Power-LED and BUZZER to indicate alarms.

Below available error codes:

Indications	Meaning
1	Analogue input 1 not at zero position during start-up
2	Analogue input 2 not at zero position during start-up
3	Analogue input 3 not at zero position during start-up
4	Analogue input 4 not at zero position during start-up
5	Analogue input 5 not at zero position during start-up
6	Analogue input 6 not at zero position during start-up
7	Analogue input 7 not at zero position during start-up
8	Analogue input 8 not at zero position during start-up

## 8 Radio

### 8.1 General description

Radio is used as a bus link for data packages between the transmitter (Portable Control Unit) and receiver (Central Unit), the radio continuously transmits the positions of the analogue and digital inputs available on the Portable Control Unit to the Central Unit for further processing.

The digitalized data transfer protocol uses a high security level for verification of each data package, no loss of individual functions due to radio interferences can occur.

The unique ID-code held in the Portable Control Unit ensures that the system can not be operated unintentionally by other Control Unit.

The transmission allows interferences to some extent as long as multiple data packages are not interfered successively.

### 8.2 Determining radio quality

The radio quality can be determined by the external status LED and/or the first 7-segment on the LED-display during radio communication

When an optimal communication is acquired the external Status LED will be fixed green and the Central Unit LED-display will indicate "1x" (x being dependent on program setting).

Short interruptions and losses of data packages will be indicated by irregular flashes of these indicators, an increasing intensity of flashes indicates a decreasing radio reception.

Note that irregular flashes is a common occurrence, unless they cause an interruption in communication they should not be considered a cause for concern.



NOTE:

In such cases that a locked frequency is used the second 7-segment indication will be different, check chapter 6.2 for further information.

### 8.3 Radio channel / Frequency

Refer to separate document for radio channel used in your region

### 8.4 Range

Refer to separate document for radio channel used in your region

## 9 Diagnostics mode

### 9.1 General description

A diagnostics mode has been made available as to diagnose and manage the system, the LED-display is required to be monitored during diagnostics and will allow operator to read out recently occurred error codes, output characteristics and program information in order to diagnose the system.

### 9.2 Activating diagnostics mode

Note that the LED-display is required to be monitored during diagnostics mode.

Do as follows:

1. Remove the battery pack. Connect the cable between the Portable Control Unit and turn off the Central Unit via the R/M-switch.
2. Activate the Central Unit in REMOTE mode.
3. Press the Portable Control units On-button once.  
-The Power-LED should be illuminated
4. Produce impulses in very quick succession with the Micro-toggle to the LEFT (MICRO-ON direction) 15 times or until the Central Units LED-display indicates D:i – 0:0.
5. Diagnostics mode is now active!

The diagnostics mode consist of 8 different menus' that can be toggled using the on-button, once a menu is entered the current values for that specific parameter is presented in the LED-display.

To exit diagnostics mode press Stop-button on Portable Control Unit.



If activation fails, the 4th step may have been done too slow, the toggle has to be done with a maximum 0,5 second interval.

**Attention:**

Note that system will operate outputs as in normal operational mode, real-time values (where available) are shown in the LED-display.

Note that by entering the diagnostics mode, the Micro function has been activated and analogue outputs may operate reduced speeds, if full speeds are desired; press Micro-toggle to the right once (MICRO-OFF direction).

### 9.3 Table / diagnostics data

Position / LED Indication	Meaning
D:i - 0:0	Default position
D:i - 0:1	Analogue output status
D:i - 0:2	Digital output status
D:i - 0:3	Digital Input status
D:i - 0:4	Error code Log
D:i - 0:5	Program save
D:i - 0:6	Program load
D:i - 0:7	Central Unit firmware version
D:i - 08	Portable Control Unit firmware version
-	Return to position 00

#### 9.3.1 Position 1 - Analogue output status

Press On-button once from position D:i – 0:0

D:i – 0:1 is displayed

As to determine the current status for all analogue outputs. Lever/joystick assignments and analogue output start, stop and ramp values.

While in this position, actuating a specific lever will result in the LED-display presenting which output that is assigned, the direction and the current real time value.

In example:

Lever is actuated, display responds by indicating related output for 1 second

In example

1:A, 2:A, 3:A, 4:A, 5:A, 6:A, 7:A, 8:A, 1:b, 2:b, 3:b, 4:b, 5:b, 6:b, 7:b, 8:b

Followed by the current value in correspondance to lever angle.

1-99, h:i\*

\*h:i indicating that 100% velocity is achieved



### 9.3.2 Position 2 - Digital output status

Press On-button two times from position D:i – 0:0

D:i – 0:2 is displayed for 1 second, the LED-display will then toggle all Central Unit digital outputs and present current value (High or Low)

O:n – 0:1 - 0:1 or 0:0 (High/Low)

O:n – 0:2 - 0:1 or 0:0 (High/Low)

O:n – 0:3 - 0:1 or 0:0 (High/Low)

...

O:n – 1:4 = 0:1 or 0:0 (High/Low)

As to determine the current status for all digital outputs.

While in this position the LED display will present each digital output from 1 to 14, high or low, continuously

### 9.3.3 Position 3 - Digital input status

Press On-button three times from position D:i – 0:0

D:i – 0:3 is displayed for 1 second, the LED-display will then toggle all Central Unit digital inputs and present current value (High or Low).

i:n – 0:1 - 0:1 or 0:0 (High/Low)

i:n – 0:2 - 0:1 or 0:0 (High/Low)

i:n – 0:3 - 0:1 or 0:0 (High/Low)

i:n – 0:4 - 0:1 or 0:0 (High/Low)

As to determine the current status for all digital inputs.

While in this position the LED-display will present each digital input from 1 to 4, high or low, continuously

### 9.3.4 Position 4 - Error code log

Press On-button four times from position D:i – 0:0

D:i – 0:4 is displayed for 1 second, the LED-display will then toggle the 5 most recent error codes that have been triggered in the Central Unit.

As to determine faults registered by the Central Unit, refer to chapter 7 for error code information.

The LED-display will toggle the logged error codes continuously.

#### 9.3.4.1 Clear error code log

Hold Micro-toggle in LEFT position for 5 seconds

E:r – C:L is displayed in the LED-display (Error Clear)

Release and press Micro-toggle once more to LEFT position to confirm.

Central Unit error code logg is cleared.

An error code clear is suitable to conduct after service!

### 9.3.5 Position 5 - Program save

Press On-button five times from position D:i – 0:0

D:i – 0:5 is displayed

Press and hold Micro-toggle in LEFT position for 3 seconds

C:o – F:A is displayed

Release and press Micro-toggle once more to LEFT position to confirm and store the current settings

Saves the current settings for DIRECTION and SPEEDS (START, STOPP, MICRO, RAMP) and DV-delay time as back-up for eventual future program load, see below chapter “program load”.

### 9.3.6 Position 6 - Program load

Press On-button six times from position D:i – 0:0

D:i – 0:6 is displayed

Press and hold Micro-toggle in LEFT position for 3 seconds

P:o – F:A is displayed

Release and press Micro-toggle once more to LEFT position to confirm and load the settings previously stored

Enables a reset to previously stored application program setting “Program save”

### 9.3.7 Position 7 - Central Unit program version

Press On-button seven times from position D:i – 0:0

D:i – 0:7 is displayed followed by current firmware version

V:n – n:n

The current version of the Central Units program is presented in two sequences, continuously repeated

In example:



### 9.3.8 Position 8 - Portable Control Unit program version

Press On-button eight times from position D:i – 0:0

D:i – 0:8 is displayed followed by the current firmware version

V:n – n:n

The current version of the Portable Control Units program is presented in two sequences, continuously repeated

# 10 Online Programming mode

---

## 10.1 General description

The Scanreco RC 400 offers considerable possibilities for system constructors of hydraulically driven mobile cranes and machines. The program in the control system is very comprehensive, flexible and has many adaptation possibilities for specific applications. The control system offers simple programming of a number of functions which can easily be turned on or off or altered during operation.

To obtain the best manoeuvre characteristics in the simplest way, all programming / calibration of manoeuvre characteristics is made during operation (so called on-line programming). All programming / calibration is made from the Portable Control Unit.

Programming is simple and does not require tools / instruments.

**The installer/system designer is responsible for seeing that system is used correctly and is responsible for any re-programming of the system functions and the characteristics changes caused by this!**

The system has 4 levels of authorisation:

**Authorisation level 1.** (Installer)

Change direction of analogue movement

**Authorisation level 2.** (Well trained installer, well trained service personnel)

Change direction of analogue outputs A/B

Change start speeds for analogue outputs

Change stop speeds for analogue outputs

Change micro speed for analogue outputs

Change ramp speeds for analogue outputs

**Authorisation level 3.** (Well trained crane and valve manufacturer, well trained system constructor)

Not declared in this document

**Authorisation level 4.** (Scanreco AB)

Not declared in this document

**IMPORTANT SAFETY NOTE:**

In online programming mode, when you select a programming step, the system automatically activates the speeds of the corresponding selected lever. Speeds used are independent by SET selected in the system and depend only by programming step in which you are.

**EXAMPLE:**

Even if the system is working in SET1 (SET1 argument is valid), when you enter in the programming mode step no. 8 (SET2), the system will activate and work with the speeds of SET2

## 10.2 Activating online programming mode

The Central Units LED-display or Portable Control Units acoustic step signalling is required to be monitored during programming mode, check the table (10.3) for the indications given.

Do as follows:

1. Remove the battery pack. Connect the cable between the Portable Control Unit and the Central Unit and test run the system.
2. Press the Stop-button on the Portable Control Unit and deactivate the Central Unit via the R/M-switch.
2. Twist up the Stop-button on the Portable Control Unit and activate the Central Unit in REMOTE mode.
3. Press the Portable Control Units On-button once.  
-The Power-LED should be illuminated
4. Produce impulses in very quick succession with the Micro-toggle to the RIGHT (MICRO-OFF direction) 10 times or until the Portable Control Unit gives a long beep signal and the Central Units LED-display indicates P:o – 0:0.
5. Online programming mode is now active, The online programming mode consist of 15 different menu's that can be toggled using the On-button, once a menu is entered the Central Units LED-display will indicate the current parameter value of any actuated analogue output, MICRO-ON (left) will decrease the value and MICRO OFF (right) will increase the value.

To exit online programming mode press the Stop-button on the Portable Control Unit.



If activation fails; the 4th step may have been done too slow, the toggle has to be done with a maximum 0,5 second interval.

Attention:

Note that the system will operate outputs as in normal operational mode!

Online programming is done in real time, any parameters set are immediately effective!

If not satisfied with the new settings you may be able to retrieve previous/default parameter setting via the diagnostics mode, load program.

### 10.3 Table / Programming options

Position via CU LED Indication	PCU Acoustic signal (L=Long, S=Short)	Meaning
P:0 - 0:0	1L	Start / Default position
P:0 - 0:1	1S	Direction
P:0 - 0:2	2S	Start value SET1
P:0 - 0:3	3S	Stop value SET1
P:0 - 0:4	4S	Micro value SET1
P:0 - 0:5	1L, 1S	Ramp delay up SET1
P:0 - 0:6	1L, 2S	Ramp delay down SET1
P:0 - 0:7	1L, 3S	Start value SET2
P:0 - 0:8	1L, 4S	Stop value SET2
P:0 - 0:9	2L, 1S	Micro value SET2
P:0 - 1:0	2L, 2S	Ramp delay up SET2
P:0 - 1:1	2L, 3S	Ramp delay down SET2
P:0 - 1:2	2L, 4S	Start value SET3
P:0 - 1:3	3L, 1S	Stop value SET3
P:0 - 1:4	3L, 2S	Micro value SET3
P:0 - 1:5	3L, 3S	Dump valve delay time
-		Return to position 00

#### 10.3.1 Position 01 - Direction

For individual adjustment of the direction of lever movement  
Available values  
0 or 1 (Normal or reversed direction)

When actuating a lever/joystick the LED-display will indicate which output that is active and its corresponding direction.

Example:  
1:b - 0:1 meaning reversed direction is enabled for output 1

#### 10.3.2 Position 02 - Start speed SET1

For individual adjustment of start speed  
Available values:  
Values ranging from 1-100

When activating a lever/joystick the LED-display will indicate which output that is active and its corresponding start speed.

Example:  
2:A - 2:0 meaning that the start speed is set to 20% of the maximum velocity on output 2A

#### 10.3.3 Position 03 - Stop speed SET1

For individual adjustment of stop speed  
Available values:  
Values ranging from 1-100

When activating a lever/joystick the LED-display will indicate which output that is active and its corresponding start speed.

Example:  
3:b - h:l meaning stop speed is set to 100% of maximum velocity on output 3B

### **10.3.4 Position 04 - Micro speed SET1**

For individual adjustment of 1st step micro speed  
Available values:  
Values ranging from 1-100

When activating a lever/joystick the LED-display will indicate which output that is active and its corresponding 1st step micro speed.

Example:  
4:b - 6:0 meaning micro speed is set to 60% of maximum velocity on output 4B.

### **10.3.5 Position 05 - Start ramp SET1**

For individual adjustment of start ramp  
Available values:  
Values ranging from 0-100 (0 = No ramp delay, 1-50 = x100 ms delay/step)

When activating a lever/joystick the LED-display will indicate which output that is active and its corresponding start ramp speed.

### **10.3.6 Position 06 - Stop ramp SET1**

For individual adjustment of stop ramp  
Available values:  
Values ranging from 0-100 (0 = No ramp delay, 1-50 = x100 ms delay/step)

When activating a lever/joystick the LED-display will indicate which output that is active and its corresponding stop ramp speed.

### **10.3.7 Position 07 - Start speed SET2**

For individual adjustment of start speed  
Available values:  
Values ranging from 1-100

When activating a lever/joystick the LED-display will indicate which output that is active and its corresponding start speed.

### **10.3.8 Position 08 - Stop speed SET2**

For individual adjustment of stop speed  
Available values:  
Values ranging from 1-99

When activating a lever/joystick the LED-display will indicate which output that is active and its corresponding stop speed.

### **10.3.9 Position 09 - Micro speed SET2**

For individual adjustment of 1st step micro speed  
Available values:  
Values ranging from 1-100

When activating a lever/joystick the LED-display will indicate which output that is active and its corresponding 1st step micro speed.

### 10.3.10 Position 10 - Start ramp SET2

For individual adjustment of start ramp

Available values:

Values ranging from 0-100 (0 = No ramp delay, 1-50 = x100 ms delay/step)

When activating a lever/joystick the LED-display will indicate which output that is active and its corresponding start ramp speed.

### 10.3.11 Position 11 - Stop ramp SET2

For individual adjustment of stop ramp

Available values:

Values ranging from 0-100 (0 = No ramp delay, 1-50 = x100 ms delay/step)

When activating a lever/joystick the LED-display will indicate which output that is active and its corresponding stop ramp speed

### 10.3.12 Position 12 - Start speed SET3

For individual adjustment of start speed

Available values:

Values ranging from 1-100

When activating a lever/joystick the LED-display will indicate which output that is active and its corresponding start speed.

### 10.3.13 Position 13 - Stop speed SET3

For individual adjustment of stop speed

Available values:

Values ranging from 1-100

When activating a lever/joystick the LED-display will indicate which output that is active and its corresponding stop speed.

### 10.3.14 Position 14 - Micro speed SET3

For individual adjustment of 1st step micro speed

Available values:

Values ranging from 1-100

When activating a lever/joystick the LED-display will indicate which output that is active and its corresponding 1st step micro speed.

### 10.3.15 Position 15 - Dump valve delay time

For adjustment of the dump valve delay time

A lever/joystick is required to be actuated before value can be changed.

Available values:

Values ranging from 0-100 (0= No delay, 1-99= x100 ms delay/step, 100 = Always active\*

\*The DV output will remain active after lever/joystick actuation until CU is reset,

# 11 Portable Control Unit self test mode

## 11.1 General description

To simplify service and faultfinding, the portable control unit can be put into internal self test mode. This means that the service man can easily control the Portable Control unit's switches and manoeuvre levers, without the need to open the Portable Control Unit. When each switch or manoeuvre lever is activated / manoeuvred the Portable Control Unit gives a "beep - signal" to confirm that the function is working.

## 11.2 Activating Portable Control Unit Self Test Mode

1. Press the Stop-button on the Portable Control Unit to disable it.
2. Twist up the Stop-button and press On-button once so that the Power-LED is illuminated red.
3. Wait approx. 1 seconds from step 2 then press the On-button in quick successions until the Power-LED is distinguished (approx 10 times).
4. Portable Control Unit Self Test Mode is now active

Each time a switch is activated / manoeuvred the control unit should beep.

Each time a manoeuvre lever is activated / manoeuvred a beep signal should be heard from the Portable Control Unit which increases in "sound intensity" along with lever displacement. The control unit beeps with a continuous tone when the manoeuvre lever is manoeuvred to maximum. This gives a confirmation that the control unit's levers have been manoeuvred fully / max. (If a certain manoeuvre lever does not beep there is a fault in the manoeuvre lever, pin / socket contact or in the control unit's electronic card).

When testing of the Portable Control Unit is completed, press down the Stop-button to exit self test mode.

Note:

When self test mode is active no data is transmitted to the Central Unit.





## 12 ID-code programming

---

### 12.1 General description

The unique ID-code required for radio communication is programmed between the Portable Control Unit and Central Unit

The Central Unit may store the ID-code of maximum one (1) Portable Control Unit, if another Portable Control Unit is required to operate the Central Unit via radio the ID-code procedure is required to be done.

The previous ID-code will be overwritten.

### 12.2 Procedure

1. Remove the battery pack from the Portable Control Unit. Test run the system/application via cable control.
2. Leave the cable control connected between the Portable Control Unit and the Central Unit.
3. Press the Stop-button on the Portable Control Unit and deactivate the Central Unit via the R/M-switch
4. Activate the Central Unit in REMOTE mode, twist up the Stop-button on the Portable Control Unit.
5. Press and hold the On-button on the Portable Control Unit until you get a beep indication (approx 5 seconds). Release the On-button and wait; the Portable Control Unit will beep once followed by the indication "Po-Id" in the LED-display (approx 8 seconds) then further followed by 5 beeps and the deactivate.
6. When ID- programming is completed, remove the cable control, insert battery pack and test run the system/application with radio control.

-If the initial short beep is followed by one long beep, the Central Unit LED-display indication "bL" and Portable Control Unit then deactivates the ID-programming has been rejected, check below for further info.

**Note:**

Via cable control option you can easily determine via the LED-display if the ID-code is accepted; if the LED-display indicates "2-" the ID-code programming procedure is required prior to radio operation, if the LED-display indicates "1-"; the ID-code has already been programmed/accepted.

Typical reasons to ID-programming failure:

The 5th step, pressing and holding the on-button, needs to be initialized from max. 10 seconds from activation of the Central Unit.

The cable control cable is damaged, ensure that no battery is inserted in the Portable Control Unit and that the system/application can be operated via cable alone.

The Portable Control Unit deactivates immediately upon start-up, check that the Power-LED remains lit during the procedure, the Power-LED should remain lit until the last 5 beeps can be heard; if the Portable Control Unit deactivates beforehand it has an internal malfunction.

## 13 G2B Standard Cable Kits

### 13.1 General description

Various standard cable kits exist to suit certain system configurations and valves/coils.

Typically two sets of cable kits are required, one for power supply and digital functions and one for analogue functions, see below illustration.



1 = Left side; "Supply Cable kit" for power supply and digital functions.  
2 = Right side; "Valve Cable kit" for analogue functions.

### 13.2 Standard Supply cable kits

For connection of power supply input, DV-output, Digital functions and CANBUS.

Central Unit type:  
2010  
2011  
3010  
3011

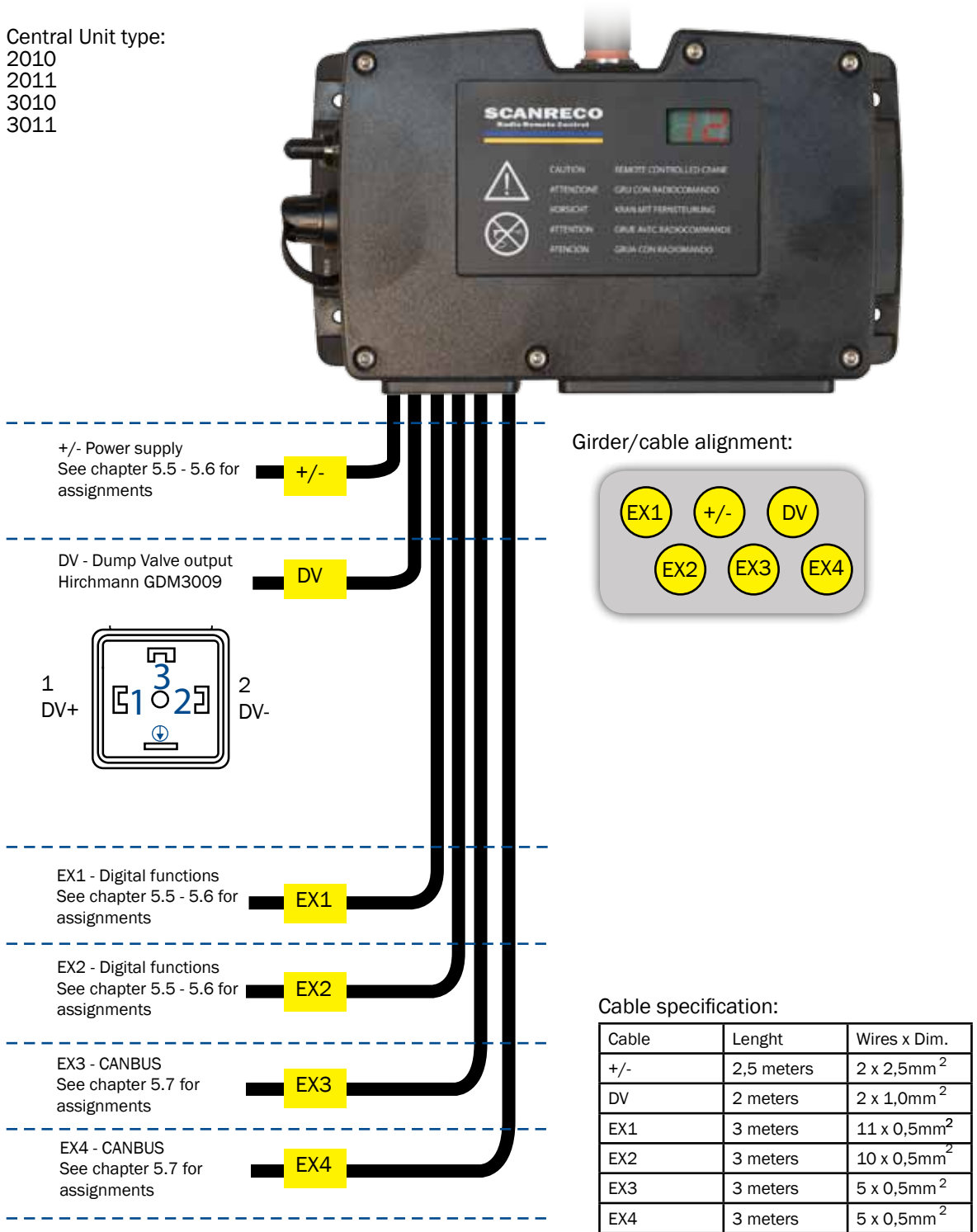

Part number information:

Part no:	Output Cables
47979	Power supply, DV & EX1
47752	Power supply, DV, EX1 & EX2
48810	Power supply, DV, EX1, EX2, EX3 & EX4

### 13.3 Standard valve cable kits for Sauer-Danfoss PVG-32

For connection of analogue functions for Sauer-Danfoss PVG-32 module

Central Unit type:  
2010  
2011



Girder/cable alignment:

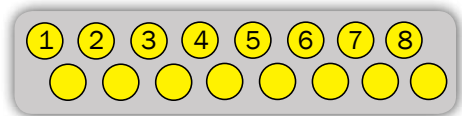

**CONNECTOR:**  
AMP-JPT 4-pol

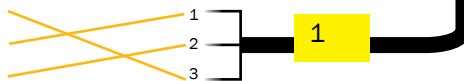
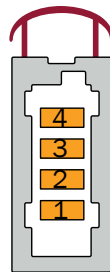

WIRE:  
1 = MODULE SUPPLY  
2 = REGULATED SUPPLY  
3 = GND

**CONNECTOR:**  
Hirschmann GDM3009

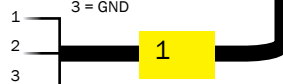
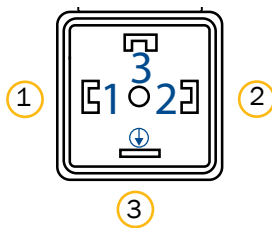

WIRE:  
1 = MODULE SUPPLY  
2 = REGULATED SUPPLY  
3 = GND

Cable specification:

Cable	Length	Wires x Dim.
1-8	2 meters	3 x 0,5mm

Part number information:

Part no:	No of outputs	Type of connector
47753	8	AMP-JTP 4-pol
47961	8	Hirschmann GDM3009

### 13.3 Standard valve cable kits for HAWE

For connection of analogue functions for HAWE module

Central Unit type:  
3010  
3011



Girder/cable alignment:

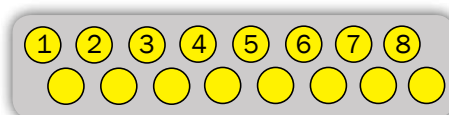

**CONNECTOR:**  
**Hirschmann GDM3009**

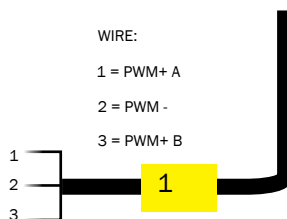
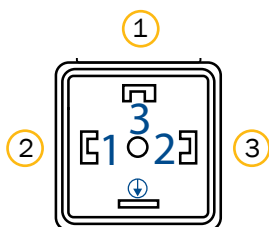

Cable specification:

Cable	Lenght	Wires x Dim.
1-8	2 meters	3 x 0,5mm

Part number information:

Part no:	No of outputs	Type of connector
48046	8	Hirschmann GDM3009

### 13.3 Standard valve cable kits for PWM solenoids

For connection of analogue functions for PWM solenoids

Central Unit type:  
3010  
3011



Girder/cable alignment:

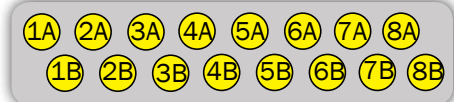

**CONNECTOR:**  
AMP-JPT 2-pol

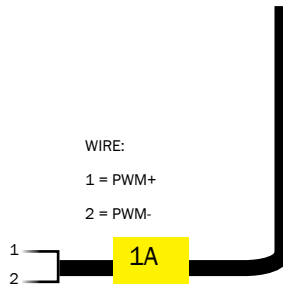
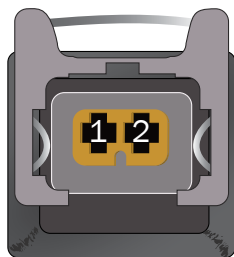

**CONNECTOR:**  
Hirschmann GDM3009

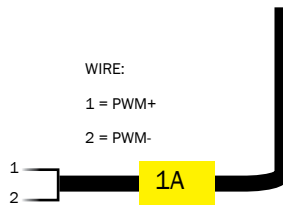
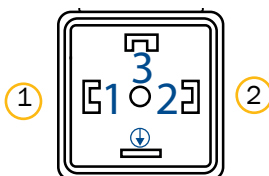

Cable specification:

Cable	Length	Wires x Dim.
1-8 (A/B)	2 meters	2 x 0,5mm

Part number information:

Part no:	No of outputs	Type of connector
47925	8 (1A-4B)	Hirschmann GDM3009
47924	12 (1A-6B)	Hirschmann GDM3009
47903	16 (1A-8B)	Hirschmann GDM3009
48238	12 (1A-6B)	AMP-JPT 2-pol
48362	16 (1A-8B)	AMP-JPT 2-pol



# **SCANRECO**

**Radio Remote Control**