

UK 0.25 - UK 0.5



Coperchio: filetto G1/4 profondità utile 12 mm.

Fissaggio pompa: n. 2 viti M5, coppia di serraggio $5,4 \pm 0,5$ Nm.

Cover: G1/4 thread depth 12 mm.

To mount the pump: n. 2 M5 screws, with a torque wrench setting fixed at 5.4 ± 0.5 Nm.

OPZIONI

"KE": filetto M10x1 profondità utile 9 mm, filetto G1/4 profondità utile 9 mm.

OPTIONS

"KE": M10x1 thread depth 9 mm, G1/4 thread depth 9 mm.

ASPIRAZIONE
INLET

MANDATA
OUTLET

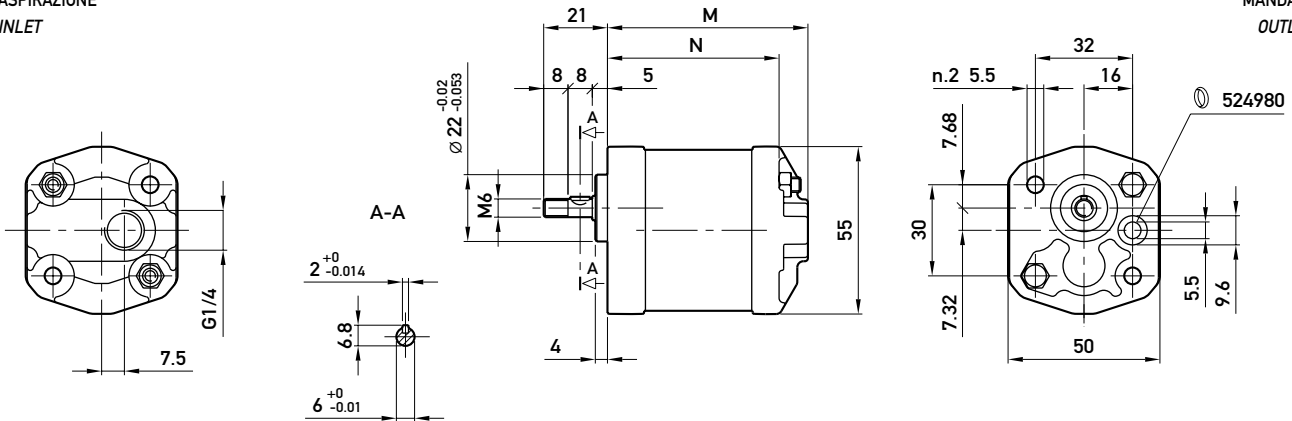

Opzioni:
Options:

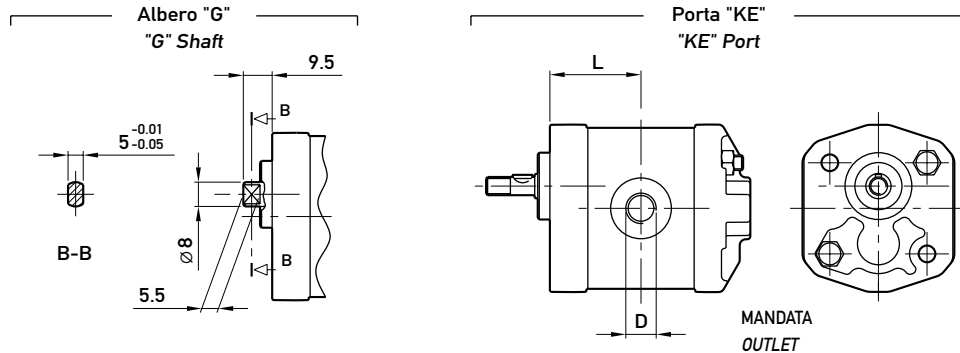

TIPO TYPE	CILINDRATA DISPLACEMENT	PORTATA a 1500 giri/min FLOW at 1500 rev/min	PRESSIONI MASSIME MAX PRESSURE			VELOCITÀ MASSIMA MAX SPEED	DIMENSIONI DIMENSIONS			
			P ₁	P ₂	P ₃		M	N	L	D
	cm ³ /giro (cm ³ /rev)	litri/min (litres/min)	bar	bar	bar	giri/min (rpm)	mm	mm	mm	-
UK 0.25 D 18	0,19	0,29	190	210	230	7000	54	44,5	24	M10x1
UK 0.25 D 24	0,26	0,38	190	210	230	7000	55	45,5	24,5	M10x1
UK 0.25 D 30	0,32	0,48	190	210	230	7000	56	46,5	25	M10x1
UK 0.25 D 36	0,38	0,58	190	210	230	7000	57	47,5	25,5	M10x1
UK 0.25 D 48	0,51	0,77	190	210	230	7000	59	49,5	26,5	M10x1
UK 0.25 D 60	0,64	0,96	190	210	230	7000	61	51,5	27,5	M10x1
UK 0.5 D 0,50	0,50	0,75	190	210	230	7000	63	53,5	28,5	G1/4
UK 0.5 D 0,75	0,63	0,94	190	210	230	7000	64	54,5	29	G1/4
UK 0.5 D 1,00	0,88	1,31	190	210	230	7000	66	56,5	30	G1/4
UK 0.5 D 1,30	1,00	1,50	190	210	230	6000	67	57,5	30,5	G1/4
UK 0.5 D 1,60	1,25	1,88	190	210	230	5000	69	59,5	31,5	G1/4
UK 0.5 D 2,00	1,50	2,25	190	210	230	4000	71	61,5	32,5	G1/4