

VSQ-D-C-...-CC-...

VALVOLA DI SEQUENZA AD AZIONE DIFFERENZIALE E CON COLLETTORE IN LINEA
SEQUENCE VALVE, DIFFERENTIAL AREA PISTON TYPE VALVE WITH IN LINE BODY

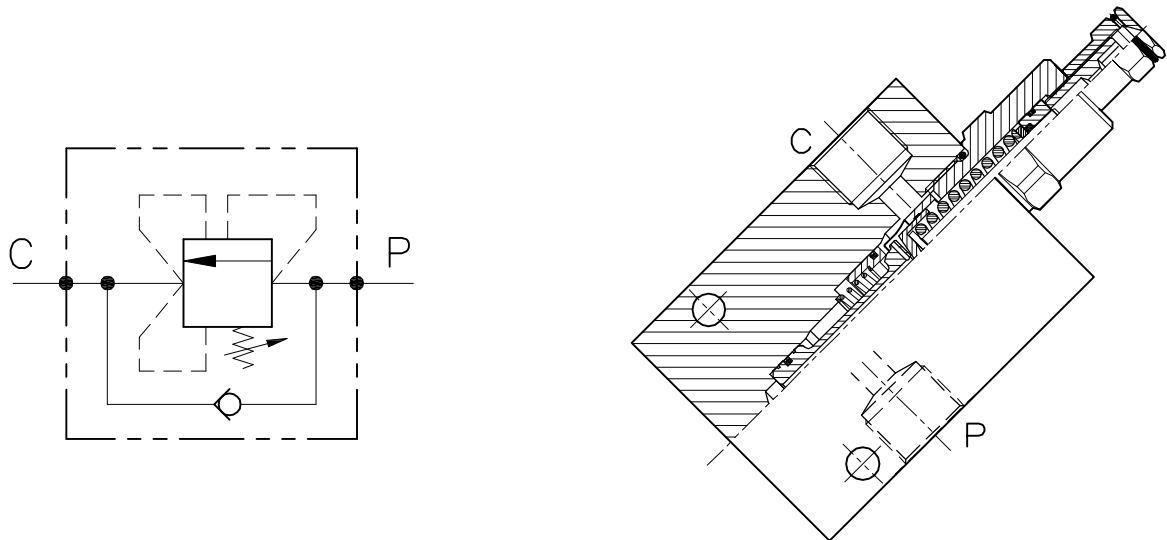

CARATTERISTICHE

Luce nominale min/max	DN 12/14
Portata min/max	1/180 l/min - 0.26/48 GPM
Pressione di lavoro max.	350 bar - 5075 PSI
Pressione max. di taratura	350 bar - 5075 PSI
Temperatura ambiente	-30°C + 50°C
Temperatura olio	-30°C + 80°C
Filtraggio consigliato	30 micron
Peso 3/4" GAS	1.441 Kg
Peso 1" GAS	1.684 Kg

PERFORMANCE

Min/max rated size
Min/max flow-rate
Max working pressure
Max setting pressure
Room temperature
Oil temperature
Recommended filtration
Weight 3/4" GAS
Weight 1" GAS

VSQ-D-C-34-CC e 100-CC

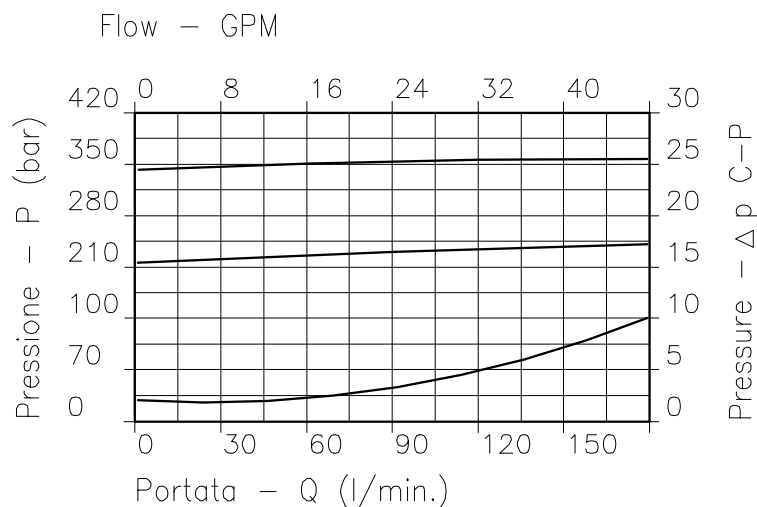

Viscosità olio 46 cSt a 50°C
Oil viscosity 46 cSt at 50°C

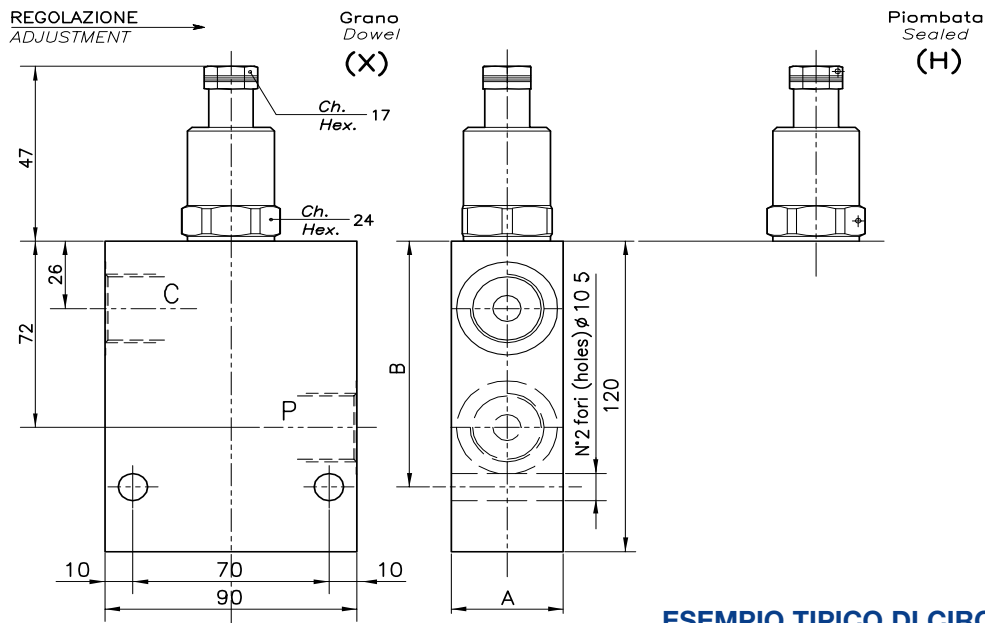

ESEMPIO TIPICO DI CIRCUITO TYPICAL CIRCUIT EXAMPLE

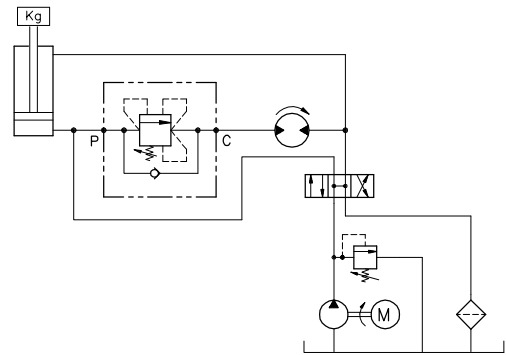

DIMENSIONI DIMENSIONS

Campo taratura Setting range	A	B	Attacchi Port size P-C GAS (BSPP)	Luce nominale Rated size DN	Portata max Max flow-rate l/min - GPM
696	40	95	3/4"	12	150-40
697	50	107	1"	14	180-48

CODICE DI ORDINAZIONE HOW TO ORDER

002 696 0 X 0

Campo taratura / Setting range	
696	
697	
Campo taratura 60÷350 bar (molla colore giallo) Setting range 60÷350 bar (yellow spring)	
Taratura standard (Q=5 l/1')	Incr. press. - bar giro/vite
Std. bar setting (Q=5 l/1')	Pressure rise - turn of screw
350 bar	(--)

Regolazione Adjustment	
X	Grano - Dowel
H	Piombata - Sealed