

SECTION A

INTEGRAL AC MOTORS



Integral motors: these are motors specifically engineered and manufactured for our mini power packs, featuring high power density and direct connection to the PPM.

They are available in single phase or three phase execution, in frame 71 with square flange and tang drive shaft. A single coupling fits all dimensions.

Other powers and/or special designs are available on request. Standard motors are for intermittent use: S3 40% is a typical work cycle consisting of up to six cycles (on-off) in one hour with the motor ON and OFF for 4 min to 6 min. These motors can be used in emergency situations even in continuous use at a reduced power (30% less than the nominal value S3).



Drawings show typical three phase motors. Single phase motors have a larger wiring box which also contains the capacitor(s) or can have an external capacitor(s).

Protection degree: IP54
Insulation class: F
Type of duty: S3= intermittent use

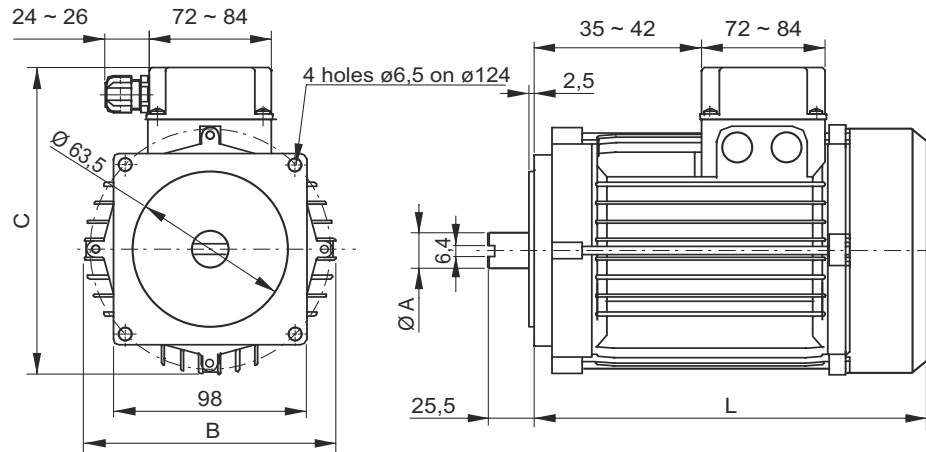

PPM motor assembly code

N	AC integral motor
0,75	Maximum Power [kW]
AC	Alternate current
3	Fasi: 3 = three phase S = single phase
4	Poli: 4 = four poles 2 = two poles
71	Cassa

See a table of available codes on next page

A single coupling will fit all motor frame sizes. This is the same coupling (pump side) included in the B14 motor mounting kit. The coupling is already included when specifying an integral AC motor in the PPM assembly code. When ordering spare motors, the coupling is not included and must be ordered separately.

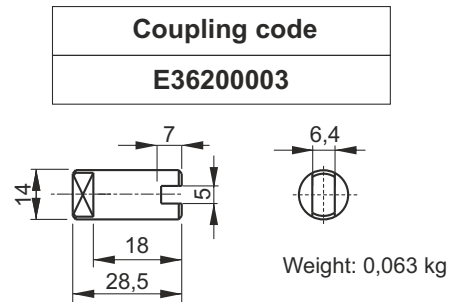

INTEGRAL AC MOTORS

Three-phase 4 poles (~1450 rpm at 50Hz)

Frame size	Maximum Power (S3 40%)	Assembly code	Spare motor code	Ø A	B	C	L	Weight kg
71	0,37kW (0,5HP)	N0,37AC 34 71	N037AC341S3	15	138	180	210	5,5
	0,55kW (0,75HP)	N0,55AC 34 71	N055AC341S3	15	138	180	210	5,5
	0,75kW (1HP)	N0,75AC 34 71	N075AC341S3	15	138	180	210	5,5

Three-phase 2 poles (~2900 rpm at 50Hz)

Frame size	Maximum Power (S3 40%)	Assembly code	Spare motor code	Ø A	B	C	L	Weight kg
71	0,55kW (0,75HP)	N0,55AC 32 71	N055AC321S3	15	138	180	210	5
	0,75kW (1HP)	N0,75AC 32 71	N075AC321S3	15	138	180	210	5

Single-phase 4 poles (~1450 rpm at 50Hz)

Frame size	Maximum Power (S3 40%)	Assembly code	Spare motor code	Ø A	B	C	L	Weight kg
71	0,37kW (0,5HP)	N0,37AC S4 71	N037ACS41S3	15	138	180	210	6,5
	0,55kW (0,75HP)	N0,55AC S4 71	N055ACS41S3	15	138	180	210	7,2

Single-phase 2 poles (~2900 rpm at 50Hz)

Frame size	Maximum Power (S3 40%)	Assembly code	Spare motor code	Ø A	B	C	L	Weight kg
71	0,55kW (0,75HP)	N0,55AC S2 71	N055ACS21S3	15	138	180	210	6
	0,75kW (1HP)	N0,75AC S2 71	N075ACS21S3	15	138	180	210	6,5