

A5000020011 - Max flow = 70 l/min

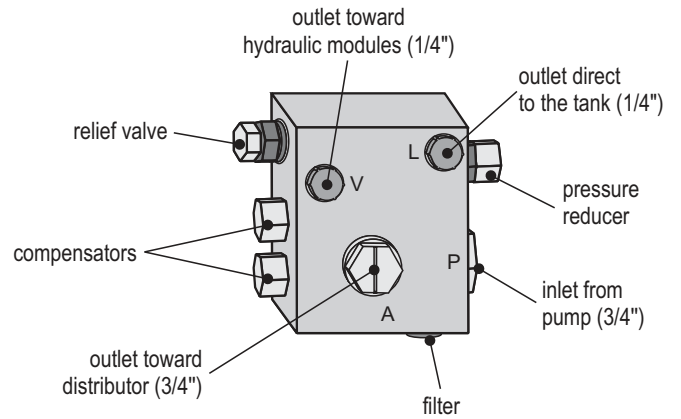

A5000020021 - Max flow = 140 l/min

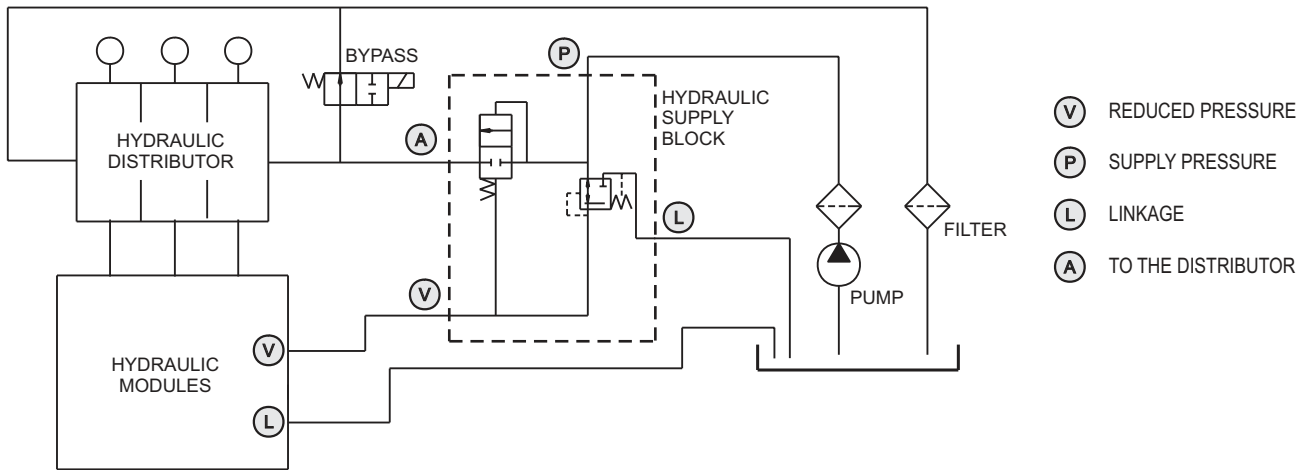

TYPICAL APPLICATION: HYDRAULIC CIRCUIT

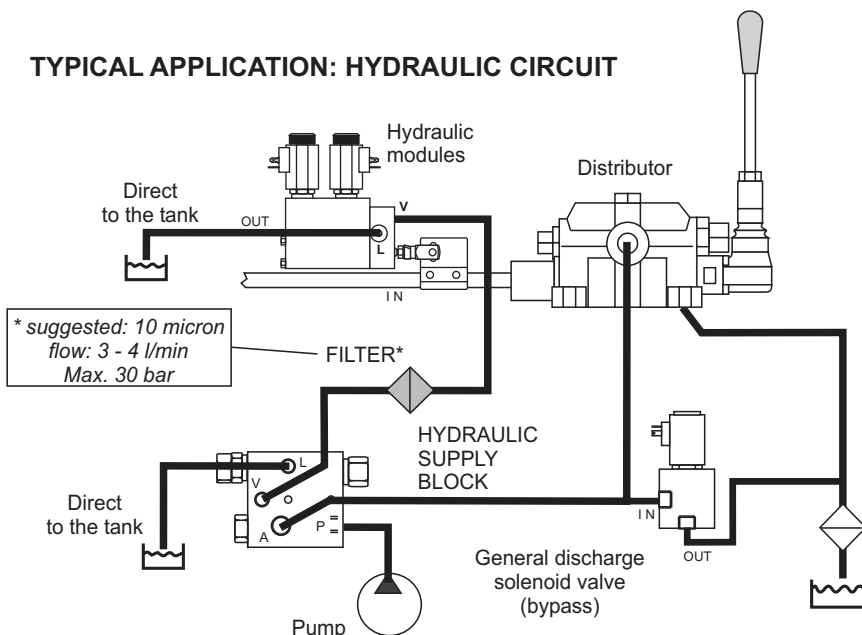

Technical specifications

Max flow	70 l/min (A5000020011) 140 l/min (A5000020021)
Pressure working	210 bar in P 18 + 25 bar in V 1 bar in L
Maximum pressure	350 bar
Default filtering	ISO4406 18/14
Fluid	20-150 cSt
Body material	Aluminium
Weight	70 l/min : 1,2 Kg 140 l/min : 2,3 Kg
Dimensions (mm)	70 l/min: 133x83x50 140 l/min: 148x115x50