

## DOUBLE ACTING STABILIZER CYLINDERS

### HSKPIE-9010

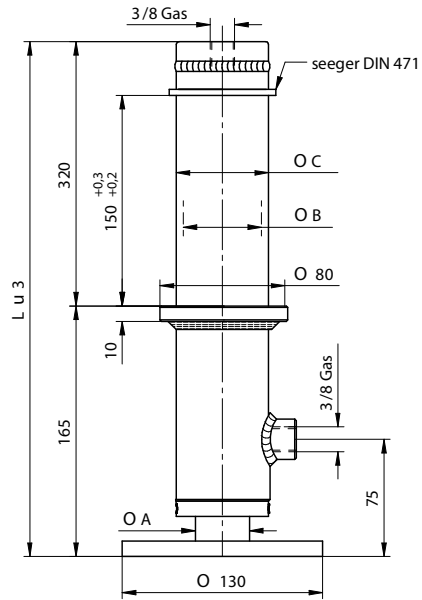

CHROMATE PISTON ROD

### HSKPIE-9012

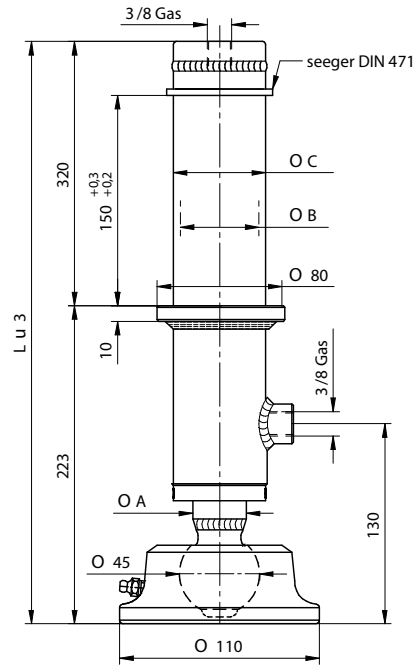

OPTIONAL

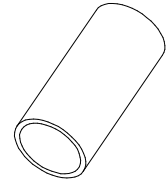

09019

TYPE	DIMENSIONS mm.				STROKE mm.	AMOUNT OIL Lt.	WEIGHT KG.	CAPACITY Kg.	
	ØA	ØB	ØC	L				bar 100	bar 180
HSKPIE-9010	35	50	60	485	325	0,7	7,5	1950	3500
HSKPIE-9012	35	50	60	543	325	0,7	9	1950	3500