

CHECK VALVE

- Max Flow.....**40 l/min**
- Max Pressure.....**350 bar**
- Leakage.....**0,25 cc/min**
- Seals.....**NBR and PTFE**
- Cartridge tightening torque.....**40 Nm**
- Weight.....**0,1 Kg**
- Cavity.....**C220000** page **208**
- Body.....**171202** page **186**

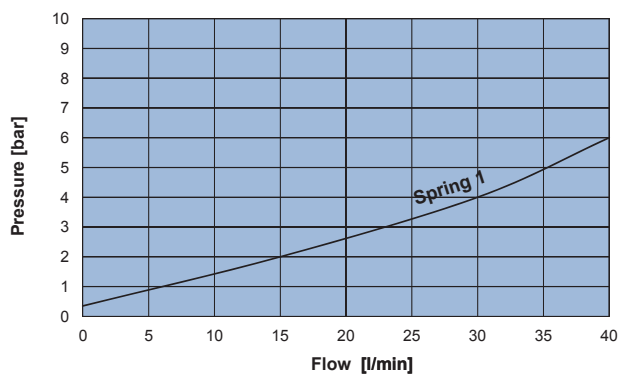
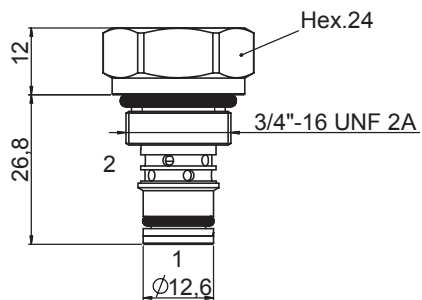

Ordering code

0 7 0 2 1 0 **0 0 0**

SPRINGS	1	2	3
Cracking pressure [bar]	0,35	2,5	5

