

GB**WARRANTY**

Our products are guaranteed for a period of 12 months after the date of delivery. Warranty will not be acknowledged if the products are not used according to the manufacturer's instruction or are badly maintained. Always ask for original Spare-parts, otherwise warranty will not be acknowledged.

F**GARANTIE**

Nos produits sont garantis pour 12 mois à partir de la date de livraison. Aucune garantie ne sera reconnue, suite au mauvais entretien ou emploi anormal des produits. Pour tous vos besoins de pièces de rechange, demandez toujours les rechanges originaux. Au contraire, aucune garantie ne sera reconnue.

D**GARANTIE**

Die Firma gewährt eine Garantie von 12 Monaten, gerechnet vom Lieferdatum. Zweckfremder Einsatz und/oder nachlässige Wartung schließen jede Garantie aus. Im Bedarfsfall immer Original-Ersatzteile von der Firma anfordern. Anderenfalls kann keine Garantie gewährt werden.

E**GARANTÍA**

Nuestros productos están garantizados por 12 meses desde la fecha de la entrega. Ninguna garantía será reconocida por malo mantenimiento o por uso incorrecto de los productos. Pidan siempre repuestos originales. En caso contrario no se reconocerá ninguna garantía.

I**GARANZIA**

I nostri prodotti sono garantiti per mesi 12 dalla consegna. La Ditta si assume la responsabilità per tutti quei particolari che presentassero difetti di materiale o di lavorazione. Non è riconosciuta la garanzia per cattiva manutenzione, anormale impiego e per quelle parti non costruite dalla Ditta. Le riparazioni dovranno essere effettuate presso la fabbrica o da personale autorizzato. Nello stesso istante in cui i prodotti saranno manomessi da terzi, ogni garanzia sarà ritenuta scaduta. Per ogni verifica i prodotti dovranno essere inviati in Porto Franco. Nel caso di effettiva necessità di sostituzione di particolari sarà addebitato il solo costo della mano d'opera. Per il vostro fabbisogno di ricambi chiedete sempre ricambi originali. In caso diverso non sarà riconosciuta alcuna garanzia.





















Numero per ordini telefonici:

(+39) 059.41.4.411

Numero per ordini con fax:

(+39) 059.253.505

**Prescription for Montaggio
Prescription for Assembly**

	Avvitare con Loctite 2701 Frenaflettì FORTE (Verde) Screw down with Loxalel 83-21 STRONG (Green) thread sealer
	Incollare con Biadesivo acrilico VHB-3M 4945 Glue with VHB-3M 4945 acrylic biadhesive
	Sigillare con Arexons MOTORSL D Seal with Arexons MOTORSL D
	Sigillare con Arexons Mastice Seal with Arexons Filler
	Sigillare con Loxalel 59-10 Seal with Loxalel 59-10
	Spruzzare un velo di Molykote D-32 IR Spray Spray on a light coat of Molykote D-32 IR
	Incollare con Loctite 454 Glue with Loctite 454
	Avvitare con Loxalel 24-18 Frenaflettì DEBOLE (Porpora) Screw down with Loxalel 24-18 WEAK (Purple) thread sealer
	Avvitare con Loxalel 55-14 Frenaflettì MEDIO (Rosso) Screw down with Loxalel 55-14 MEDIUM (Red) thread sealer
	Avvitare con Loxalel 83-21 Frenaflettì FORTE (Verde) Screw down with Loxalel 83-21 STRONG (Green) thread sealer
	Montare a caldo con RISCALDATORE Assemble hot with HEATER
	Montare con PRESSA Assemble with PRES
	Lubrificare con GRASSO MINERALE Lubricate with MINERAL GREASE
	Lubrificare con OLIO MOTORE Lubricate with ENGINE OIL
	Coppia serraggio Tolleranza +0/-10% Nm Tightening torque tolerance +0/-10% Nm
	Lubrificare con GRASSO P40 Lubricate with P40 GREASE
	Lubrificare con GRASSO Molykote 1000 Lubricate with Molykote 1000 GREASE
	Lubrificare con GRASSO Molykote PG54 Lubricate with Molykote PG54 GREASE
	Avvitare con Loctite 5331 (Bianca) Screw down with Loctite 5331 (White)
	Lubrificare con GRASSO Molykote GB07 Lubricate with Molykote GB07 GREASE

Characteristics and descriptions are not binding. - Données descriptives et illustrations n'engagement pas le constructeur. - Angaben, Beschreibungen, und Illustrationen sind nicht verbindlich. - Notas y ilustraciones no son empesativas. - Os dados, descrições e ilustrações são fornecidos a título informativo e não comprometem o fabricante. - Dati, descrizioni ed illustrazioni sono forniti a titolo indicativo e non impegnativo.



ATTENTION: This manual must be read before beginning installation of the unit.
ATTENTION: Ce livret doit être lu avant d'installer et d'employer le produit.
ACHTUNG: Das vorliegende Handbuch ist vor der Installation und dem Gebrauch des Produkts aufmerksam zu lesen.
ATENCIÓN: Este manual debe ser leído antes de proceder a la instalación y uso de producto.
ATENÇÃO: Este manual deve ser lido antes de proceder à instalação e ao uso do produto.
ATTENZIONE: Il presente libretto va letto prima di procedere all'installazione ed uso del prodotto.

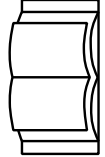

ANNOVI REVERBERI
The Power of Experience

ANNOVI REVERBERI S.p.A.

Via M.L. King, 3 - 41122 Modena (Italy)
Tel. (+39) 059.414.411 - Telefax (+39) 059.253.505
E-Mail Italia: agricoltura.it@annovireverberi.it
E-Mail export: agriculture.export@annovireverberi.it

Member of



- Control units for medium and high pressure pumps - Grupo de mando para bombas de media y alta presión
- Groupes de commande pour pompes moyennes et haute pression - Gruppi comando per pompe a media ed alta pressione

- Bedienungsarmaturen für Mittel- und Hochdruckpumpen

BY MATIC 50

TECHNICAL DATA / DONNÉES TECHNIQUES / TECHNISCHE ANGABEN
CARACTERÍSTICAS TÉCNICAS / CARATTERISTICHE TECNICHE

CONTROL UNITS GROUPES DE COMMANDE BEDIENUNGSARMATUREN GRUPOS DE MANDO GRUPPI COMANDO	OUTPUT DEBIT LEISTUNG CAUDAL PORTATA		PRESSURE PRESSION DRUCK PRESSIONE		N. VALVES N. ROBINETS N. VENTILEN N. ROBINETS N. RUBINETTI	WEIGHT POIDS GEWICHT PESO PESO
	l/min	gpm (US)	bar	psi		
BY MATIC 50	200	52,8	50	725	2 (+2)	kg 2,7

cod. 99370-FR

BY MATIC 50 cod. 960 - cod.905 (con manometro ISOMETRICO)

1156010

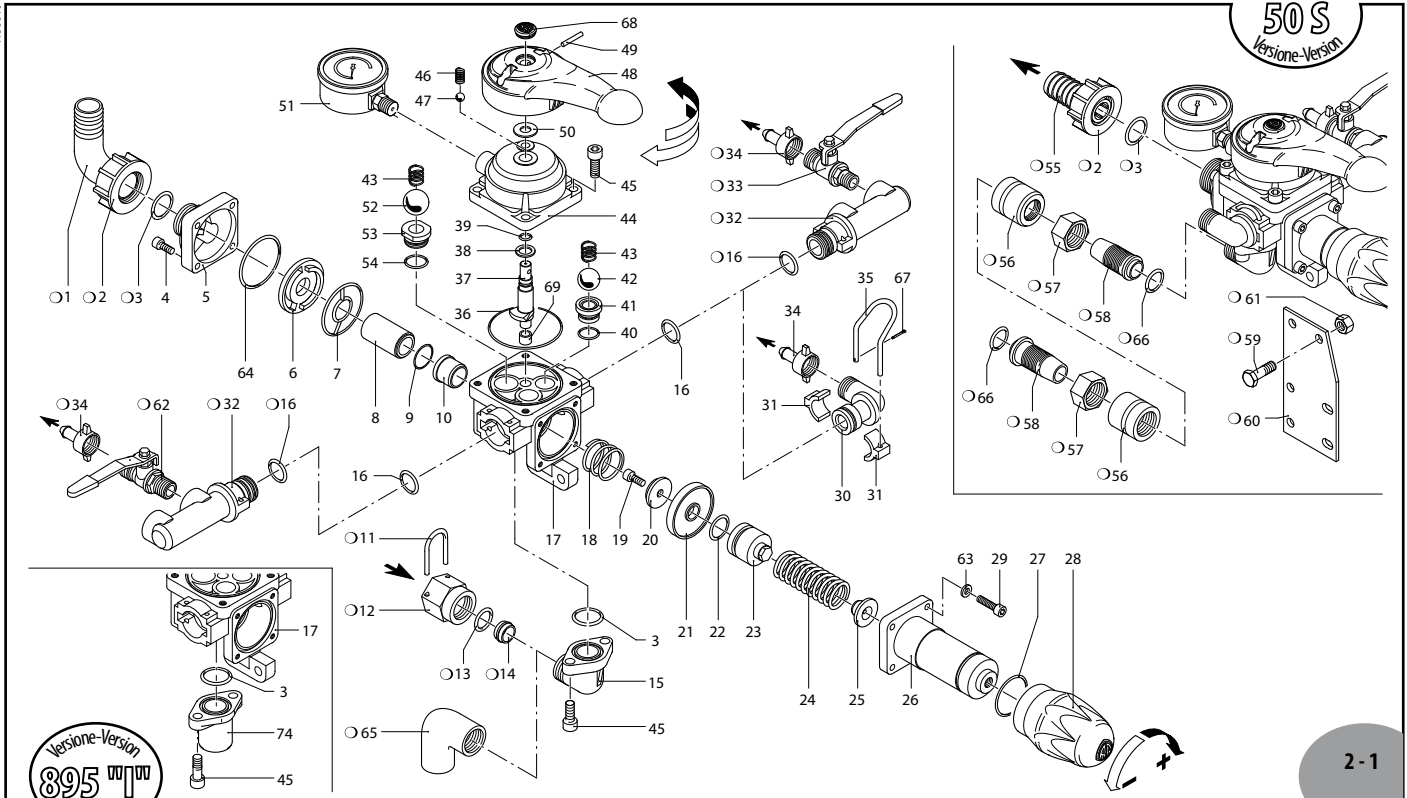

SL000308-BU

Pos	Cod.	Descrizione	Description	Q.ty	Note
1	550370	Curva Ø 25	Elbow	1	
2	550242	Girello 1" G	Ring nut	1	
3	550350	Guarnizione OR Ø 23,81x2,62	O-ring	2	☒
4	780060	Vite TCEI M6x25	Screw	4	C ₀
5	1150031	Flangia	Flange	1	
6	1150021	Disco	Plate	1	
7	1150041	Guarnizione	Gasket	1	▶
8	1150050	Distanziale	Spacer	1	
9	770590	Guarnizione OR Ø 21,95x1,78	O-ring	1	▶
10	1150060	Sede	Seat	1	
11	850760	Forcella	Fork	1	
12	850750	Ghiera 3/4" G F	Ring nut	1	
13	390180	Guarnizione OR Ø 18,72x2,62	O-ring	1	▶
14	850490	Anello	Ring	1	
15	850713	Raccordo 1/2" G M	Fitting	1	
16	390060	Guarnizione OR Ø 20,63x2,62	O-ring	4	▶
17	1150012	Corpo	Body	1	
18	320420	Molla	Spring	1	☒
19	680700	Vite TCEI M6x20	Screw	1	☒ C ₀ Inox
20	1150070	Valvola	Valve	1	
21	1150130	Membrana	Diaphragm	1	Desmopan ☒
22	1150131	Membrana	Diaphragm	1	NBR
23	620031	Guarnizione OR Ø 25,80x3,53	O-ring	1	▶ Viton
24	1150180	Pistone	Piston	1	
25	1150190	Molla	Spring	1	☒
26	1150200	Piattello	Wobble plate	1	
27	1150171	Corpo guida molla	Body	1	
28	820490	Guarnizione OR Ø 34,65x1,78	O-ring	1	▶
29	1150921	Manopola	Knob	1	Nera
30	1040370	Vite TCEI M6x22	Screw	4	C ₀
31	1150140	Raccordo	Fitting	2	
32	1150150	Morsetto	Clamp	4	
33	1150161	Corpo rubinetto	Body	2	
34	160142	Rubinetto 1/2" G M-M SX	Cock	2	☒
35	110130	Girello 1/2"	Ring nut	4	
36	1040690	Forcella	Fork	2	
37	1150251	Guarnizione OR Ø 65x2	O-ring	1	▶ Viton
38	1150120	Perno	Hub pin	1	
39	850720	Rondella	Washer	1	▶
40	390340	Guarnizione OR Ø 7,30x2,4	O-ring	1	▶
41	740290	Guarnizione OR Ø 14x1,78	O-ring	2	▶
42	850650	Sede	Seat	2	
43	850660	Sfera	Ball	2	Inox
44	850680	Molla	Spring	3	☒

sp_bymatic50.pdf

Pos	Cod.	Descrizione	Description	Q.ty	Note
44	1150082	Corpo superiore distributore	Body	1	
45	320360	Vite TCEI M8x22	Screw	6	C ₂₀
46	850830	Molla	Spring	1	☒
47	621160	Sfera	Ball	1	
48	1150891	Leva	Lever	1	Nera
49	1040820	Spina	Pin	1	
50	391460	Rondella	Washer	1	
51	550545	Manometro	Pressure gauge	1	0-80 bar ☒
51	1151010	Manometro isometrico Ø63	Pressure gauge	1	0-50-80 bar ☒
52	1150100	Sfera	Ball	1	Inox
53	1150091	Sede	Seat	1	
54	880270	Guarnizione OR Ø 17,17x1,78	O-ring	1	▶
55	550210	Tubo Ø 25	Pipe	1	
56	850770	Ghiera	Ring nut	2	
57	850790	Girello 3/4" G	Ring nut	2	
58	850780	Portagomma	Hose tail	2	
59	180370	Vite TE M8x25	Screw	2	C ₂₀
60	850690	Staffa	Bracket	1	
61	390270	Dado M8	Nut	2	
62	160141	Rubinetto 1/2" G M-M DX	Cock	2	
63	550331	Rondella	Washer	4	
64	1150280	Guarnizione OR Ø 50,52x1,78	O-ring	1	▶
65	1150690	Raccordo 3/4" G F-F	Fitting	1	
66	960160	Guarnizione OR Ø 17,86x2,62	O-ring	2	▶
67	1040950	Copiglia	Split pin	2	
68	1150930	Tappo	Plug	1	
69	1150840	Boccola	Bushing	1	
74	550394	Flangia	Flange	1	

o Non compreso nel BY MATIC 50 - No part of BY MATIC 50

KIT 1967

OR - O-Rings

Pos.	Q.ty	Pos.	Q.ty
3	2	54	1
9	1		
13	3		
22	1		
27	1		
36	1		
39	1		
40	2		

KIT 1968

Pronto intervento - Maintenance repair

Pos.	Q.ty	Pos.	Q.ty
3	2	21	1
7	1	22	1
9	1	23	1
10	1	24	1
16	2	27	1
18	1	36	1
19	1	38-39	1
20	1	64	1

(1301) (101.07.10 GO)

BY MATIC 50 cod. 960 - cod.905 (con manometro ISOMETRICO)

Kit per/for BY MATIC 50

KIT 895 "I"

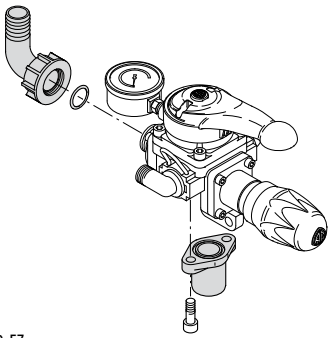

SL000070-EZ

KIT 988 "S"

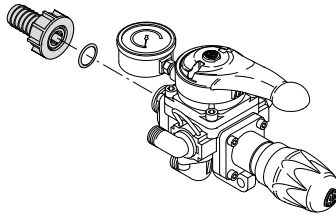

UN000511-IB

KIT 999 "S"

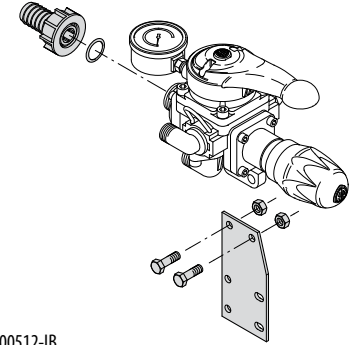

UN000512-IB

KIT 990 "S"

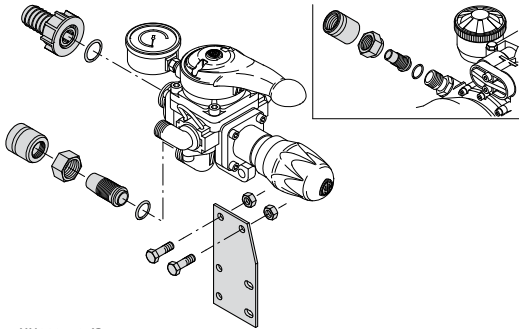

UN000513-IB

KIT 997 "S"

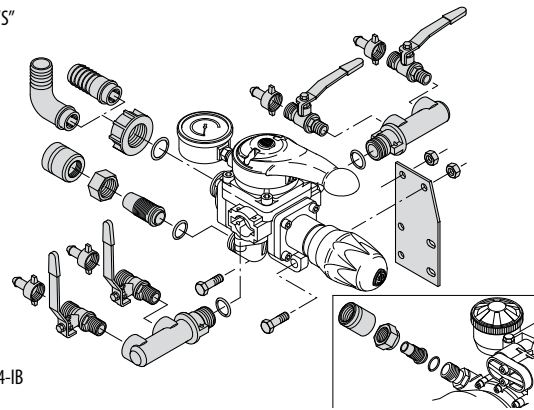

UN000514-IB

Comando incorporato e separato - Build-in control unit and remote control

KIT 895 "I"

Comando incorporato
Build in control

Pos.	Q.ty	Pos.	Q.ty
1	1		
2	1		
3	1		
74	1		

Per / for AR 903 - AR 1053 - AR 1203
BHA/BHP 130 - 150 - 170 - 200
BHS 90 - 105 - 120 - 130 - 150 - 170 - 200

KIT 988 "S"

Comando separato
Remote control

Pos.	Q.ty	Pos.	Q.ty
2	1		
3	1		
55	1		

Per / for AR 713 - AR 813 - AR 1064 - AR 1516
AR 903 - AR 1053 - AR 1203
BHA/BHP 130 - 150 - 170 - 200

KIT 999 "S"

Comando separato
Remote control

Pos.	Q.ty	Pos.	Q.ty
2	1		
3	1		
55	1		
59	2		
60	1		
61	2		

Per / for AR 713 - AR 813 - AR 1064
AR 903 - AR 1053 - AR 1203
BHS/BHA/BHP 130 - 150 - 170 - 200

KIT 990 "S"

Comando separato
Remote control

Pos.	Q.ty	Pos.	Q.ty
2	1	59	2
3	1	60	1
55	1	61	2
56	2	66	2
57	2		
58	2		

Per / for AR 713 - AR 813 - AR 1064
AR 903 - AR 1053 - AR 1203
BHS/BHA/BHP 130 - 150 - 170 - 200

KIT 997 "S"

Comando separato
Remote control

Pos.	Q.ty	Pos.	Q.ty
1	1	57	2
2	1	58	2
3	1	59	2
16	2	60	1
32	2	61	2
33	2	62	2
34	4	66	2
55	1		
56	2		

Per / for AR 713 - AR 813 - AR 1064
AR 903 - AR 1053 - AR 1203
BHS/BHA/BHP 130 - 150 - 170 - 200

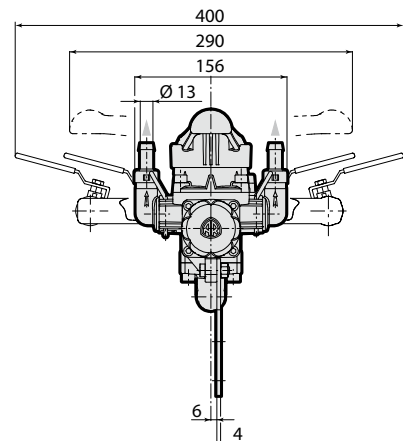
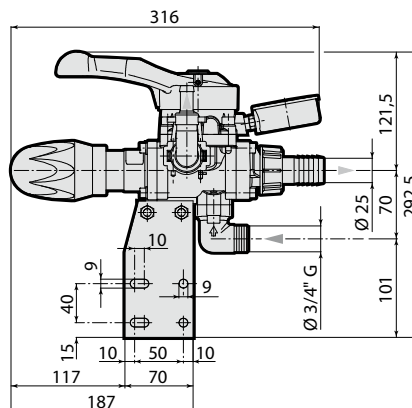

DESCRIPTION AND USE

The BY MATIC 50 control unit is designed for regulating working pressure in the distribution of sprayed liquids.

Numbers refer to the exploded view of the unit. BY MATIC 50 comprises a pressure regulating diaphragm valve with a manual adjustment knob (28). The main body is also equipped with a rapid drain valve. The pressurised outlet is connected to the users through two 1-way manifolds, which can be supplied in 2-way versions on request to provide a total of 4 pressure lines.

ASSEMBLY

1. Firmly secure the mounting bracket (60).
2. Connect the quick couplings to the high pressure line from the pump and then connect BY MATIC 50 to the pump outlet.
3. Connect the drain (55) to the tank directly, without flow restriction elements.
4. Connect the high pressure hoses to the outlet valves.

USE

1. Refer to the pump user handbook.
2. Check for possible leaks in the hydraulic circuit from connections and unions by circulating water through the system.
3. All operations are controlled by a lever (48), the functions of which are illustrated in the following diagram.
4. Use knob (28) to regulate working pressure. Turn clockwise to increase pressure (+), counter clockwise to decrease (-).
5. Flush the control unit with water when you finish work to remove any internal deposits of aggressive products.

DESCRIPTION ET MODE D'UTILISATION

L'unité de commande BY MATIC 50 règle la pression d'utilisation dans la distribution du liquide d'érosage.

Les chiffres rappelés dans le texte correspondent aux repères sur l'étaté. BY MATIC 50 est constituée d'un régulateur de pression à membrane à tarage manuel par la poignée (28). Dans le corps principal du régulateur est incorporé un clapet de décharge rapide. La sortie sous pression vers les utilisations est canalisée par deux collecteurs à 1 voie et, sur demande, à 2 voies pour un total de 4 voies.

MONTAGE

1. Monter solidement la bride (60).
2. Assembler les raccords rapides au tube HP de raccordement avec la pompe, puis brancher BY MATIC 50 au refoulement de la pompe.
3. Raccorder le retour (55) directement à la citerne, sans étranglements.
4. Raccorder les tuyaux HP aux robinets en sortie.

MODE D'UTILISATION

1. Suivre les instructions de fonctionnement de la pompe.
2. Contrôler les fuites éventuelles du circuit hydraulique à la hauteur des jonctions et des raccords, en faisant circuler de l'eau.
3. Toutes les opérations sont commandées par le levier (48) dont les fonctions sont représentées sur le schéma ci-dessous.
4. La poignée (28) règle la pression d'utilisation : une rotation dans le sens des aiguilles d'une montre augmente la pression (+), une rotation dans le sens contraire diminue la pression (-).
5. Laver l'unité de commande entièrement à l'eau après le travail. Veiller à éliminer toute stagnation des produits agressifs.

BESCHREIBUNG UND GEBRAUCH

Das Steueraggregat BY MATIC 50 dient zur Einstellung des Betriebsdruckes bei der Verteilung des Spüthmitteldrucks. Die in Klammern angegebenen Zahlen beziehen sich auf die Explosionszeichnung des Produkts. BY MATIC 50 besteht aus einem Membran-Druckregelventil, das sich durch den Handgriff (28) manuell einstellen läßt. Im gleichen Hauptkörper ist das Schnellablaßventil eingebaut. Die Druckweiterführung zu den Verbrauchern erfolgt über zwei 1-Weg- auf Wunsch 2-Weg Sammelleitungen, insgesamt über 4 Wege.

MONTAGE

1. Den Bügel (60) fest anbringen.
2. Die Schnellanschlüsse an die Hochdruckleitung zum Pumpenanschluß anbringen, danach BY MATIC 50 druckseitig an die Pumpe anschließen.
3. Die Abblöhdleitung (55) direkt, ohne Drosselstellen, an den Tank anschließen.
4. Die Hochdruckleitungen an die Abblöhdventile anschließen.

GEBRAUCH

1. Siehe Betriebsanleitung der Pumpe.
2. Durch Wasserkirkulation überprüfen, ob im Hydraulikkreis an den Anschlüssen bzw. Verbindungen Leckstellen bemerkbar sind.
3. Sämtliche Betätigungen werden durch den Hebel (48) gesteuert, dessen Funktionen im u.a. Schema dargestellt sind.
4. Durch den Handgriff (28) läßt sich der Betriebsdruck einstellen. Beim Drehen im Uhrzeigersinn wird der Druck erhöht (+), beim Drehen gegen den Uhrzeigersinn verringert (-).
5. Nach dem Betrieb ist das Steueraggregat mit Wasser auszuspülen, um Rückstände aggressiver Produkte zu entfernen.

DESCRIPCION Y MODO DE USO

El grupo de mando BY MATIC 50 sirve para regular la presión de trabajo en la distribución de líquido para pulverización.

Las indicaciones numéricas se refieren al gráfico de despiece del producto. BY MATIC 50 está compuesto por una válvula de regulación de la presión a membrana, que se calbra manualmente con la perilla (28). En el cuerpo principal hay una válvula de descarga rápida. La salida a presión está canalizada por dos colectores de 1 vía, a pedido se suministran colectores de 2 vías para un total de 4 vías.

MONTAJE

1. Montar el soporte firmemente (60).
2. Ensamblar los rápidos al tubo de alta presión de conexión con la bomba y, luego, conectar BY MATIC 50 al conducto de impulsión de la bomba.
3. Conectar directamente la descarga (55) a la cisterna, sin producir obstrucciones.
4. Conectar los tubos de alta presión a los grifos en salida.

MODO DE USO

1. Remítirse a las instrucciones operativas de la bomba.
2. Controlar, haciendo circular el agua, que no haya pérdidas ni en las juntas y ni en los rápidos del circuito hidráulico.
3. Todas las operaciones se mandan mediante la palanca (48), cuyas funciones están representadas en el esquema ilustrado más adelante.
4. Mediante la perilla (28) se regula la presión de trabajo: girándola en el sentido de las manecillas del reloj, aumenta la presión (+), y en sentido contrario al de las manecillas del reloj, disminuye (-).
5. Después del trabajo, lavar internamente con agua el grupo de mando y quitar eventuales restos de productos agresivos.

DESCRIZIONE E MODO D'USO

Il gruppo comando BY MATIC 50 serve per la regolazione della pressione di lavoro nella distribuzione del liquido per irrorazione.

I richiami numerici fanno riferimento al disegno esplosivo del prodotto. BY MATIC 50 è composto da una valvola di regolazione della pressione a membrana, tarabile manualmente attraverso la manopola (28). Nello stesso corpo principale vi è inserita la valvola di scarico rapida. L'uscita in pressione agli utilizzatori è canalizzata da due collettori a 1 via, a richiesta a 2 vie per un totale di 4 vie.

MONTAGGIO

1. Montare saldamente la staffa (60).
2. Assemblare i raccordi rapidi al tubo alta pressione di collegamento con la pompa, quindi collegare BY MATIC 50 alla mandata della pompa.
3. Collegare lo scarico (55) alla sistema, senza strozzature direttamente.
4. Collegare i tubi alta pressione ai rubinetti in uscita.

MODALITÀ D'USO

1. Fare riferimento alle istruzioni operative della pompa.
2. Controllare facendo circolare acqua, eventuali perdite del circuito idraulico nelle giunzioni e nei raccordi.
3. Tutte le operazioni sono comandate dalla leva (48) le cui funzioni sono rappresentate nello schema sotto riportato.
4. Mediante la manopola (28) si regola la pressione di lavoro: in senso orario aumenta la pressione (+), in senso antiorario diminuisce (-).
5. Lavare il gruppo comando internamente con acqua dopo il lavoro, togliendo eventuali ristagni di prodotti aggressivi.

ISTRUZIONI PER LA SICUREZZA

- È necessario conservare con cura il presente manuale, leggerlo e rispettare le seguenti istruzioni per la sicurezza:
- Non utilizzare il prodotto con fluidi infiammabili o aventi caratteristiche non compatibili con il corretto funzionamento del prodotto stesso.
 - L'installazione del prodotto deve essere effettuata da personale qualificato.

**SAFETY INSTRUCTIONS**

This manual must be stored carefully. Read and follow the following safety instructions:

- Do not use the unit with flammable liquids, or liquids with characteristics not compatible with the correct functioning of the unit.
- The installation of the unit must be carried out by qualified staff.

**INSTRUCTIONS DE SÉCURITÉ**

Conservé ce manuel avec le plus grand soin. Lire et respecter les instructions de sécurité ci-dessous:

- Ne pas utiliser le produit avec des fluides inflammables ou ayant des caractéristiques incompatibles avec le fonctionnement correct du produit lui-même.
- L'installation du produit doit être effectuée par un personnel qualifié.

**SICHERHEITSAUWEISUNGEN**

Vorliegendes Handbuch sorgfältig aufbewahren und folgende Sicherheitsanleitungen aufmerksam lesen und beachten:

- Produkt nicht mit entzündbaren oder sonstigen Flüssigkeiten verwenden, deren Eigenschaften mit einem einwandfreien Betrieb des Produkts nicht vereinbar sind.
- Die Produktinstallation ist von qualifiziertem Fachpersonal vorzunehmen.

**ISTRUCCIONES PARA LA SEGURIDAD**

Es necesario conservar con cuidado el presente manual, leer y respetar las siguientes instrucciones para la seguridad:

- No utilizar el producto con fluidos inflamables o que tengan características no compatibles con el correcto funcionamiento del producto.
- La instalación del producto debe ser efectuada por personal especializado.

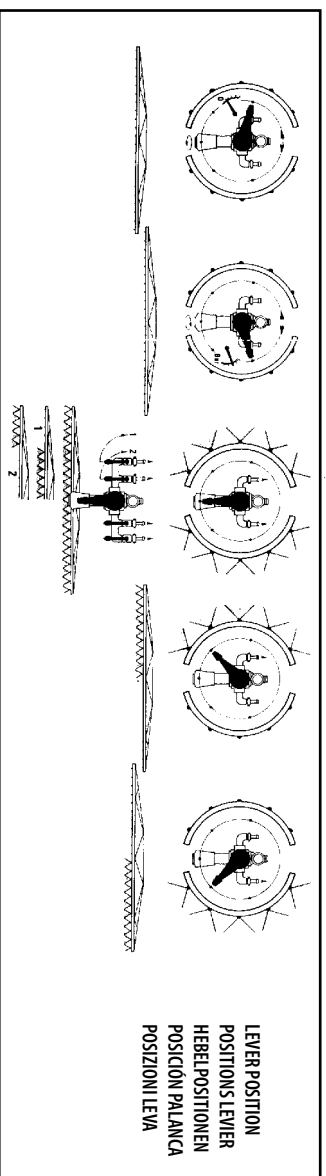

LEVER POSITION
POSITIONS LEVIER
HEBELPOSITIONEN
POSIZIONI PALANCA