

SERIE: 60000

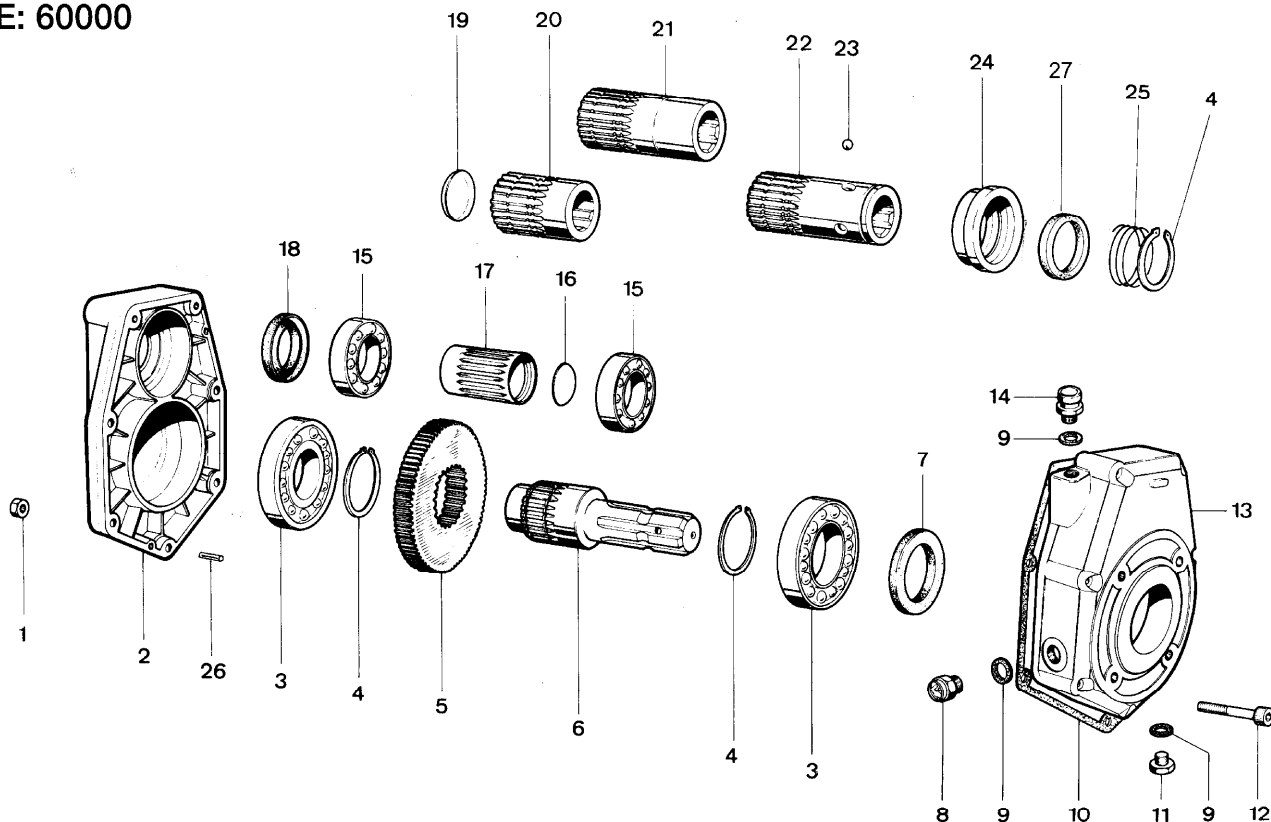

POS.	DENOMINAZIONE	DENOMINATION	DESCRIPTION	BEZEICHNUNG	Q.TÀ
1	Dado M6	Ecrou M6	Nut M6	Mutter M6	8
2	Coperchio	Couvercle	Cover	Dekel	1
3	Cuscinetto tipo 6010	Palier 6010	Bearing type 6010	Kugellager, Type 6010	2
4	Seeger Ø 50	Circlip Ø 50	Snap ring dia. 50	Seegerring, Durchm. 50	3
5	Corona	Couronne	Ring gear	Zahnkranz	1
6	Albero presa di forza maschio 1 3/8"	Arbre prise de force mâle 1" 3/8	Male P.T.O. shaft 1" 3/8	Antriebswelle mit Aussenverkeilung 1 3/8"	1
7	Anello di tenuta Ø 50x65x8	Bague d'étanchéité 50x65x8	Sealing ring Ø 50x65x8	Dichtring, Durchm. 50x65x8	1
8	Tappo livello olio 3/8"	Bouchon niveau huile 3/8"	Oil level plug 3/8"	Ölstandschraube 3/8"	1
9	Guarnizione	Joint	Gasket	Dichtung	3
10	Guarnizione	Joint	Gasket	Dichtung	1
11	Tappo scarico olio 3/8"	Bouchon vidange huile 3/8"	Oil drain plug 3/8"	Ölablaßschraube 3/8"	1
12	Vite T.C.E.I. M6x50	Vis T.C.H.C. M6x50	Socket capscrew M6x50	Zylinderkopfschraube mit Innensechskant M6x50	8
13	Scatola	Carcasse	Housing	Gehäuse	1
14	Tappo sfiato olio 3/8"	Bouchon reniflard huile 3/8"	Oil breather plug 3/8"	Entlüftungsschraube 3/8"	1
15	Cuscinetto tipo 6007	Palier 6007	Bearing type 6007	Kugellager, Type 6007	2
16	Coperchietto DIN 470 - Ø 27	Petit couvercle DIN 470 D. 27	Cap DIN 470 Ø 27	Deckel DIN 470, Durchm. 27	1
17	Pignone	Pignon	Pinion Gear	Ritzel	1
18	Anello di tenuta Ø 35x52x7	Bague étanchéité 35x52x7	Sealing ring Ø 35x52x7	Dichtring, Durchm. 35x52x7	1
19	Coperchietto DIN 470 - Ø 40	Petit couvercle DIN 470 D. 40	Cap DIN 470 Ø 40	Deckel DIN 470, Durchm. 40	1
20	Albero presa di forza femmina 1 3/8" corto	Arbre prise de force femelle 1" 3/8 court	Female P.T.O. shaft 1" 3/8 short	Antriebswelle mit Innenverkeilung 1 3/8", kurz	1
21	Albero presa di forza femmina 1 3/8" lungo	Arbre prise de force femelle 1" 3/8 long	Female P.T.O. shaft 1" 3/8 long	Antriebswelle mit Innenverkeilung 1 3/8", lang	1
22	Albero presa di forza femmina 1 3/8" attacco rapido	Arbre prise de force femelle 1" 3/8 attelage rapide	Female P.T.O. shaft 1" 3/8 quick fitting	Antriebswelle mit Innenverkeilung 1 3/8", mit Schnellkupplung	1
23	Sfera	Bille	Ball	Kugel.	3
24	Anello porta molla	Bague porte-ressort	Spring ring	Federhaltering	1
25	Molla	Ressort	Spring	Feder	1
26	Spina 5x16	Goupille 5x16	Peg 5x16	Stift, Durchm. 5x16	2
27	Anello	Bague	Ring	Ring	1

SERIE: 60000

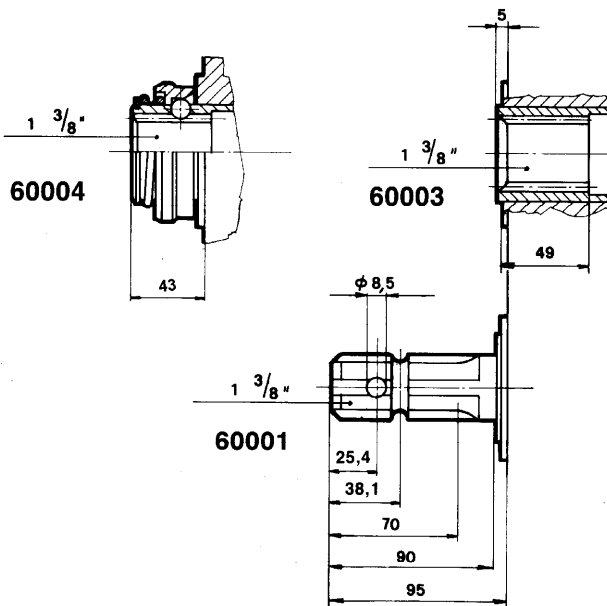
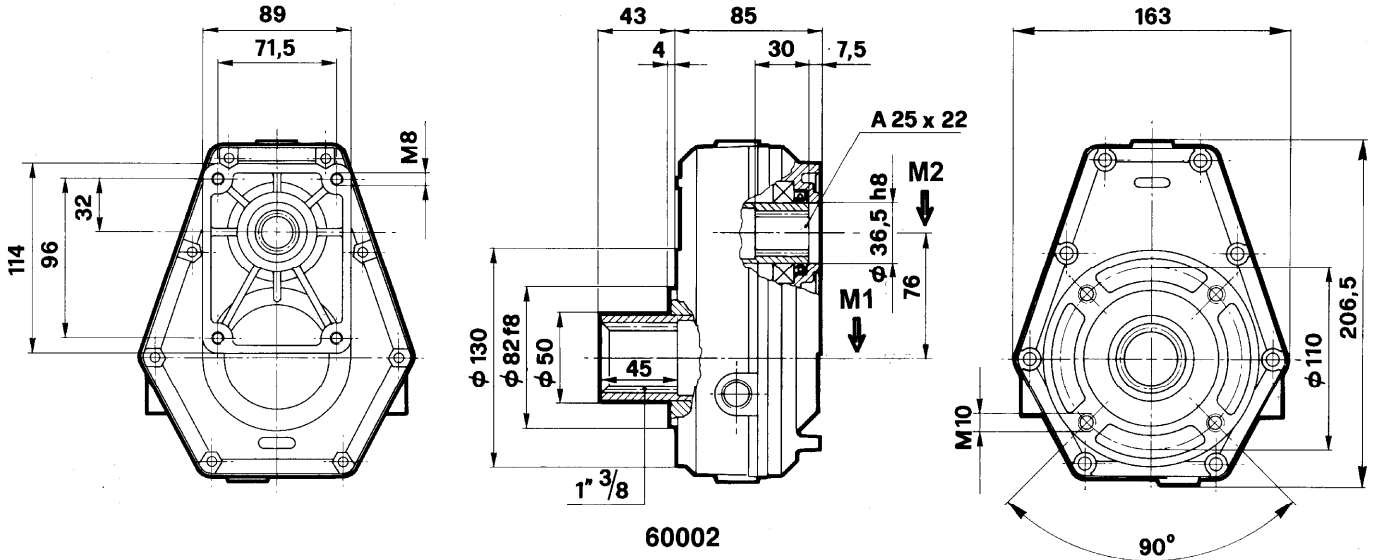

Livello max olio: Lt. 0,220

M1	M2	N. 1 GIRI/1' TOURS/1' R.P.M. U/min	N. 2 GIRI/1' TOURS/1' R.P.M. U/min	I N. 1 / N. 2	POTENZA KW	G Kg
17,8	11,9	540	810	1,5	10	5,5
15,2	7,6	540	1080	2	10	5,5
16,5	6,6	540	1350	2,5	10	5,5
18	5,5	540	1680	3	10	5,5
18,6	5,8	540	1836	3,5	10	5,5
15,9	4,2	540	2052	3,8	10	5,5