

SERIE: 70000

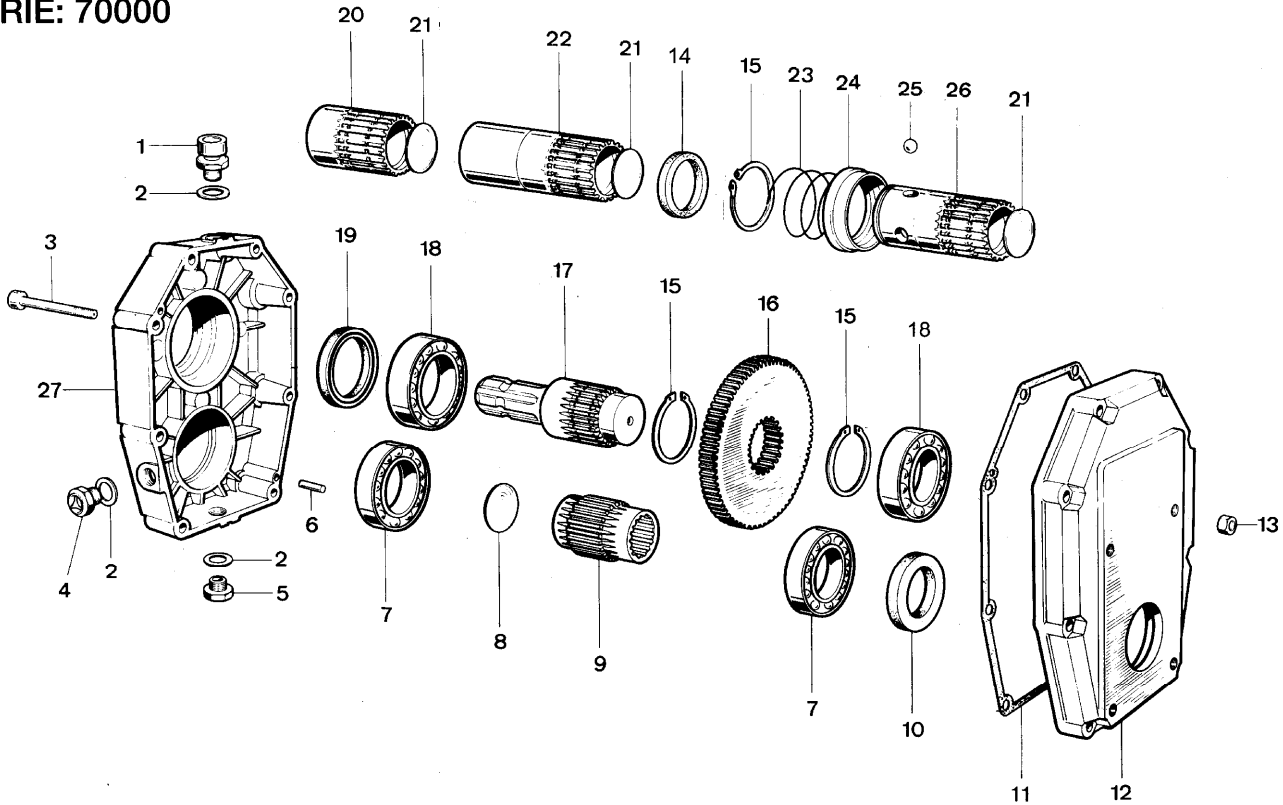

POS.	DENOMINAZIONE	DENOMINATION	DESCRIPTION	BEZEICHNUNG	Q.TÀ
1	Tappo sfiato olio 3/8"	Bouchon reniflard huile 3/8"	Oil breather plug 3/8"	Entlüftungsschraube 3/8"	1
2	Guarnizione	Joint	Gasket	Dichtung	2
3	Vite T.C.E.I. M8x70	Vis T.C.H.C. M8x70	Socket capscrew M8x70	Zylinderkopfschraube mit Innensechskant M8x70	8
4	Tappo livello olio 3/8"	Bouchon niveau huile 3/8"	Oil level plug 3/8"	Ölstandsschraube 3/8"	1
5	Tappo scarico olio 3/8"	Bouchon vidange huile 3/8"	Oil drain plug 3/8"	Ölablaßschraube 3/8"	1
6	Spina	Goupille	Peg	Stift	2
7	Cuscinetto tipo 6009	Palier 6009	Bearing type 6009	Kugellager, Type 6009	2
8	Coperchietto DIN 470 - Ø 37	Petit couvercle DIN 470 D. 37	Cap DIN 470 Ø 37	Deckel DIN 470, Durchm. 37	1
9	Pignone	Pignon	Pinion Gear	Ritzel	1
10	Anello di tenuta Ø 45x65x8	Bague étanchéité 45x65x8	Sealing ring Ø 45x65x8	Dichtring, Durchm. 45x65x8	1
11	Guarnizione	Joint	Gasket	Dichtung	1
12	Coperchio	Couvercle	Cover	Dekel	1
13	Dado M8	Ecrou M8	Nut M8	Mutter M8	8
14	Anello	Bague	Ring	Ring	1
15	Anello seeger Ø 50	Circlip Ø 50	Snap ring dia. 50	Seegerring, Durchm. 50	3
16	Corona	Couronne	Ring gear	Zahnkranz	1
17	Albero presa di forza maschio 1 3/8"	Arbre prise de force mâle 1" 3/8	Male P.T.O. shaft 1" 3/8	Antriebswelle mit Aussenverkeilung 1 3/8"	1
18	Cuscinetto tipo 6010	Palier 6010	Bearing type 6010	Kugellager, Type 6010	2
19	Anello di tenuta Ø 50x65x8	Bague d'étanchéité 50x65x8	Sealing ring Ø 50x65x8	Dichtring, Durchm. 50x65x8	1
20	Albero presa di forza femmina 1 3/8" corto	Arbre prise de force femelle 1" 3/8 court	Female P.T.O. shaft 1" 3/8 short	Antriebswelle mit Innenverkeilung 1 3/8", kurz	1
21	Coperchietto DIN 470 - Ø 40	Petit couvercle DIN 470 D. 40	Cap DIN 470 Ø 40	Deckel DIN 470, Durchm. 40	3
22	Albero presa di forza femmina 1 3/8" lungo	Arbre prise de force femelle 1" 3/8 long	Female P.T.O. shaft 1" 3/8 long	Antriebswelle mit Innenverkeilung 1 3/8", lang	1
23	Molla	Ressort	Spring	Feder	1
24	Anello	Bague	Ring	Ring	1
25	Sfera	Bille	Ball	Kugel	3
26	Albero presa di forza femmina attacco rapido	Arbre prise de force femelle attelage rapide	Female P.T.O. shaft quick fitting	Antriebswelle mit Innenverkeilung, mit Schnellkupplung	1
27	Scatola	Carcasse	Housing	Gehäuse	1

SERIE: 70000

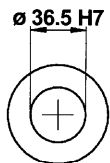

920266

Anello di centraggio pompa Gr. 2

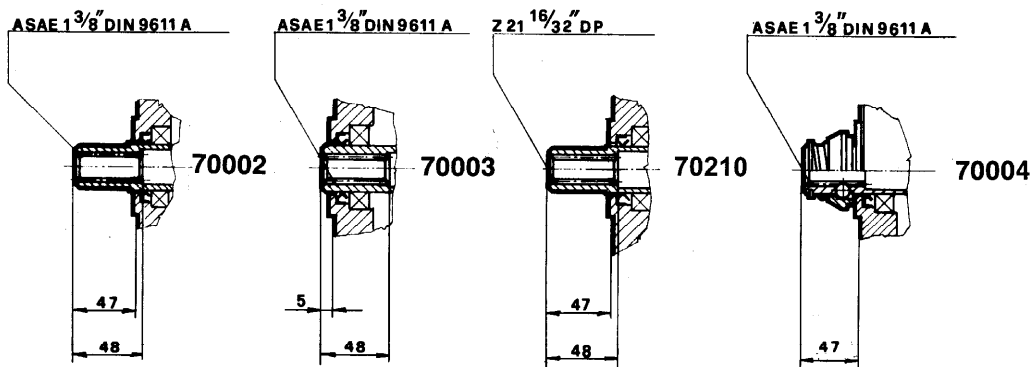
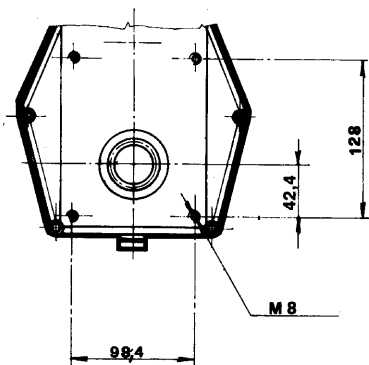
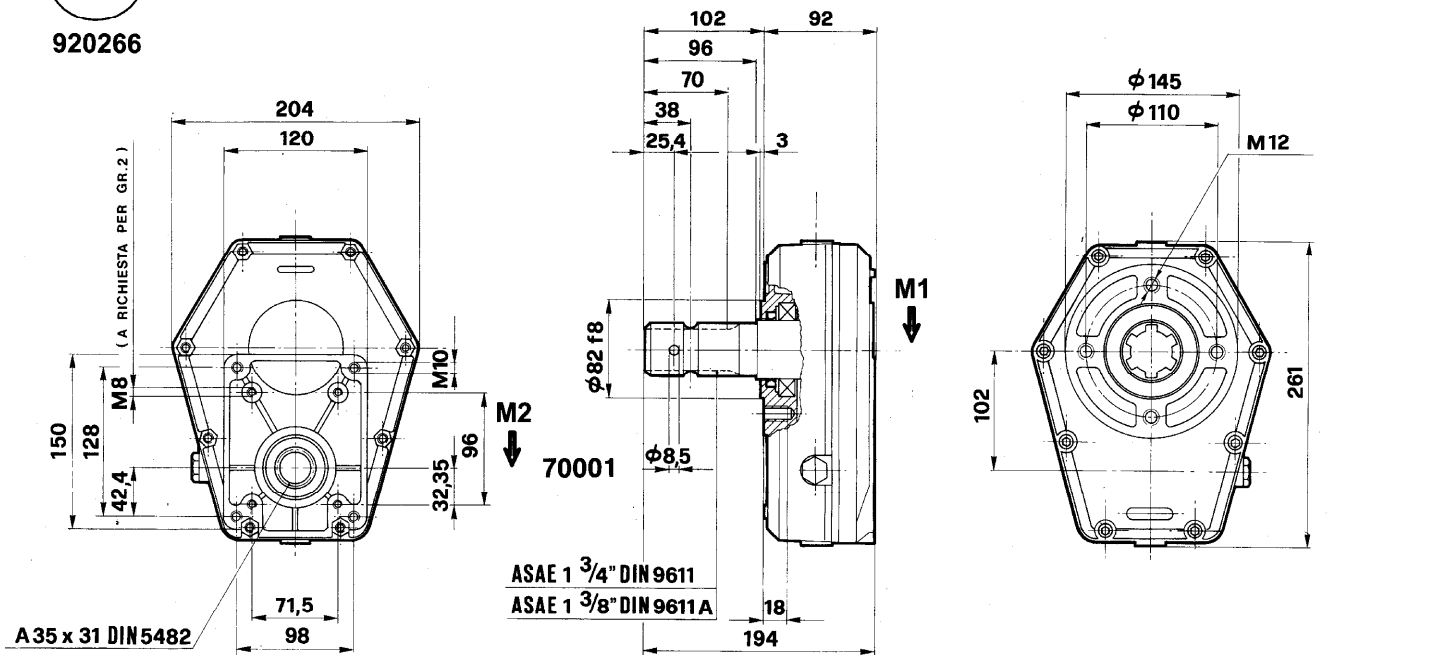

Livello max olio: Lt. 0,350

M1	M2	N. 1 GIRI/1' TOURS/1' R.P.M. U/min	N. 2 GIRI/1' TOURS/1' R.P.M. U/min	I N. 1 / N. 2	POTENZA KW	G Kg
31	31	540	540	1	20	8,1
38	26	540	810	1,5	20	8,1
43	21	540	1080	2	20	8,1
46	18	540	1408	2,5	20	8,1
49	16	540	1620	3	20	8,1
46	13	540	1836	3,5	20	8,1
43,7	11,5	540	2057	3,8	20	8,1

SERIE: 70000

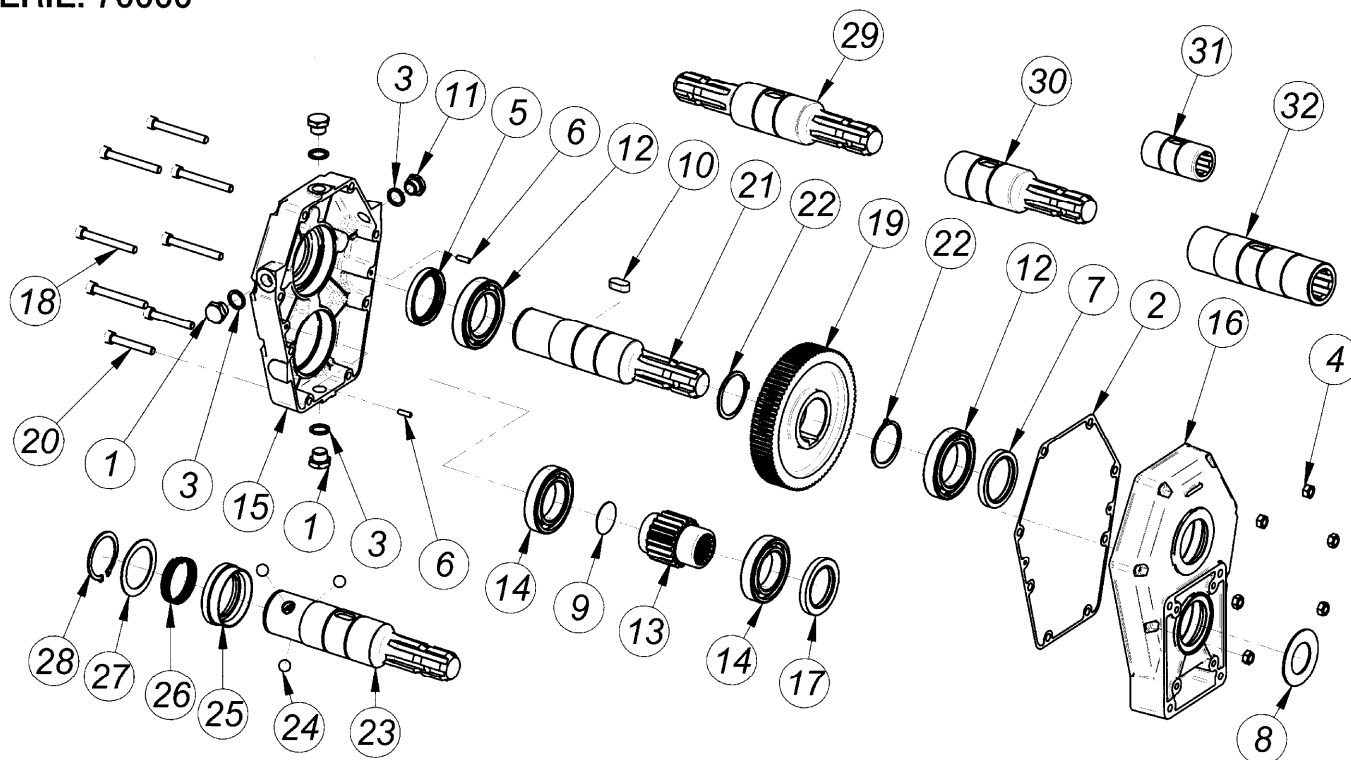

Pos.	DENOMINAZIONE	DENOMINATION	DESCRIPTION	BEZEICHNUNG	Q.TA'
1	Tappo scarico olio 3/8"	Bouchon vindage huile 3/8"	Oil drain plug 3/8"	Ölablafschraube 3/8"	3
2	Guarnizione	Joint	Gasket	Dichtung	1
3	Guarnizione	Joint	Gasket	Dichtung	4
4	Dado M8	Ecrou M8	Nut M8	Mutter M8	6
5	Anello di tenuta 50x65x8	Bague d'ÉtanchÉitÉ 50x65x8	Sealing ring 50x65x8	Dichtring, Durchm. 50x65x8	1
6	Spina UNI 8751 5x16	Goupille UNI 8751 D.5x16	Peg UNI 8751 5x16	Stift durchm UNI 8751 5x16	2
7	Anello di tenuta 50x65x8	Bague d'ÉtanchÉitÉ 50x65x8	Sealing ring 50x65x8	Dichtring, Durchm. 50x65x8	1
8	Anello di centraggio per pompa Gr. 2	Bague de centrage pour pompe Gr. 2	Centering ring for pump group 2	Zentriering für pompe Gr 2	1
9	Coperchietto DIN 470 D.37	Petit couvercle D.37 DIN 470	Cap DIN 470 D.37	Deckel DIN 470, D.37	1
10	Chiavetta 12x25	Clavette 12x25	Key 12x25	Keil 12x25	1
11	Tappo livello olio 3/8"	Bouchon niveau huile 3/8"	Oil drain plug 3/8"	Ölstandschrabe 3/8"	1
12	Cuscinetto tipo 6010	Palier 6010	Bearing 6010	Kugellager Type 6010	2
13	Pignone	Pignon	Pinion gear	Ritzel	1
14	Cuscinetto 6009	Palier 6009	Bearing 6009	Kugellager Type 6009	2
15	Scatola	Carcasse	Housing	Gehäuse	1
16	Coperchio	Couvercle	Cover	Deckel	1
17	Anello di tenuta 45x65x8	Bague d'ÉtanchÉitÉ 45x65x8	Sealing ring 45x65x8	Dichtring, Durchm. 45x65x8	1
18	Vite T.C.E.I. M8x70	Vis T.C.H.C. M8x70	Socket capscrew M8x70	Zylinderkopfschraube mit innensechskant M8x70	6
19	Corona	Couronne	Ring gear	Zahnkranz	1
20	Vite T.C.E.I. M8x55	Vis T.C.H.C M8x55	Socket capscrew M8x55	Zylinderkopfschraube mit Innensechskant M8x55	2
21	Albero presa di forza femmina-maschio 1" 3/8" Z6	Arbre prise de force femelle-Male 1"3/8" Z6	Female-Male P.T.O. shaft 1"3/8" Z6	Antriebsw.m. Innenverkeilung-Aussenverkeilung 1" 3/8" Z6	1
22	Anello seeger d.50	Circlip d.50	Snap ring d.50	Seegerring, Durchm. 50	2
23	Albero presa di forza Femmina-maschio attacco rapido 1" 3/8" Z6	Arbre prise de force Female-Male attelage rapide 1" 3/8" Z6	Female-Male P.T.O. - Quick fitting shaft 1" 3/8" Z6	Antriebsw.m. Innenverkeilung, mit schnellkupplung 1" 3/8" Z6	1
24	Sfera	Bille	Ball	Kugel	3
25	Anello porta molla	Bague porte-ressot	Spring ring	Federhalterung	1
26	Molla	Ressort	Spring	Feder	1
27	Anello	Bague	Ring	Ring	1
28	Anello seeger UNI 7435 - 50	Circlip UNI 7435 - 50	Snap ring UNI 7435 - 50	Seegerring UNI 7435 - 50	1
29	Albero presa di forza maschio-maschio 1" 3/8" Z6	Arbre prise de force Male-Male 1"3/8" Z6	Male-Male P.T.O. shaft 1"3/8" Z6	Antriebsw.m. Aussenverkeilung-Aussenverkeilung 1" 3/8" Z6	1
30	Albero presa di forza femmina-maschio 1" 3/8" Z6 corta	Arbre prise de force femelle-Male 1"3/8" Z6 court	Female-Male P.T.O. shaft 1"3/8" Z6 schort	Antriebsw.m. Innenverkeilung-Aussenverkeilung 1" 3/8" Z6 kurz	1
31	Albero presa di forza femmina corta 1" 3/8" Z6	Arbre prise de force femelle court 1" 3/8" Z6	Female P.T.O. shaft 1"3/8" Z6 schort	Antriebsw.m. Innenverkeilung 1" 3/8" Z6 kurz	1
32	Albero presa di forza femmina 1" 3/8" Z6	Arbre prise de force femelle 1"3/8" Z6	Female P.T.O. shaft 1"3/8" Z6	Antriebsw.m. Innenverkeilung 1" 3/8" Z6	1

SERIE: 70000

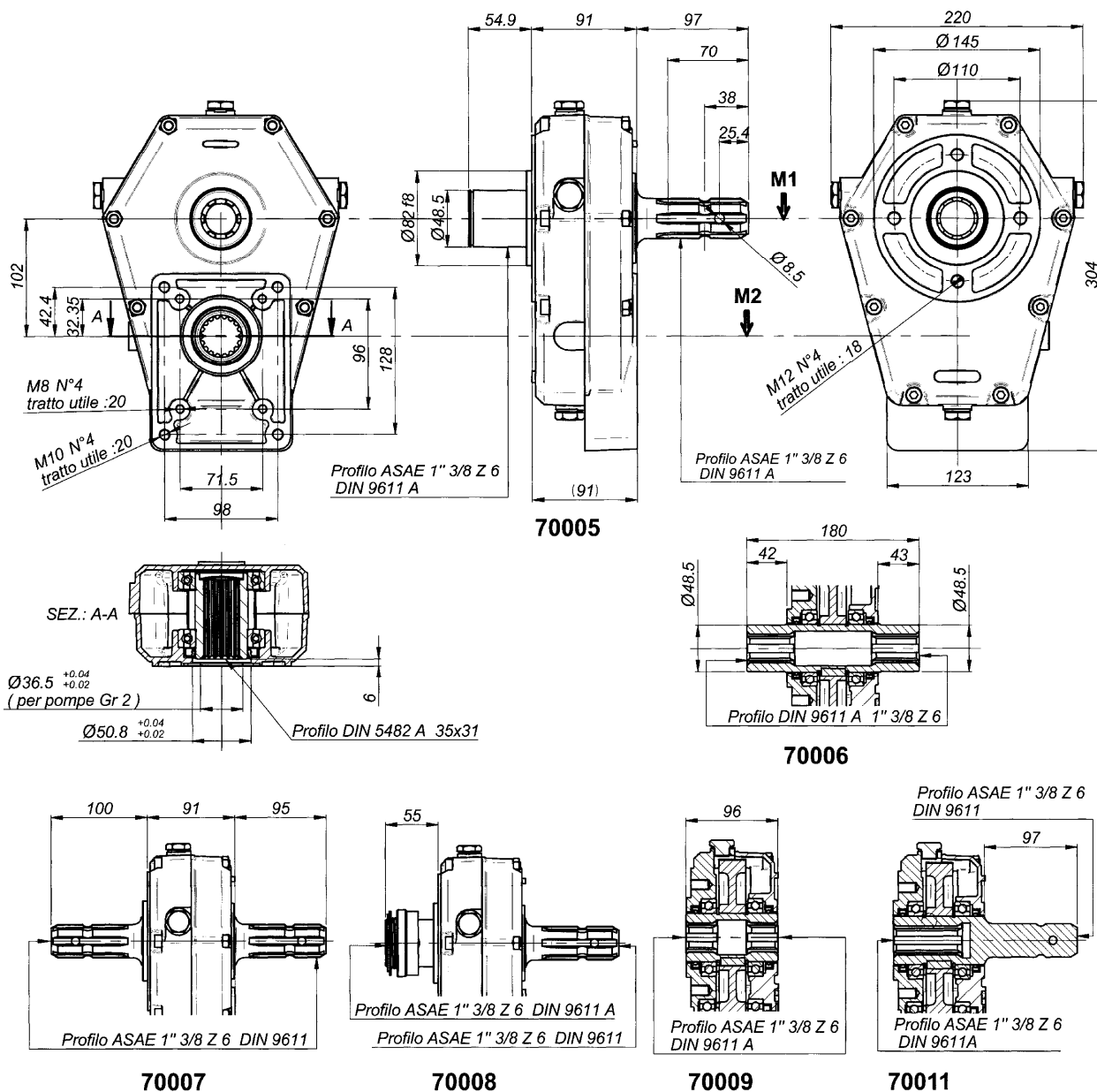

Livello max olio: Lt. 0,350

M1	M2	N. 1 GIRI/1' TOURS/1' R.P.M. U/min	N. 2 GIRI/1' TOURS/1' R.P.M. U/min	I	POTENZA KW	G
daNm	daNm			N. 1 / N. 2		Kg
31	31	540	540	1	20	9,5
38	26	540	810	1,5	20	9,5
43	21	540	1080	2	20	9,5
46	18	540	1408	2,5	20	9,5
49	16	540	1620	3	20	9,5
46	13	540	1836	3,5	20	9,5
43,7	11,5	540	2057	3,8	20	9,5