

POS	QTY	DESCRIPTION	MATERIAL
1	1	TANK BODY	ALUMUNIM 2,5 mm
2	2	SIDE PLATE	ALUMUNIM 2,5 mm
3	2	BRACKET	DC01 QUALITY ST-37 5mm
4	2	BRACKET RUBBER	RUBBER
5	2	BELT	STEEL 2mm
6	2	BELT RUBBER	RUBBER
7	1	FLANGE FILTER SYSTEM	ALM Ø157x10mm
8	1	FLANGE FILLING NECK	ALM Ø105x10mm
9	1	AERATION SUCTION ADAPTER	ALM. 3/4" BSP FEMALE PORT
10	1	LEVEL INDICATOR	
11	1	SUCTION ADAPTER	ALM. 2" BSP FEMALE PORT
12	4	PIN ASSEMBLY	11 SMNPB30 QUALITY AUTOMAT Ø20 STEEL

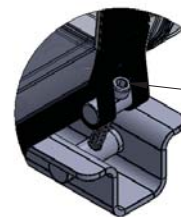
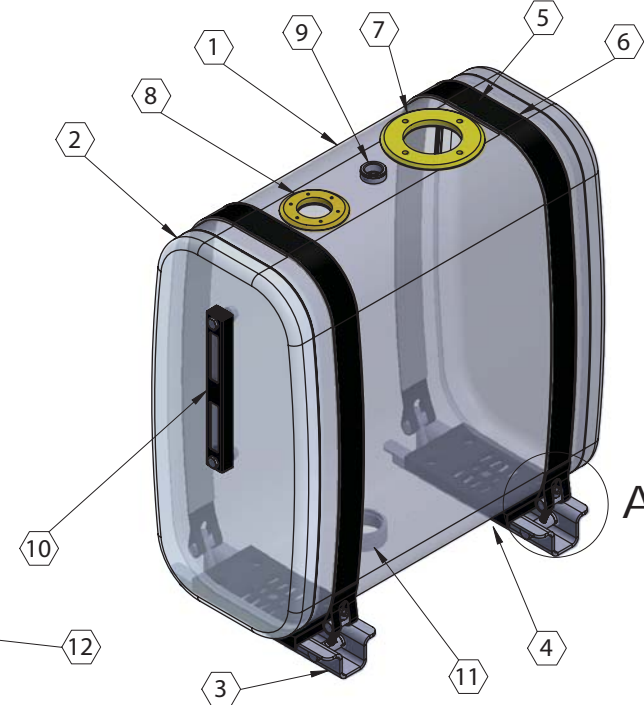

HYDNEX

MSHN120

Alumiinisäiliö 120L