

Dimensions

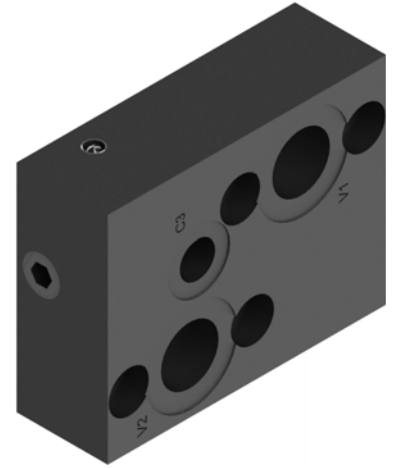

Hydraulic Symbol

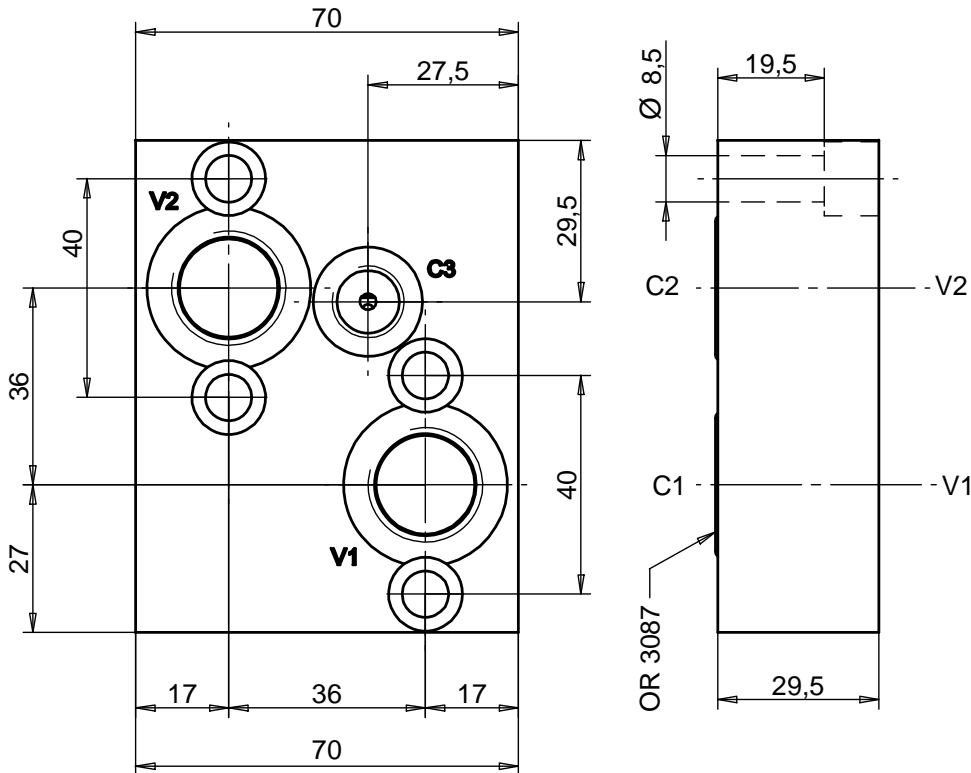
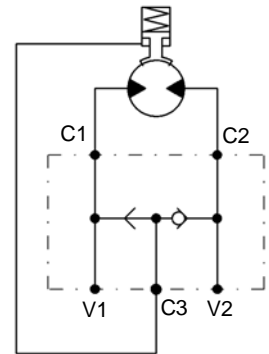

Features

Max Flow	50 lpm
Max Pressure	350 bar
Ports	V1-V2: G 1/2 C3: G 1/4

Materials: Zinc plated steel cartridge, hardened steel inner parts.
Aluminium manifold.

Ordering Code

SHVOMP 03